

▶ PSSu E F PS1(-T)

PILZ

THE SPIRIT OF SAFETY

Operating Manual-21298-EN-08

- Decentralised system PSSuniversal I/O



This document is the original document.

Where unavoidable, for reasons of readability, the masculine form has been selected when formulating this document. We do assure you that all persons are regarded without discrimination and on an equal basis.

All rights to this documentation are reserved by Pilz GmbH & Co. KG. Copies may be made for the user's internal purposes. Suggestions and comments for improving this documentation will be gratefully received.

Pilz®, PIT®, PMI®, PNOZ®, Primo®, PSEN®, PSS®, PVIS®, SafetyBUS p®, SafetyEYE®, SafetyNET p®, the spirit of safety® are registered and protected trademarks of Pilz GmbH & Co. KG in some countries.



SD™ SD means Secure Digital

1	Introduction	5
1.1	Validity of documentation	5
1.1.1	Retaining the documentation	5
1.2	Definition of symbols	5
2	Overview	7
2.1	Module structure	7
2.2	Module features	7
2.3	Front view	8
3	Safety	10
3.1	Intended use	10
3.2	Safety regulations	12
3.2.1	Use of qualified personnel	12
3.2.2	Warranty and liability	12
3.2.3	Disposal	12
4	Function description	13
4.1	Block diagram	13
4.2	Module features	13
4.2.1	Supply voltage	13
4.2.1.1	Current load capacity	14
4.2.2	Integrated protection mechanisms	16
4.3	Configuration	16
4.3.1	Application as a general supply module	16
4.3.2	Addresses in the process image	17
4.3.3	FS error behaviour	17
5	Installation	18
5.1	General installation guidelines	18
5.1.1	Dimensions	18
5.2	Installing the base module	19
5.3	Inserting and removing an electronic module	20
5.3.1	Inserting an electronic module	21
5.3.2	Removing an electronic module	22
5.3.3	Changing an electronic module during operation	22
6	Wiring	23
6.1	General wiring guidelines	23
6.1.1	Mechanical connection of the base modules	23
6.2	Terminal configuration	25
6.3	Connecting the module	28
7	Operation	29
7.1	Messages	29
7.2	Display elements	29
7.2.1	Display elements for module diagnostics	29
7.2.2	Display elements for the status of the module supply and periphery supply	30

7.3	Status byte	31
8	Technical details	32
9	Supplementary data	35
9.1	Permitted operating height	35
10	Order reference	36
10.1	Product	36
10.2	Accessories	36
11	EC declaration of conformity	37
12	UKCA-Declaration of Conformity	38

1 Introduction

1.1 Validity of documentation

This documentation is valid for the products PSSu E F PS1 and PSSu E F PS1-T. It is valid until new documentation is published.

The module PSSu E F PS1-T is suitable for use where there are increased environmental requirements (see [Technical details](#) [ 32]).

This operating manual explains the function and operation, describes the installation and provides guidelines on how to connect the product.

1.1.1 Retaining the documentation

This documentation is intended for instruction and should be retained for future reference.

1.2 Definition of symbols

Information that is particularly important is identified as follows:



DANGER!

This warning must be heeded! It warns of a hazardous situation that poses an immediate threat of serious injury and death and indicates preventive measures that can be taken.



WARNING!

This warning must be heeded! It warns of a hazardous situation that could lead to serious injury and death and indicates preventive measures that can be taken.



CAUTION!

This refers to a hazard that can lead to a less serious or minor injury plus material damage, and also provides information on preventive measures that can be taken.



NOTICE

This describes a situation in which the product or devices could be damaged and also provides information on preventive measures that can be taken. It also highlights areas within the text that are of particular importance.



INFORMATION

This gives advice on applications and provides information on special features.

2 Overview

2.1 Module structure

A module consists of

- ▶ Electronic module and
- ▶ Base module with
 - Screw terminals or
 - Cage clamp terminals

The base modules are the carrier units for the electronic modules and are used to connect the field wiring. The electronic modules are inserted on to the base modules and determine the module's function.

Details of the base modules that can be used are available in the chapter entitled “Intended Use”.

2.2 Module features

The product has the following features:

- ▶ Current load capacity of module supply [max. 2 A
- ▶ When the supply voltage is interrupted, the module supply is buffered for 20 ms.
- ▶ Separate infeed for periphery supply
- ▶ Separate infeed for module supply
- ▶ Infeed for C-rail supply
- ▶ LEDs for:
 - Module supply
 - Periphery supply
 - Module error
- ▶ Application range depends on the base module
- ▶ T-type:
 - PSSu E F PS1-T: for increased environmental requirements

2.3 Front view

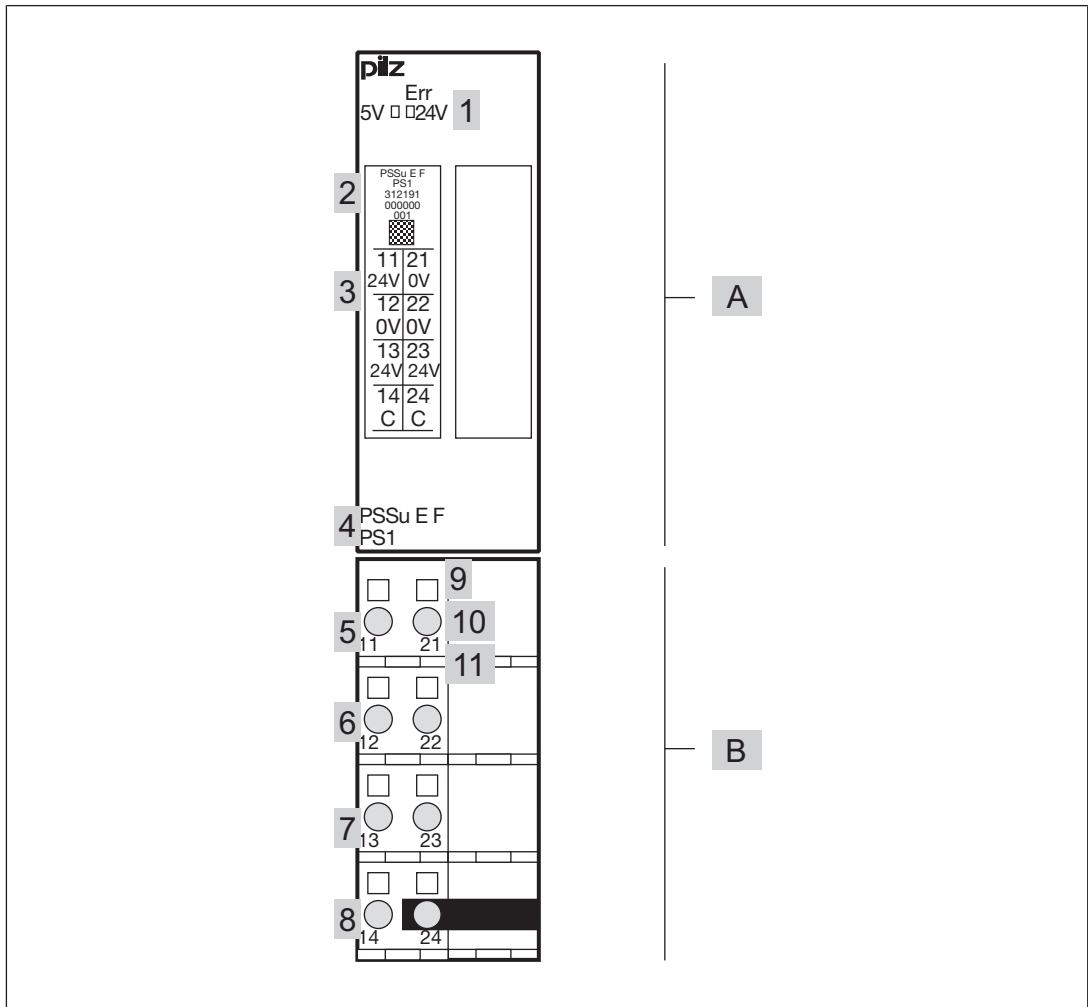

Key:

- ▶ A: Electronic module
- ▶ B: Base module
- ▶ 1: LED for module diagnostics
- ▶ 2: Labelling strip with:
 - Name of electronic module
 - Order number
 - Serial number
 - Hardware version number
 - 2D code
- ▶ 3: Labelling strip for the terminal configuration on the base module
- ▶ 4: Name of electronic module
- ▶ 5: Connection level 1
- ▶ 6: Connection level 2
- ▶ 7: Connection level 3
- ▶ 8: Connection level 4

- ▶ 9: Square mounting holes (connection levels 1, 2, 3 and 4)
 - With screw to loosen/tighten the screw terminal on base modules with screw terminals
 - With mechanism to operate the cage clamp on base modules with cage clamp terminals
- ▶ 10: Round connection holes (connection levels 1, 2, 3 and 4) for connecting the signal lines
- ▶ 11: Mounting slot for colour marker to label the connection level (connection levels 1, 2, 3 and 4)

3 Safety

3.1 Intended use



INFORMATION

If the module name is not explicitly named, the details apply to all the variants of the module.

Use in a PSSu system

The module may be used in a PSSu system in system environment A and B.

The head module establishes in what system environment a PSSu system can be used.

▶ System environment A

A PSSu system in system environment A is a decentralised system PSSu I/O with a field-bus, but without SafetyNET p interface. The automation system PSS 4000 does **not** belong to the system environment A.

▶ System environment

A PSSu system in system environment B is a PSSu system in the h automation system PSS 4000. The PSSu system can belong to one of the following performance classes:

- Decentralised system PSSu I/O (with SafetyNET p)
- Control system PSSu PLC
- Control system PSSu multi

Supply voltage

The module provides the supply for the module supply and periphery supply within the system.

Depending on which base module is used, the module may be used as a:

- ▶ General supply module (first module after a head module, if the head module does not have an integrated supply voltage)
- ▶ Supply module to refresh the module supply and periphery supply
- ▶ Supply module to form supply groups

Particular application areas

▶ Increased environmental requirements

The module PSSu E F PS1-T is suitable for use where there are increased environmental requirements (see [Technical details](#) [ 32]).

Permitted operating height

With reference to the standard IEC 61131-2 the values stated in the technical details for ambient temperature are reduced at heights >2000 m operating height above sea level (see [Supplementary data](#) [ 35]).

EMC-compliant installation

Intended use includes making the electrical installation EMC-compliant. Please refer to the guidelines stated in the "PSSuniversal Installation Manual". The module is intended for use in an industrial environment. Interference may occur if used within a domestic environment.

Improper use

The following is deemed improper use in particular

- ▶ Any component, technical or electrical modification to the module,
- ▶ Use of the module outside the areas described in this operating manual,
- ▶ Any use of the module that is not in accordance with the technical details.

Software tools

The module is supported by:

- ▶ PSSuniversal Configurator and PSSuniversal Assistant from Version 1.4.0
- ▶ PAS4000 from Version 1.0.0



INFORMATION

We recommend that you always use the latest version of the software tool (download from www.pilz.com).

Base modules

The PSSu E F PS1 module may be used in conjunction with the following base modules:

- ▶ PSSu BS 2/8 S
- ▶ PSSu BS-R 2/8 S
- ▶ PSSu BS 2/8 C
- ▶ PSSu BS-R 2/8 C

The module PSSu E F PS1-T may be used in conjunction with the following base modules:

- ▶ PSSu BS 2/8 S-T
- ▶ PSSu BS-R 2/8 S-T
- ▶ PSSu BS 2/8 C-T
- ▶ PSSu BS-R 2/8 C-T

3.2 Safety regulations

3.2.1 Use of qualified personnel

The products may only be assembled, installed, programmed, commissioned, operated, maintained and decommissioned by persons who are competent to do so.

A competent person is a qualified and knowledgeable person who, because of their training, experience and current professional activity, has the specialist knowledge required. In order to inspect, assess and handle products, devices, systems, plant and machinery, this person must be familiar with the state of the art and the applicable national, European and international laws, directives and standards.

It is the company's responsibility only to employ personnel who

- ▶ Are familiar with the basic regulations concerning health and safety / accident prevention,
- ▶ Have read and understood the information provided in the section entitled Safety
- ▶ Have a good knowledge of the generic and specialist standards applicable to the specific application.

3.2.2 Warranty and liability

All claims to warranty and liability will be rendered invalid if

- ▶ The product was used contrary to the purpose for which it is intended,
- ▶ Damage can be attributed to not having followed the guidelines in the manual,
- ▶ Operating personnel are not suitably qualified,
- ▶ Any type of modification has been made (e.g. exchanging components on the PCB boards, soldering work etc.).

3.2.3 Disposal

- ▶ In safety-related applications, please comply with the mission time T_M in the safety-related characteristic data.
- ▶ When decommissioning, please comply with local regulations regarding the disposal of electronic devices (e.g. Electrical and Electronic Equipment Act).

4 Function description

4.1 Block diagram

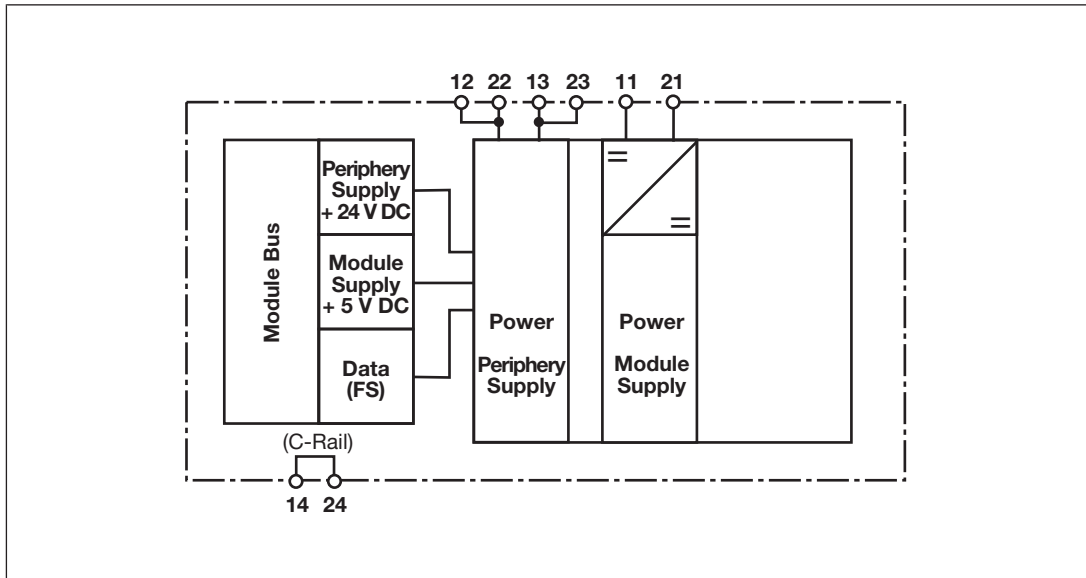

4.2 Module features

4.2.1 Supply voltage

The product provides the module supply and periphery supply for the modules on the module bus:

- ▶ Module supply
 - Supply voltage for subsequent module (right-hand side)
- ▶ Periphery supply
 - Supply voltage for sensors, actuators and test pulses
- ▶ C-rail

Infeed of the permitted additional supplies for the C-rail; a detailed description of how to use the C-rail can be found in the system description.

When the supply voltage is fed in separately, the module supply and periphery supply are galvanically isolated. If galvanic isolation is not required, a common power supply may be used for the periphery supply and module supply.

The module enables

- ▶ The module supply and periphery supply to be refreshed:
 - The relevant base module interrupts the connection to the incoming (left-hand) module supply, periphery supply and C-rail on the module bus. The 0 V supply on the module supply is connected to the left and right.
- ▶ Supply groups to be formed
 - The relevant base module interrupts the connection to the incoming (left-hand) periphery supply and C-rail on the module bus. Each supply group requires its own supply module.

4.2.1.1 Current load capacity

Ensure you comply with the current load capacity of the module and periphery supply (see "Technical Details"). If the current load is higher, an additional supply voltage module is required to refresh the module supply and periphery supply.

► **Module supply**

The current load is the total current consumption of all the electronic and compact modules.

The module supply does not automatically switch off if values exceed or drop below their limits. However, the "5 V" LED will light and a message will be entered in the error stack or diagnostic log.

► **Periphery supply**

The current load is the total current consumption of the sensors, actuators and test pulses supplied via the input/output modules.

The periphery supply does not automatically switch off if values exceed or drop below their limits. However, the "24 V" LED will light and a message will be entered in the error stack or diagnostic log.

Please refer to the derating diagram.

► **C-rail**

If the current load is higher, the C-rail must use a different supply to prevent overload.

Please refer to the derating diagram.

PSSu E F PS1: Derating diagram for periphery supply and C-rail: Temperature T dependent on load current I

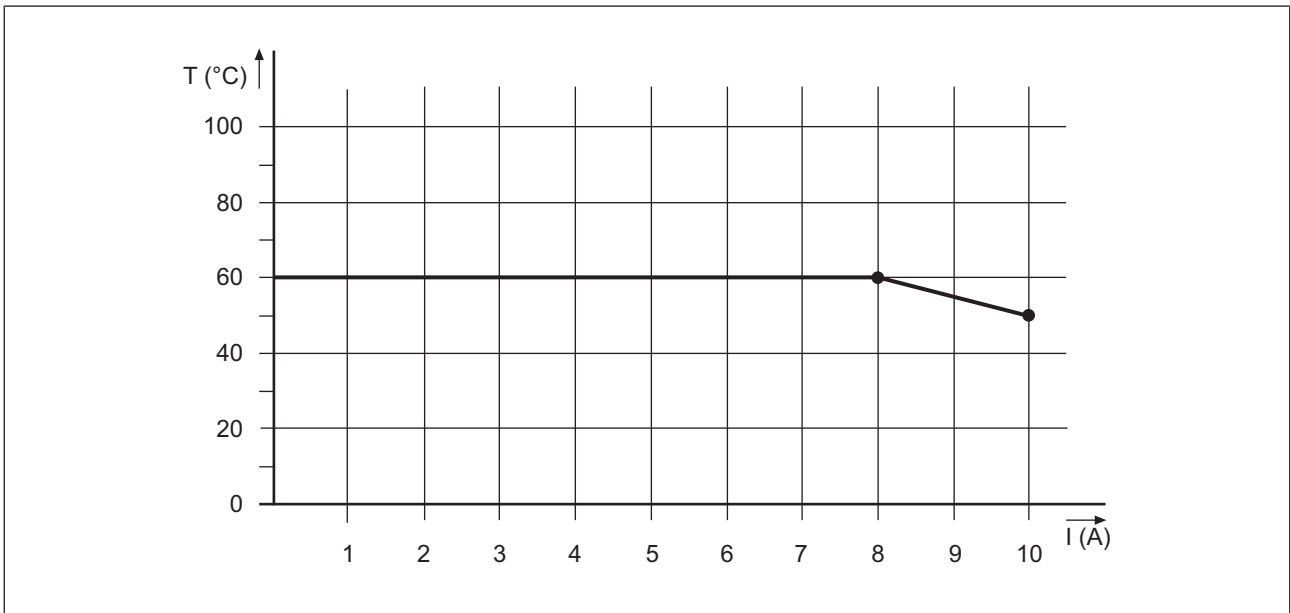

PSSu E F PS1-T: Derating diagram for infeed for periphery supply: Permitted ambient temperature T dependent on load current I



PSSu E F PS1-T: Derating diagram for infeed for module supply: Permitted ambient temperature T dependent on load current I

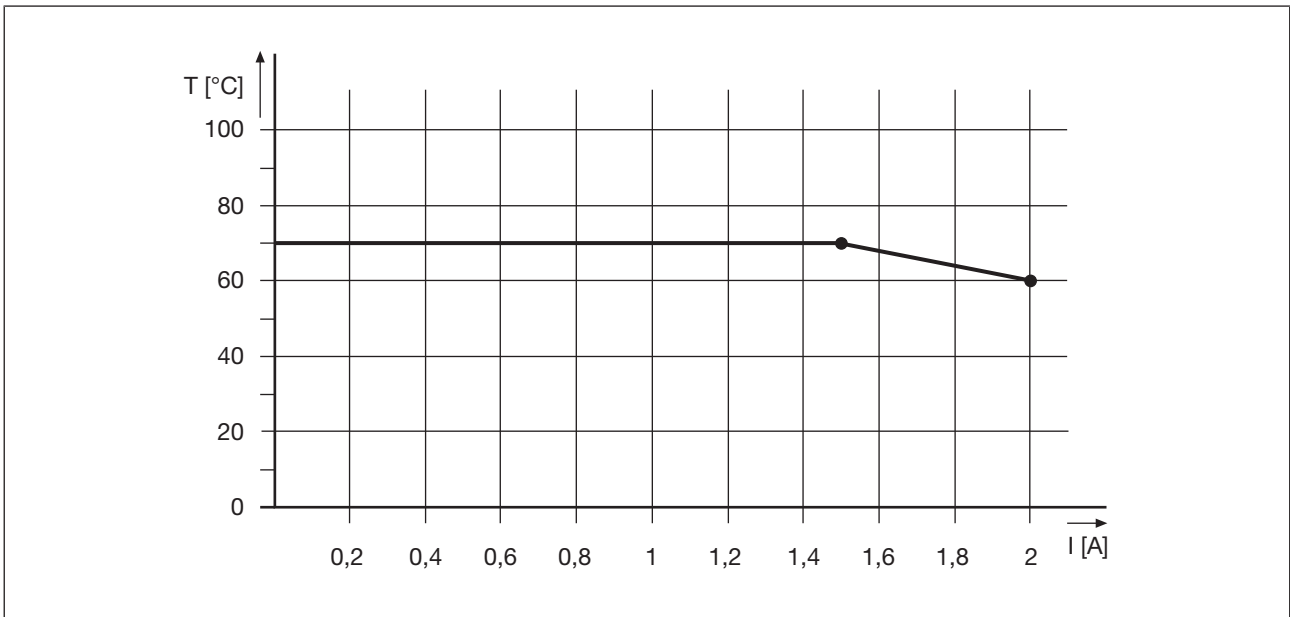

4.2.2 Integrated protection mechanisms

The module has the following protection mechanisms:

- ▶ Infeed for module supply
 - Polarity protection
 - Voltage monitoring
 - Transient voltage limitation
- ▶ Module supply
 - Short circuit-proof
- ▶ Periphery supply
 - Voltage monitoring (exceeding upper/lower limit)

The module registers the following errors:

- ▶ Start-up error
- ▶ Configuration error
- ▶ FS communication error
- ▶ Bus termination error
- ▶ Temperature error: too warm
- ▶ Overvoltage error
- ▶ Undervoltage error
- ▶ Error in the overvoltage protection diodes

4.3 Configuration

4.3.1 Application as a general supply module

The module can provide a standard bus system with various status information. To do this, the general supply voltage module (the first module after the head module) must be configured for read access. The configuration is made in the PSSUniversal Configurator in the PSS WIN-PRO system software:

- ▶ Read access through the standard bus system:
 - “R” configuration

Further information on configuration is available in the PSSUniversal Configurator's online help.

4.3.2 Addresses in the process image

If read access is configured, the module occupies 8 consecutive bit addresses in the ST-PII process image. The first supply module after the head module on slot 0 supplies status information about the PSSu system.

Configuration	SafetyBUS p	Standard bus system	
	FS-PIO	ST-PII	ST-PIO
None	---	---	---
Read ST ("R")		8 Bit	---



INFORMATION

Further information on the structure and contents of the status byte can be found under "Operation".

4.3.3 FS error behaviour

In the case of a safety-related error on an FS output, all FS outputs in the affected I/O-Group (SafetyBUS p) are shut down.

In the case of a safety-related error on an FS input, the process image of all FS inputs in the affected I/O-Group (SafetyBUS p) is set to zero.

The I/O-Group switches to a STOP condition. An error telegram is then triggered on Safety-BUS p and the error is entered in the PSSuniversal error stack.

5 Installation

5.1 General installation guidelines

Please refer also to the PSSuniversal Installation Manual.



NOTICE

Damage due to electrostatic discharge!

Electrostatic discharge can damage components. Ensure against discharge before touching the product, e.g. by touching an earthed, conductive surface or by wearing an earthed armband.

5.1.1 Dimensions

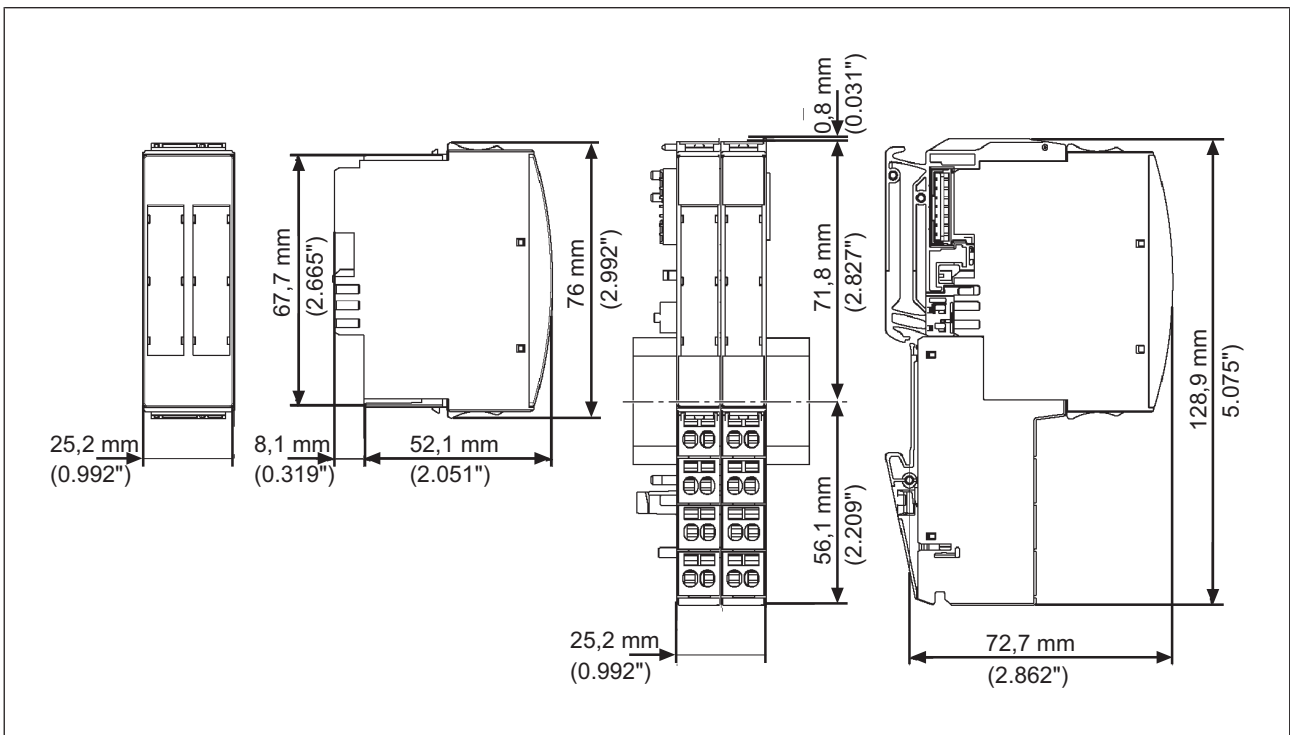

5.2 Installing the base module

Prerequisite:

- ▶ The head module must be installed.
- ▶ If the head module does not have an integrated power supply, a supply voltage module must be installed to the right of the head module.

Please note:

- ▶ For mechanical reasons it is not possible to mix base modules with screw terminals and base modules with cage clamp terminals.
- ▶ All contacts should be protected from contamination.
- ▶ The mechanics of the base modules are designed for 50 plug in/out cycles.

Procedure:

- ▶ We recommend that you wire up the base modules before inserting the electronic modules.
- ▶ Slot the groove on the base module on to the mounting rail from below [1].
- ▶ Push the base module back [2] until you hear it lock into position.
- ▶ On the mounting rail, slide the base module to the left until you hear the two lateral mounting hooks on the adjacent module lock into position [3].

Schematic representation:

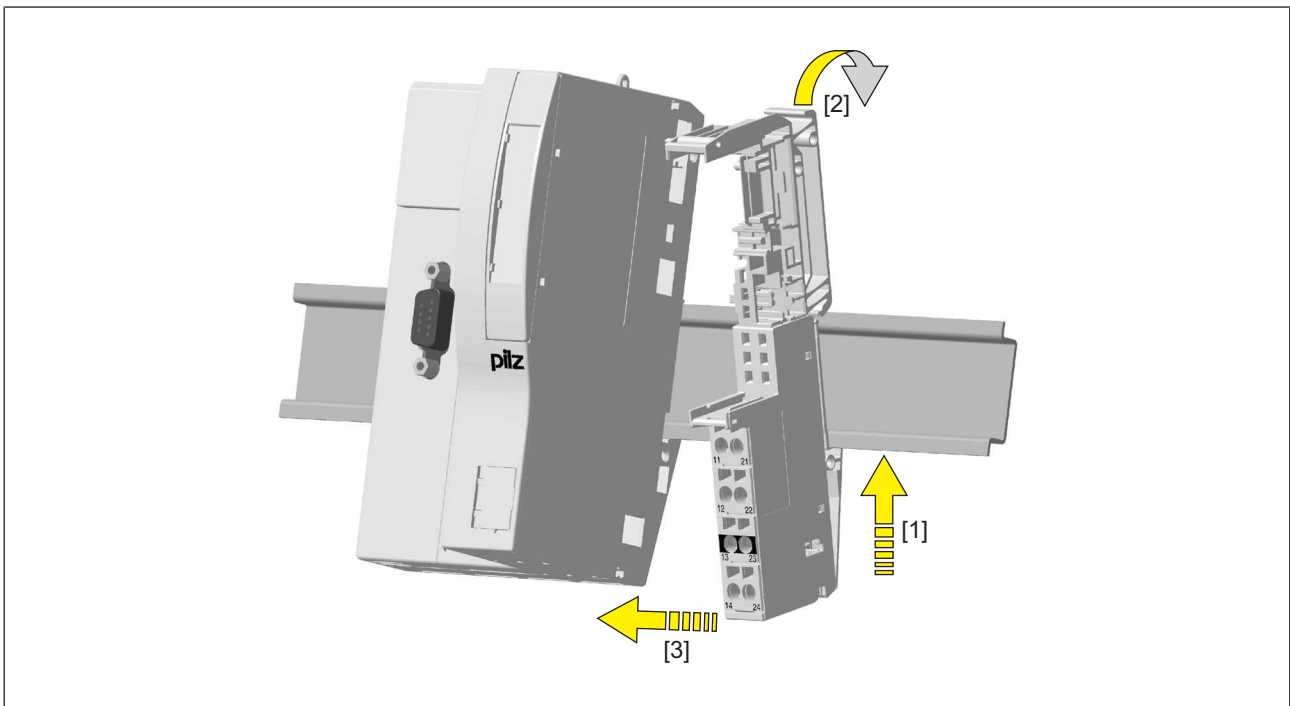

5.3 Inserting and removing an electronic module

Please note:

- ▶ Only insert on to base modules that are already installed.
- ▶ Preferably these base modules should be ready wired.
- ▶ Electronic modules with outputs may only be inserted and removed when the load is switched off. Unforeseeable error reactions may be triggered if modules are inserted and removed under load.
- ▶ When an electronic module is plugged into a base module for the first time, one part of the coding element remains on the electronic module, while its counterpart is fixed on to the base module. This is how the base module is coded.
- ▶ The mechanics of the electronic modules are designed for 50 plug in/out cycles.

5.3.1 Inserting an electronic module

Procedure:

- ▶ The electronic module must audibly lock into position [1].
- ▶ Mark the electronic module using the labelling strips [2].

Schematic representation:

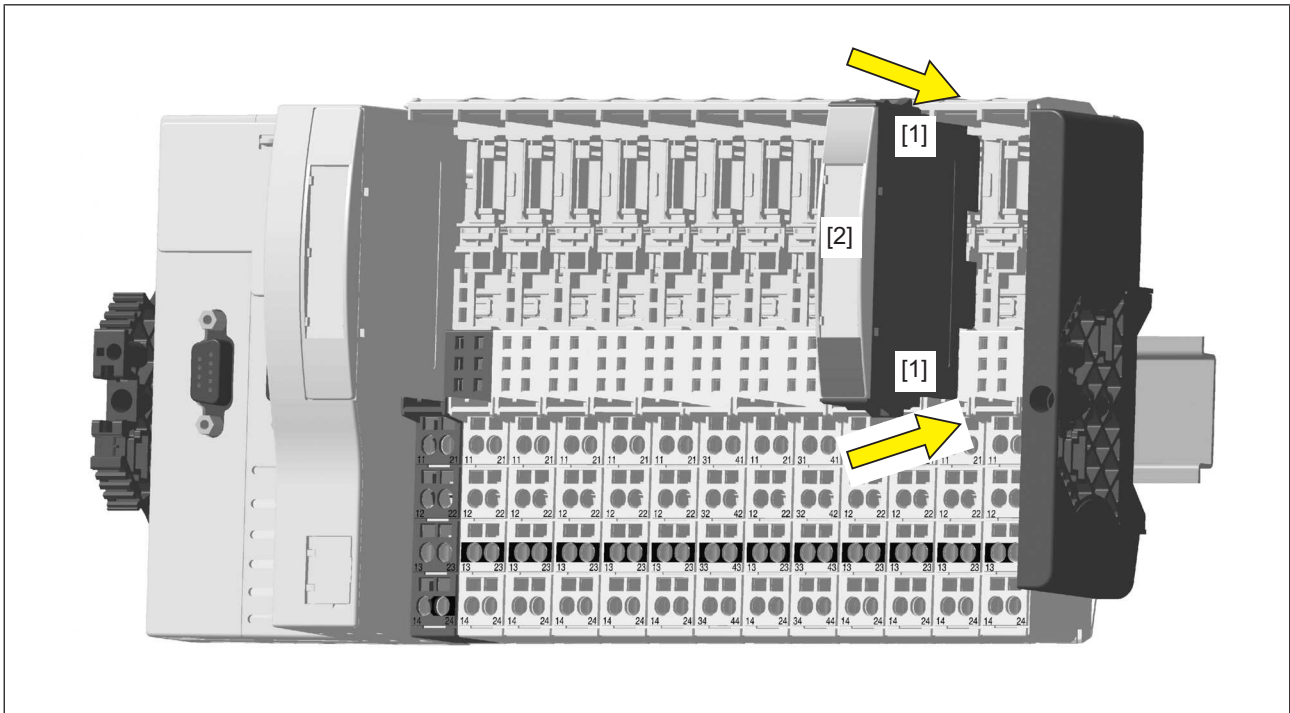

5.3.2 Removing an electronic module

Procedure:

- ▶ Press the locking mechanisms [1] together simultaneously.
- ▶ Pull out the electronic module [2].

Schematic representation:

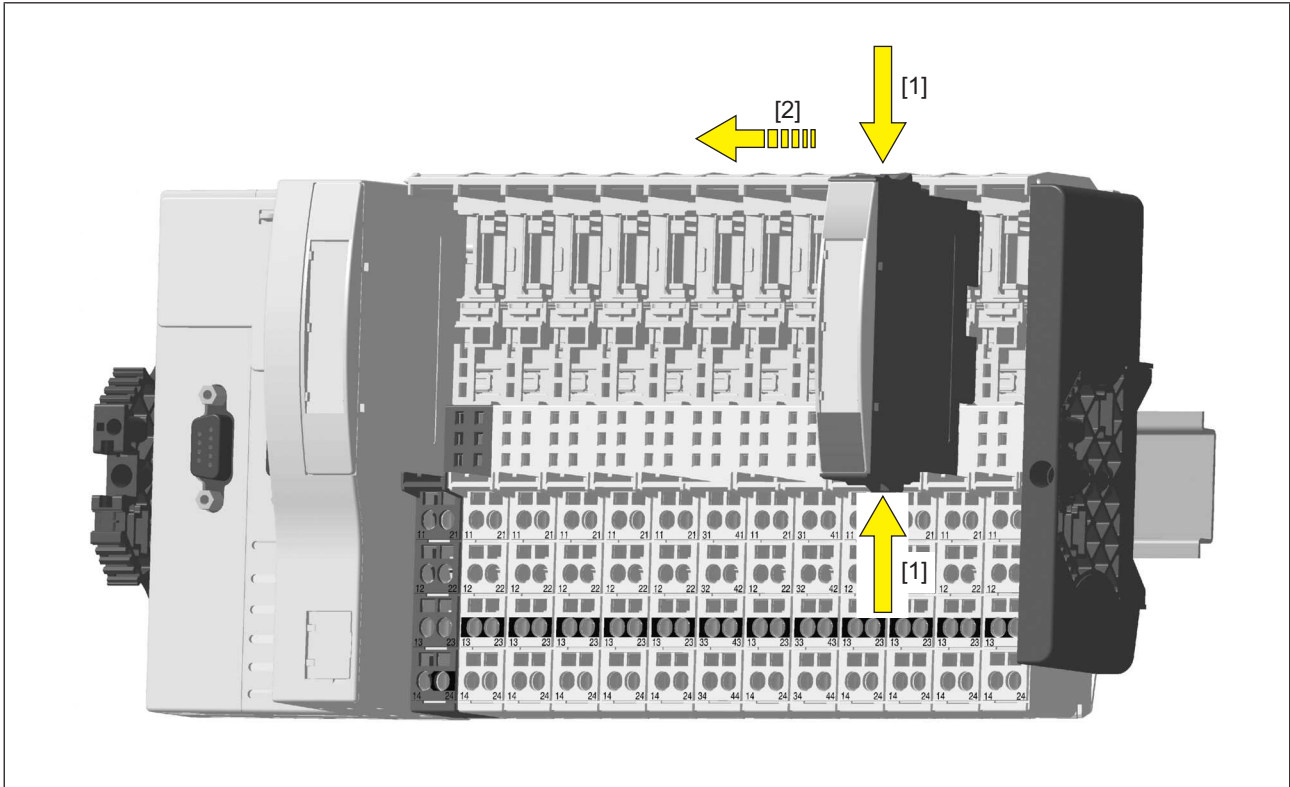

5.3.3 Changing an electronic module during operation

It is possible to change an electronic module during operation. The configuration data is retained when a module is changed.

Effects:

- ▶ System environment A:
 - In the event of a potential FS communication error, the FS section of the PSSu system and all relevant I/O-Groups (SafetyBUS p) switch to a STOP condition.
- ▶ System environment B:
 - All FS hardware outputs on the PSSu system switch to a safe condition.
 - The substitute values are used for the modules' FS outputs, with Valid Bits = FALSE.



CAUTION!

Sparking can cause interference and errors!

Only change the module when the load is switched off!

6 Wiring

6.1 General wiring guidelines

Please note:

- ▶ The requirements for the supply voltages can be found in the chapter entitled [Technical details](#) [32].
- ▶ Protective separation must be ensured for the external power supplies that generate the supply voltages. Failure to do so could result in electric shock.
- ▶ The external power supplies for generating the supply voltages (periphery supply and module supply) must meet the regulations for extra low voltages with protective electrical separation (SELV, PELV). Failure to do so could result in electric shock. A device with a basic insulation that has a supply voltage of over 50 VAC or 120 VDC must not be connected in parallel to the module supply.
- ▶ The external power supplies must comply with the current applicable standard EN 62368-1 or EN 61010-2-201.
- ▶ The maximum current load for the periphery supply on the module bus is 10 A. Please refer to the derating diagram in the chapter entitled "Function Description".
- ▶ Earth the 0 V supply on the periphery supply or monitor each supply group for earth faults.
- ▶ The connection of the 0 V supply to the central earth bar or earth fault monitor must be in accordance with relevant national regulations (e.g. EN 60204-1, NFPA 79:17-7, NEC: Article 250).
- ▶ Details of the minimum range for cable cross sections on connection terminals can be found under [Technical details](#) [32].
- ▶ Use copper wiring.

6.1.1 Mechanical connection of the base modules

Procedure:

- ▶ Use a flat blade screwdriver (DIN 5264-A)!

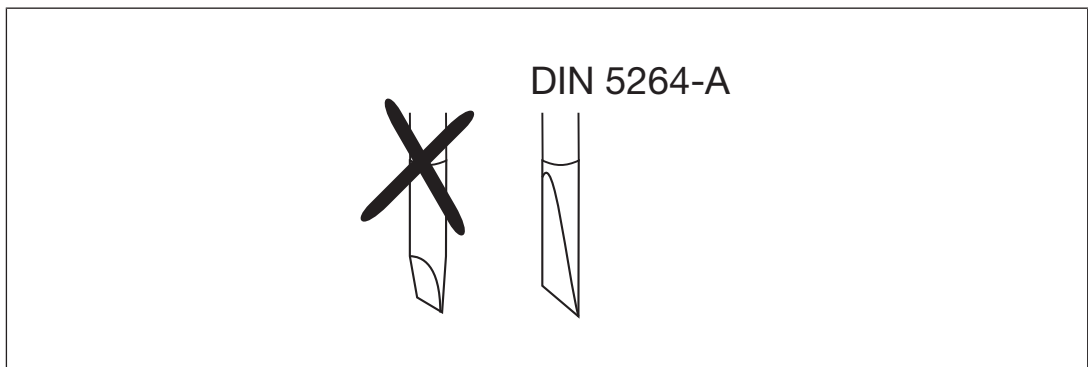

- ▶ Strip the wire back 8 mm.
- ▶ If necessary, label the connection level with a colour marker [3].

- ▶ Base module with screw terminals:
 - Use a screwdriver to loosen the screw on the screw terminal [1]
 - Insert the stripped cable into the round fixing hole [2], as far as it will go.
 - Tighten up the screw on the screw terminal.
 - Check that the cable is firmly seated.
- ▶ Base module with cage clamp terminals:
 - Insert the screwdriver [4] into the square hole [1].
 - Insert the stripped cable into the round fixing hole [2], as far as it will go [5].
 - Pull out the screwdriver [6].
 - Check that the cable is firmly seated.

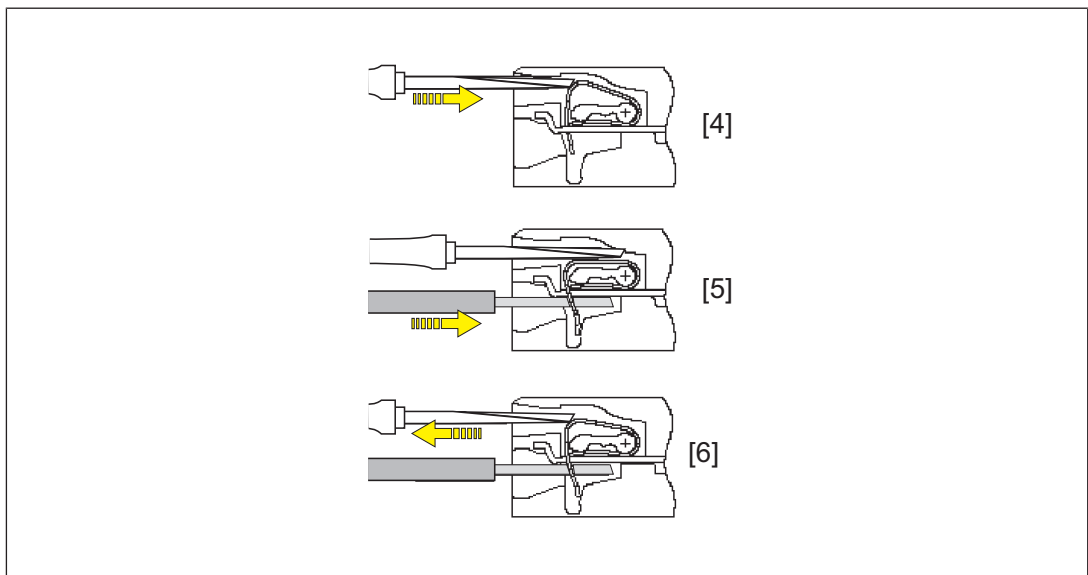
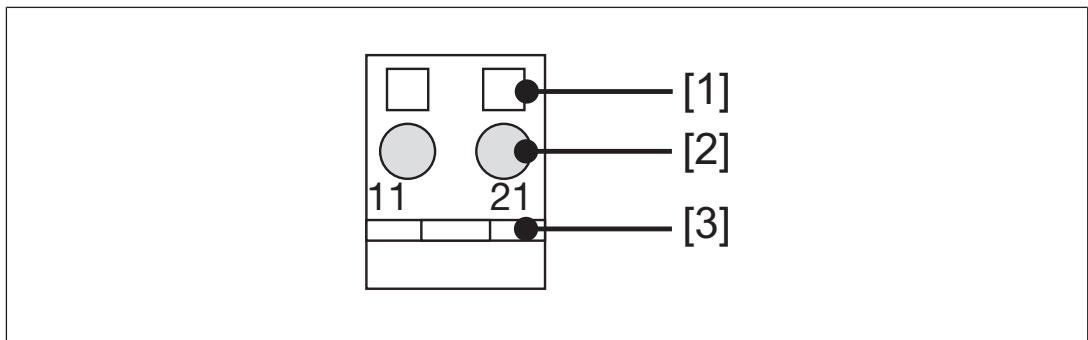

Please note:

- ▶ The minimum cable cross section for field connection terminals on the base modules is 0.14 mm² (AWG26).
- ▶ The maximum cable cross section for field connection terminals is:
 - Digital inputs: 1.5 mm² (AWG16)
 - Digital outputs: 2.0 mm² (AWG14)
 - Inputs/outputs on the counter modules: 1.5 mm² (AWG16)
 - Analogue inputs/outputs: 1.5 mm² (AWG16)

- Communication cables: 1.5 mm² (AWG16)
- Test pulse outputs: 1.5 mm² (AWG16)
- Power supply: 2.5 mm² (AWG12)
- Functional earth: 2.5 mm² (AWG12)
- ▶ On base modules with screw terminals:
 - If you use a multi-strand cable to connect the I/Os, it is recommended that you use ferrules conforming to Parts 1 and 2 of DIN 46228, 0.14 ... 1.5 mm², Form A or C, although this is not essential. To crimp the ferrules you can use crimp pliers (crimp form A or C) conforming to EN 60947-1, such as the PZ 1.5 or PZ 6.5 from Weidmüller, for example.
 - Maximum torque setting: 0.8 Nm
- ▶ Use copper wiring.

6.2 Terminal configuration

- ▶ For use as a general supply module, supplying the head module and subsequent modules

Base module	Terminal configuration	
Screw terminals: PSSu BS 2/8 S PSSu BS 2/8 S-T	11: +24 V infeed for module supply	
Cage clamp terminals: PSSu BS 2/8 C PSSu BS 2/8 C-T	21: 0 V infeed for module supply	
	12 -22: 0 V periphery supply, interrupted to the left (12-22 linked within the base module)	
	13 -23: +24 V periphery supply, interrupted to the left (13-23 linked within the base module)	
	14-24 C-rail supply, interrupted to the left (14-24 linked within the base module)	

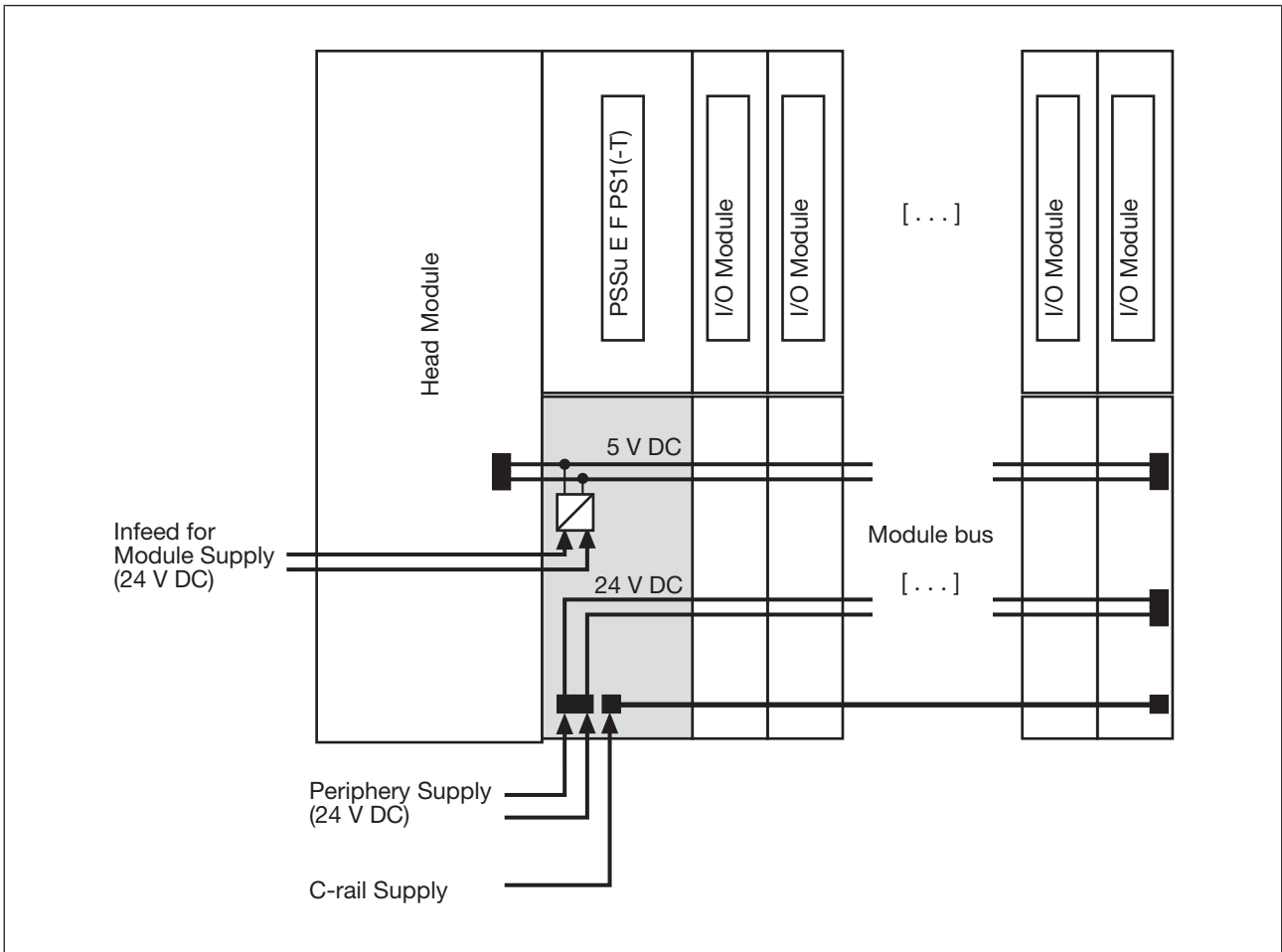

- ▶ For use as a supply module to refresh the module supply and periphery supply
- ▶ For use as a supply module to form supply groups
 - To interrupt the incoming periphery supply and C-rail
 - To provide subsequent modules with the module supply, periphery supply and C-rail supply
- ▶ With these base modules the supply module cannot be used as the first module after the head module.

Base module	Terminal configuration	
Screw terminals: PSSu BS-R 2/8 S PSSu BS-R 2/8 S-T	11: +24 V infeed for module supply, interrupted to the left	
Cage clamp terminals: PSSu BS-R 2/8 C PSSu BS-R 2/8 C-T	21: 0 V infeed for module supply	
	12 -22: 0 V periphery supply, interrupted to the left (12-22 linked within the base module)	
	13 -23: +24 V periphery supply, interrupted to the left (13-23 linked within the base module)	
	14-24 C-rail supply, interrupted to the left (14-24 linked within the base module)	

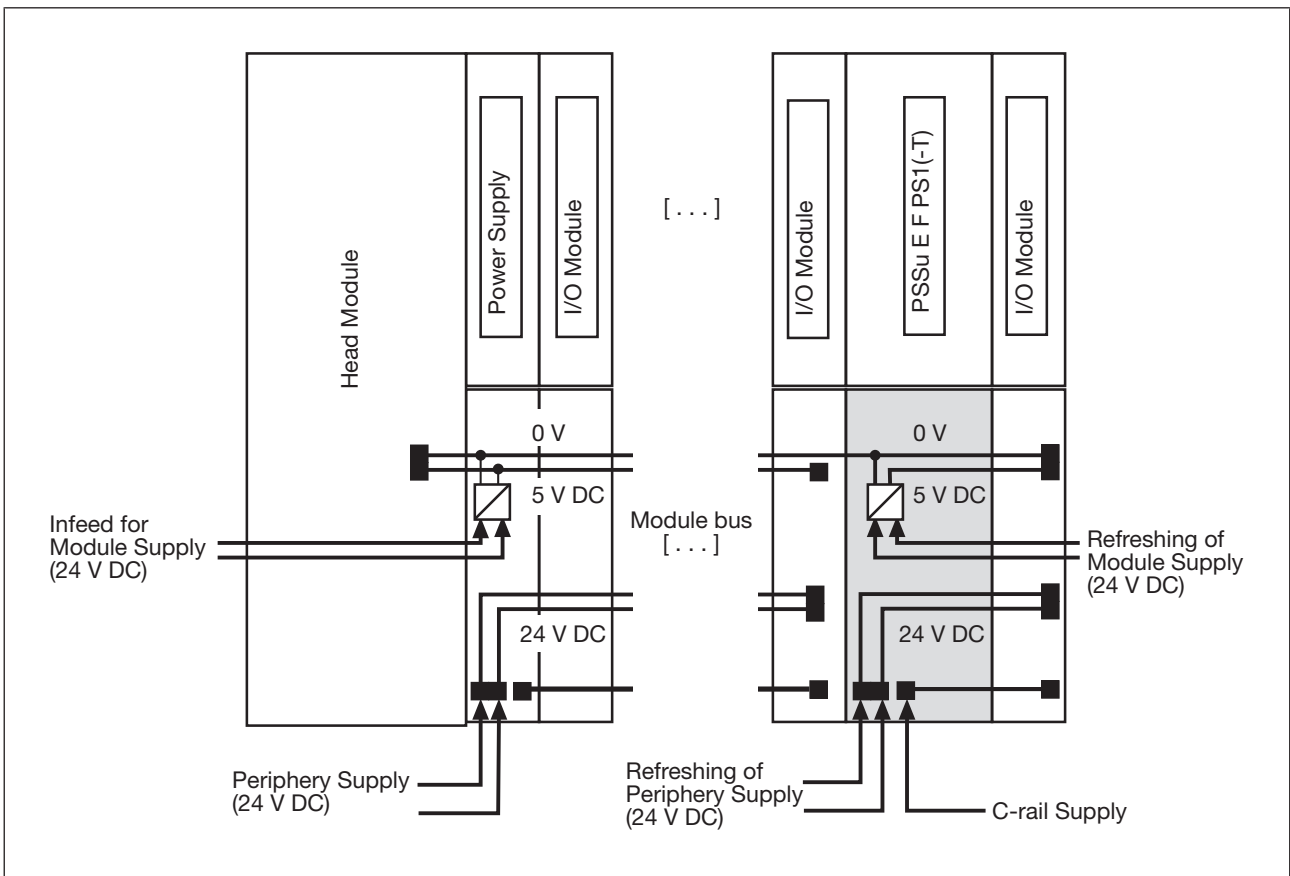

6.3 Connecting the module

Separate power supplies for module supply and periphery supply

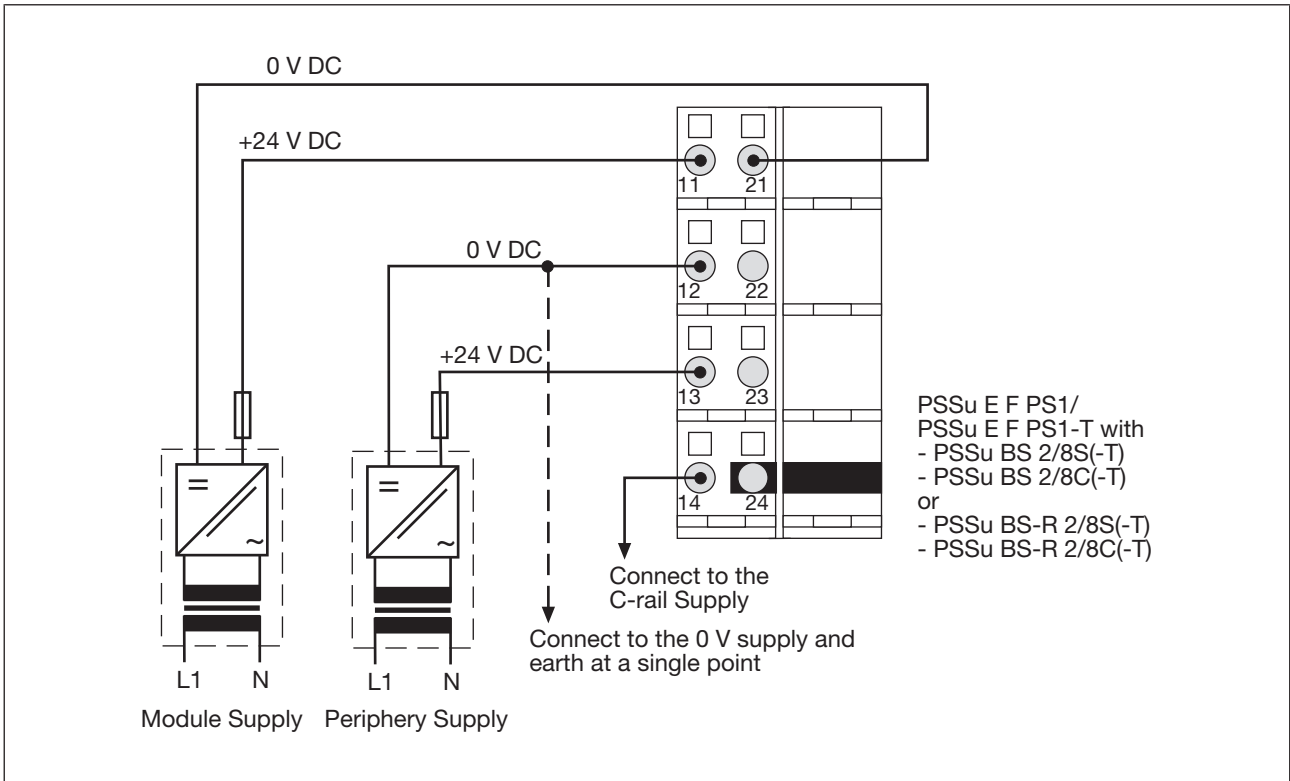

Common power supply for module supply and periphery supply

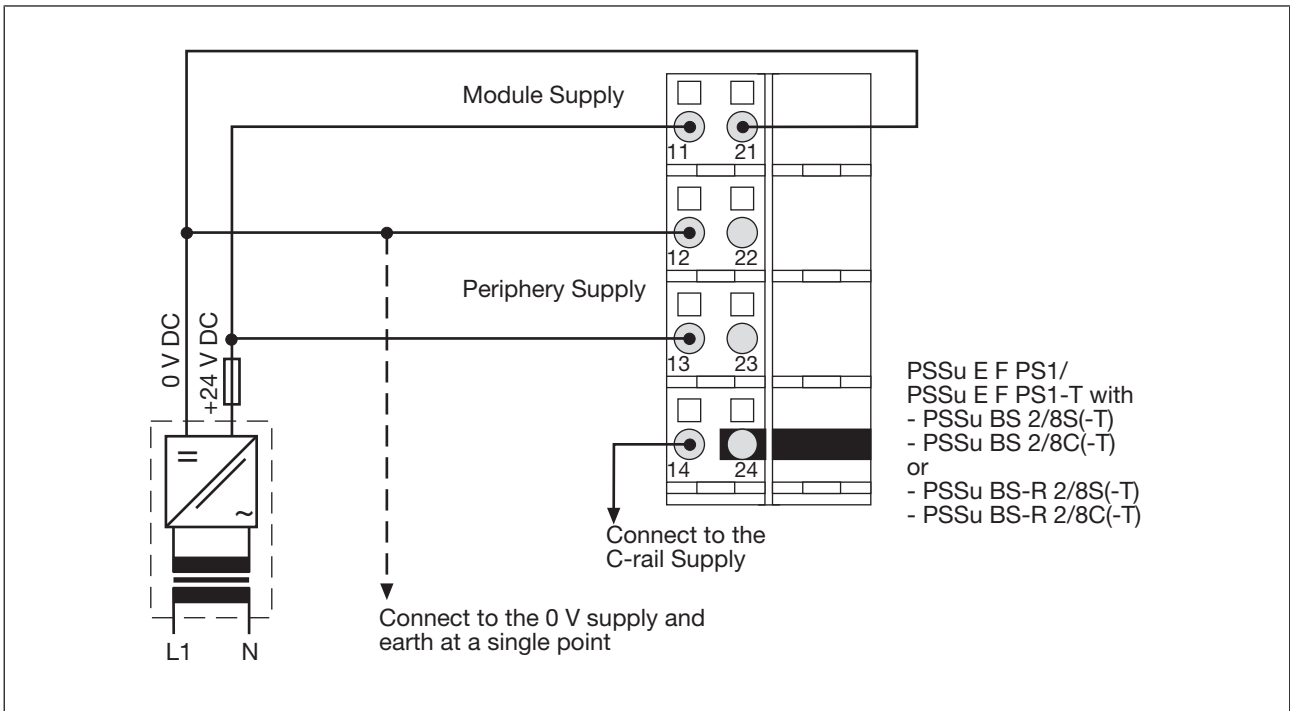

7 Operation

7.1 Messages

A module error is displayed via the “Err” LED (see section entitled “Display elements”), signalled to the head module and then entered in the head module's error stack or diagnostic log.



The module can detect the following errors:

Module error	Explanation	Remedy
Start-up error	Error as the PSSu system starts up	Change faulty module.
Configuration error	Incorrect module type configured.	The configured hardware registry does not match the actual hardware registry.
FS communication error	Error during FS communication	Change faulty module.
Temperature error: too warm	Ambient temperature too high: Entry in the error stack or diagnostic log	Ensure there is sufficient ventilation in the control cabinet or prevent overload.
Overvoltage error	A system voltage or infeed is too high.	Stabilise the supply or change the faulty supply voltage module.
Undervoltage error	A system voltage or infeed is too low.	Stabilise the supply or change the faulty supply voltage module.
Error in the overvoltage protection diodes	Overvoltage protection diodes are defective.	Change faulty supply voltage module.

Further information on PSSu error messages is available in the online help for PSS WIN-PRO or PAS4000.



7.2 Display elements

Legend

-  LED on
-  LED flashes
-  LED off

7.2.1 Display elements for module diagnostics

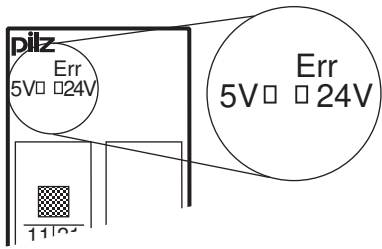
The module has an LED for displaying module errors (“Err” LED).

	LED			Meaning
	Designation	Colour	Status	
Err	---		●	No error
	Red			Module error

7.2.2 Display elements for the status of the module supply and periphery supply

A status LED is assigned to both the module supply and periphery supply ("5 V" and "24 V" LEDs).

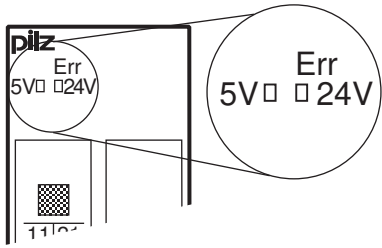
	LED			Key
	Description	Colour	Status	
5 V	---		●	No supply voltage or error in the supply voltage for module supply
	Green		☀	Error-free supply voltage for module supply
24 V	---		●	Error in the supply voltage for periphery supply
	Red		●☀	No supply voltage for periphery supply
	Green		☀	Supply voltage for periphery supply is error-free

7.3 Status byte

The first supply module after the head module can communicate a variety of status information to the ST-PII (see table below). The information is transmitted using the module's status byte. Read access (R) is configured for that purpose.

Structure and contents of the status byte

Bit number	Signal	Key
0	0	SafetyBUS p in a STOP condition
	1	SafetyBUS p in a RUN condition
1	0	The PSSu section configured for the FS inputs (section A or B) is in a STOP condition.
	1	The PSSu section configured for the FS inputs (section A or B) is in a RUN condition.
2	0	The PSSu section configured for the FS outputs (section A) is in a STOP condition.
	1	The PSSu section configured for the FS outputs (section A) is in a RUN condition.
3	0	No general error in the PSSu FS section
	1	General error in the PSSu FS section
4	0	No general error in the PSSu ST section
	1	General error in the PSSu ST section
5	0	No error on the FS modules
	1	At least one FS module is registering an error
6	0	No error on the ST modules
	1	At least one ST module is registering an error
7	0	Reserved
	1	

8 Technical details

General	312191	314191
Certifications	CE, EAC, KOSHA, TÜV, UKCA, cULus Listed	CE, EAC, KOSHA, TÜV, UKCA, cULus Listed
Application range	Standard/failsafe	Standard/failsafe
Module's device code	0800h	0800h
Application in system environment A		
from FS firmware version, other head modules	4	4
from ST firmware version, other head modules	5	5
from FS firmware version PSSu H F PN	1	1
from ST firmware version PSSu H S PN	1	1
from ST firmware version PSSu WR S IDN	6	6
Application in system environment B		
from FS firmware version, head modules	1.0.0	1.0.0
from ST firmware version, head modules	1.0.0	1.0.0
Electrical data	312191	314191
Supply voltage		
for	Module supply	Module supply
Voltage	24 V	24 V
Kind	DC	DC
Voltage tolerance	-30 %/+25 %	-30 %/+25 %
Current load capacity at UB	0,8 A	0,8 A
Inrush current that the external power supply must provide	4 A	4 A
Output of external power supply (DC)	12 W	12 W
Supply voltage		
for	Periphery supply	Periphery supply
Voltage	24 V	24 V
Kind	DC	DC
Voltage tolerance	-30 %/+25 %	-30 %/+25 %
Current load capacity at UB	10 A	10 A
Rated surge voltage	2500 V	1500 V
Potential isolation between module supply and periphery supply	2500 V	1500 V

Electrical data	312191	314191
Internal supply voltage (module supply)		
Output voltage	int. system	int. system
Voltage	5 V	5 V
Voltage tolerance	-2 %/+3 %	-2 %/+3 %
Module's power consumption	0,12 W	0,12 W
Potential isolation	2500 V	1500 V
Current load capacity	2 A	2 A
Buffer in the case of supply interruptions in accordance with	EN 61131-2	EN 61131-2
Short circuit-proof	Yes	Yes
Periphery's supply voltage (periphery supply)		
Module's current consumption with no load	5 mA	5 mA
Module's power consumption with no load	0,12 W	0,12 W
Max. power dissipation of module	2,5 W	2 W
Environmental data	312191	314191
Climatic suitability	EN 60068-2-1, EN 60068-2-14, EN 60068-2-2, EN 60068-2-30, EN 60068-2-78	EN 60068-2-1, EN 60068-2-14, EN 60068-2-2, EN 60068-2-30, EN 60068-2-78
Ambient temperature		
Temperature range	0 - 60 °C	-40 - 70 °C
Storage temperature		
Temperature range	-40 - 70 °C	-40 - 70 °C
Climatic suitability		
in accordance with the standard	EN 60068-2-78	EN 60068-2-78
Humidity	93 % r. h. at 40 °C	93 % r. h. at 40 °C
Condensation during operation	Not permitted	EN 60068-2-30, short-term
Max. operating height above SL	2000 m	5000 m
EMC	EN 61000-6-2, EN 61000-6-4, EN 61131-2	EN 61000-6-2, EN 61000-6-4, EN 61131-2
Vibration		
in accordance with the standard	EN 60068-2-6	EN 60068-2-6
Frequency	10 - 150 Hz	10 - 150 Hz
Acceleration	10 m/s²	10 m/s²
Broadband noise		
in accordance with the standard	–	EN 60068-2-64
Frequency	–	5 - 500 Hz
Acceleration	–	19 m/s² eff.
Shock stress		
in accordance with the standard	EN 60068-2-27	EN 60068-2-27
Number of shocks	6	6
Acceleration	150 m/s²	150 m/s²
Duration	11 ms	11 ms

Environmental data	312191	314191
Airgap creepage		
in accordance with the standard	EN 61131-2	EN 61131-2
Overvoltage category	II	II
Pollution degree	2	2
Protection type		
in accordance with the standard	EN 60529	EN 60529
Housing	IP20	IP20
Terminals	IP20	IP20
Mounting area (e.g. control cabinet)	IP54	IP54
Mechanical data	312191	314191
Material		
Bottom	PC	PC
Front	PC	PC
Coding	PA	PA
Mounting type	plug-in	plug-in
Dimensions		
Height	76 mm	76 mm
Width	25,2 mm	25,2 mm
Depth	60,2 mm	60,2 mm
Weight	57 g	60 g
Mechanical coding		
Type	C	C
Colour	Yellow	Yellow

Where standards are undated, the 2022-01 latest editions shall apply.

9 Supplementary data

9.1 Permitted operating height

The values stated in the technical details apply to the use of the device in operating heights up to max. 2000 m above SL. When used at higher levels, restrictions of the ambient temperature (standard IEC 61131-2) must be taken into account.

Operating height above SL [m]	Multiplication factors for the devices' ambient temperature
0 ... 2000	1.0
3000	0.9
4000	0.8
5000	0.7

10 Order reference

10.1 Product

Product type	Features	Order no.
PSSu E F PS1	Electronic module, base type	312191
PSSu E F PS1-T	Electronic module, T-type	314191

10.2 Accessories

Base modules

Product type	Features	Order no.
PSSu BS 2/8 S	Base module with screw terminals, for use only as the first module after the head module	312656
PSSu BS 2/8 S-T	Base module with screw terminals, for use only as the first module after the head module, T-type	314656
PSSu BS 2/8 C	Base module with cage clamp terminals, for use only as the first module after the head module	312657
PSSu BS 2/8 C-T	Base module with cage clamp terminals, for use only as the first module after the head module, T-type	314657
PSSu BS-R 2/8 S	Base module with screw terminals, for use only to refresh the voltage and form supply groups	312654
PSSu BS-R 2/8 S-T	Base module with screw terminals, for use only to refresh the voltage and form supply groups, T-type	314654
PSSu BS-R 2/8 C	Base module with cage clamp terminals, for use only to refresh the voltage and form supply groups	312655
PSSu BS-R 2/8 C-T	Base module with cage clamp terminals, for use only to refresh the voltage and form supply groups, T-type	314655

11 **EC declaration of conformity**

This product/these products meet the requirements of the directive 2006/42/EC on machinery of the European Parliament and of the Council. The complete EC Declaration of Conformity is available on the Internet at www.pilz.com/downloads.

Representative: Pilz GmbH & Co. KG, Felix-Wankel-Str. 2, 73760 Ostfildern, Germany

12 UKCA-Declaration of Conformity

This product(s) complies with following UK legislation: Supply of Machinery (Safety) Regulation 2008.

The complete UKCA Declaration of Conformity is available on the Internet at www.pilz.com/downloads.

Representative: Pilz Automation Technology, Pilz House, Little Colliers Field, Corby, Northamptonshire, NN18 8TJ United Kingdom, eMail: mail@pilz.co.uk

► Support

Technical support is available from Pilz round the clock.

Americas

Brazil

+55 11 97569-2804

Canada

+1 888 315 7459

Mexico

+52 55 5572 1300

USA (toll-free)

+1 877-PILZUSA (745-9872)

Asia

China

+86 400-088-3566

Japan

+81 45 471-2281

South Korea

+82 31 778 3300

Australia and Oceania

Australia

+61 3 95600621

New Zealand

+64 9 6345350

Europe

Austria

+43 1 7986263-444

Belgium, Luxembourg

+32 9 3217570

France

+33 3 88104003

Germany

+49 711 3409-444

Ireland

+353 21 4804983

Italy, Malta

+39 0362 1826711

Scandinavia

+45 74436332

Spain

+34 938497433

Switzerland

+41 62 88979-32

The Netherlands

+31 347 320477

Türkiye

+90 216 5775552

United Kingdom

+44 1536 462203

You can reach our international hotline on:

+49 711 3409-222

support@pilz.com

Pilz develops environmentally-friendly products using ecological materials and energy-saving technologies. Offices and production facilities are ecologically designed, environmentally-aware and energy-saving. So Pilz offers sustainability, plus the security of using energy-efficient products and environmentally-friendly solutions.



CECE[®], CHRE[®], CMSE[®], INDUSTRIAL P[®], Leansafe[®], Myzel[®], PAS4000[®], PASscal[®], PASconfig[®], Pilz[®], PIT[®], PMSprimo[®], PMSprotego[®], PMCiendo[®], PMD[®], PME[®], PNOZ[®], Primo[®], PSEN[®], PSS[®], PSS[®], PVIS[®], SafetyBUS p[®], SafetyNET p[®], THE SPIRIT OF SAFETY[®] are registered and protected trademarks of Pilz GmbH & Co. KG in some countries. We would point out that product features may vary from the details stated in this document, depending on the status at the time of publication and the scope of the equipment. We accept no responsibility for the validity, accuracy and entirety of the text and graphics presented in this information. Please contact our Technical Support if you have any questions.

21298-EN-08, 2023-08 Printed in Germany
© Pilz GmbH & Co. KG, 2019

We are represented internationally. Please refer to our homepage www.pilz.com for further details or contact our headquarters.

Headquarters: Pilz GmbH & Co. KG, Felix-Wankel-Straße 2, 73760 Ostfildern, Germany
Telephone: +49 711 3409-0, E-Mail: info@pilz.com, Internet: www.pilz.com

PILZ
THE SPIRIT OF SAFETY