



## PSSu E S PD-D

**PILZ**  
THE SPIRIT OF SAFETY

- ▶ Decentralised system PSSuniversal I/O

This document is the original document.

Where unavoidable, for reasons of readability, the masculine form has been selected when formulating this document. We do assure you that all persons are regarded without discrimination and on an equal basis.

All rights to this documentation are reserved by Pilz GmbH & Co. KG. Copies may be made for the user's internal purposes. Suggestions and comments for improving this documentation will be gratefully received.

Pilz®, PIT®, PMI®, PNOZ®, Primo®, PSEN®, PSS®, PVIS®, SafetyBUS p®, SafetyEYE®, SafetyNET p®, the spirit of safety® are registered and protected trademarks of Pilz GmbH & Co. KG in some countries.



SD means Secure Digital

<b>1</b>	<b>Introduction</b> .....	<b>5</b>
1.1	Validity of documentation .....	5
1.1.1	Retaining the documentation .....	5
1.1.2	Terminology: System environment A and B .....	5
1.2	Definition of symbols .....	6
<b>2</b>	<b>Overview</b> .....	<b>7</b>
2.1	Module structure .....	7
2.2	Module features .....	7
2.3	Front view .....	8
<b>3</b>	<b>Safety</b> .....	<b>10</b>
3.1	Intended use .....	10
3.2	Safety regulations .....	11
3.2.1	Use of qualified personnel .....	11
3.2.2	Warranty and liability .....	11
3.2.3	Disposal .....	11
<b>4</b>	<b>Function description</b> .....	<b>12</b>
4.1	Block diagram .....	12
4.2	Module features .....	12
4.2.1	Functions .....	12
4.2.2	Integrated protection mechanisms .....	12
4.3	Configuration .....	13
4.3.1	PSSu assignment in system environment A .....	13
4.3.1.1	Addresses in the process image .....	13
4.3.1.2	Status byte .....	13
4.3.2	PSSu assignment in system environment B .....	14
<b>5</b>	<b>Installation</b> .....	<b>15</b>
5.1	General installation guidelines .....	15
5.1.1	Dimensions .....	15
5.2	Installing the base module .....	16
5.3	Inserting and removing an electronic module .....	17
5.3.1	Inserting an electronic module .....	18
5.3.2	Removing an electronic module .....	19
5.3.3	Changing an electronic module during operation .....	19
<b>6</b>	<b>Wiring</b> .....	<b>20</b>
6.1	General wiring guidelines .....	20
6.1.1	Mechanical connection of the base modules .....	20
6.2	Terminal configuration .....	22
<b>7</b>	<b>Operation</b> .....	<b>24</b>
7.1	Messages .....	24
7.2	Display elements .....	25
7.2.1	Display elements for module diagnostics .....	25
7.2.2	Display elements for output status .....	25

<b>8</b>	<b>Technical Details</b> .....	<b>26</b>
<b>9</b>	<b>Order reference</b> .....	<b>28</b>
9.1	Product .....	28
9.2	Accessories .....	28

# 1 Introduction

## 1.1 Validity of documentation

This documentation is valid for the product PSSu E S PD-D. It is valid until new documentation is published.

This operating manual explains the function and operation, describes the installation and provides guidelines on how to connect the product.

Electronic module operates as distributor for periphery supply, with advanced diagnostics.

### 1.1.1 Retaining the documentation

This documentation is intended for instruction and should be retained for future reference.

### 1.1.2 Terminology: System environment A and B

The PSSu system can be used in two different system environments. The module's application area is described in the chapter "Intended Use" of the manual.

The distinction is made between

- ▶ PSSu in system environment A
- ▶ PSSu in system environment B

The distinction is based on the application area of the PSSu system.

PSSu in system environment A may be used in the

- ▶ Decentralised system PSSu I/O
- ▶ **Not** in the automation system PSS 4000

PSSu in system environment B may be used in the

- ▶ Automation system PSS 4000, e.g. with
  - Decentralised system PSSu I/O with SafetyNET p
  - Control system PSSu PLC
  - Control system PSSu multi

## 1.2 Definition of symbols

Information that is particularly important is identified as follows:



### **DANGER!**

This warning must be heeded! It warns of a hazardous situation that poses an immediate threat of serious injury and death and indicates preventive measures that can be taken.



### **WARNING!**

This warning must be heeded! It warns of a hazardous situation that could lead to serious injury and death and indicates preventive measures that can be taken.



### **CAUTION!**

This refers to a hazard that can lead to a less serious or minor injury plus material damage, and also provides information on preventive measures that can be taken.



### **NOTICE**

This describes a situation in which the product or devices could be damaged and also provides information on preventive measures that can be taken. It also highlights areas within the text that are of particular importance.



### **INFORMATION**

This gives advice on applications and provides information on special features.

## 2 Overview

### 2.1 Module structure

A module consists of

- ▶ Electronic module and
- ▶ Base module with
  - Screw terminals or
  - Cage clamp terminals

The base modules are the carrier units for the electronic modules and are used to connect the field wiring. The electronic modules are inserted on to the base modules and determine the module's function.

Details of the base modules that can be used are available in the chapter entitled “Intended Use”.

### 2.2 Module features

The product has the following features:

- ▶ Outputs for periphery supply: 4
- ▶ Current load capacity per output: 1,5 A
  - Short circuit-proof
  - Overload-proof
- ▶ LEDs for:
  - Switch status of each output
  - Module error
- ▶ The module provides advanced diagnostic data.
- ▶ Optional access to the advanced diagnostic data in the process image (system environment A only)

## 2.3 Front view

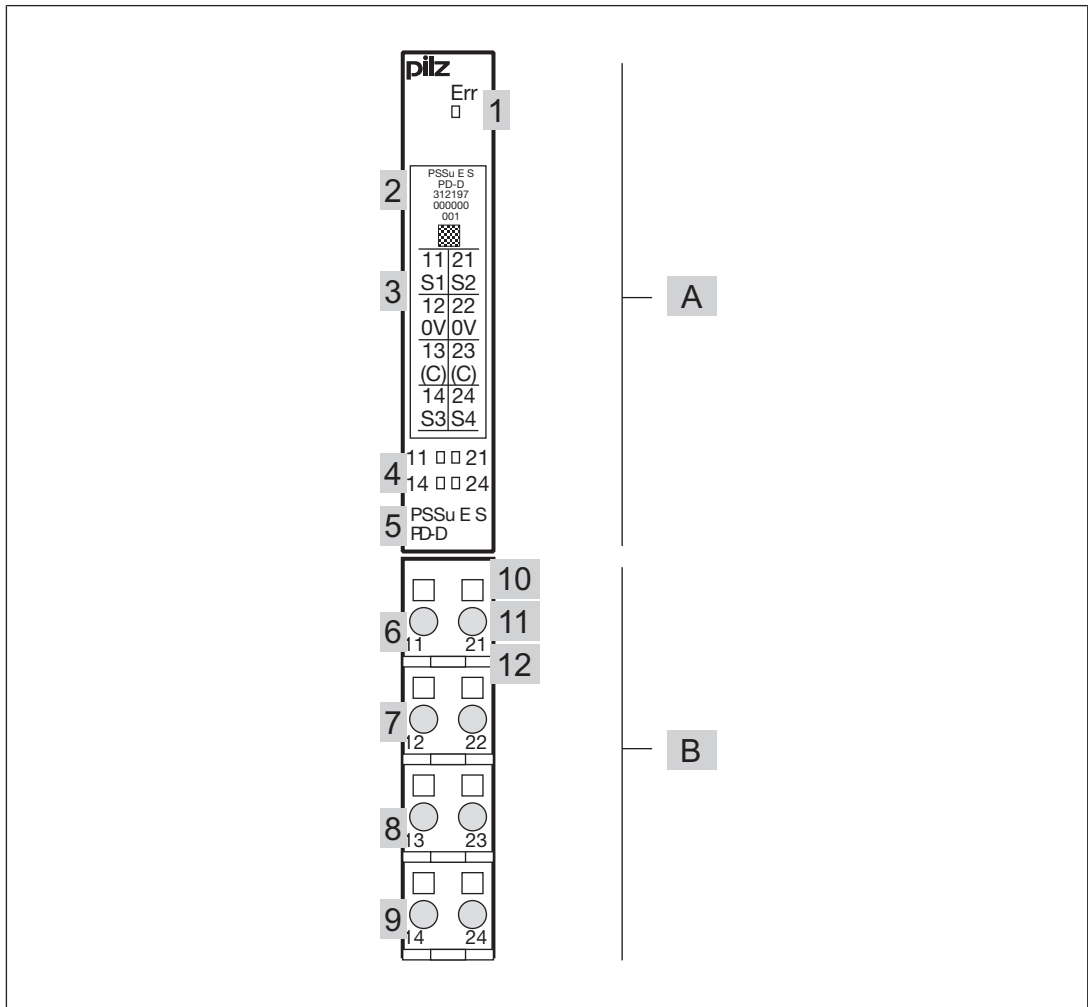

### Legend:

- ▶ A: Electronic module
- ▶ B: Base module
- ▶ 1: LED for module diagnostics
- ▶ 2: Labelling strip with:
  - Name of electronic module
  - Order number
  - Serial number
  - Hardware version number
  - 2D code
- ▶ 3: Labelling strip for the terminal configuration on the base module
- ▶ 4: Status LEDs
- ▶ 5: Name of electronic module
- ▶ 6: Connection level 1
- ▶ 7: Connection level 2
- ▶ 8: Connection level 3



- ▶ 9: Connection level 4
- ▶ 10: Square mounting holes (connection levels 1, 2, 3 and 4)
  - With screw to loosen/tighten the screw terminal on base modules with screw terminals
  - With mechanism to operate the cage clamp on base modules with cage clamp terminals
- ▶ 11: Round connection holes (connection levels 1, 2, 3 and 4) for connecting the signal lines
- ▶ 12: Mounting slot for colour marker to label the connection level (connection levels 1, 2, 3 and 4)

## 3 Safety

### 3.1 Intended use

The module may be used for standard applications in system environment A and B.

The module may be used for additional connections to the periphery supply. The periphery supply can be drawn from the connections, but may not be fed through that route.

Intended use includes making the electrical installation EMC-compliant. Please refer to the guidelines stated in the "PSSuniversal Installation Manual". The module is designed for use in an industrial environment. It is not suitable for use in a domestic environment, as this can lead to interference.

The following is deemed improper use in particular:

- ▶ Any component, technical or electrical modification to the module
- ▶ Use of the module outside the areas described in this manual
- ▶ Any use of the module that is not in accordance with the technical details.



#### INFORMATION

The module is supported by:

- ▶ PSSuniversal Configurator and PSSuniversal Assistant from Version 1.6.0
- ▶ PAS4000 from version 1.8.0
  - We recommend that you always use the latest version (download from [www.pilz.de](http://www.pilz.de)).

The PSSu E S PD-D module may be used in conjunction with the following base modules:

- ▶ PSSu BP 1/8 S
- ▶ PSSu BP 1/8 C
- ▶ PSSu BP-C 1/8 S
- ▶ PSSu BP-C 1/8 C
- ▶ PSSu BP 1/12 S
- ▶ PSSu BP 1/12 C
- ▶ PSSu BP-C1 1/12 S
- ▶ PSSu BP-C1 1/12 C

## **3.2 Safety regulations**

### **3.2.1 Use of qualified personnel**

The products may only be assembled, installed, programmed, commissioned, operated, maintained and decommissioned by persons who are competent to do so.

A competent person is a qualified and knowledgeable person who, because of their training, experience and current professional activity, has the specialist knowledge required. To be able to inspect, assess and operate devices, systems and machines, the person has to be informed of the state of the art and the applicable national, European and international laws, directives and standards.

It is the company's responsibility only to employ personnel who

- ▶ Are familiar with the basic regulations concerning health and safety / accident prevention,
- ▶ Have read and understood the information provided in the section entitled Safety
- ▶ Have a good knowledge of the generic and specialist standards applicable to the specific application.

### **3.2.2 Warranty and liability**

All claims to warranty and liability will be rendered invalid if

- ▶ The product was used contrary to the purpose for which it is intended,
- ▶ Damage can be attributed to not having followed the guidelines in the manual,
- ▶ Operating personnel are not suitably qualified,
- ▶ Any type of modification has been made (e.g. exchanging components on the PCB boards, soldering work etc.).

### **3.2.3 Disposal**

- ▶ In safety-related applications, please comply with the mission time  $T_M$  in the safety-related characteristic data.
- ▶ When decommissioning, please comply with local regulations regarding the disposal of electronic devices (e.g. Electrical and Electronic Equipment Act).

## 4 Function description

### 4.1 Block diagram

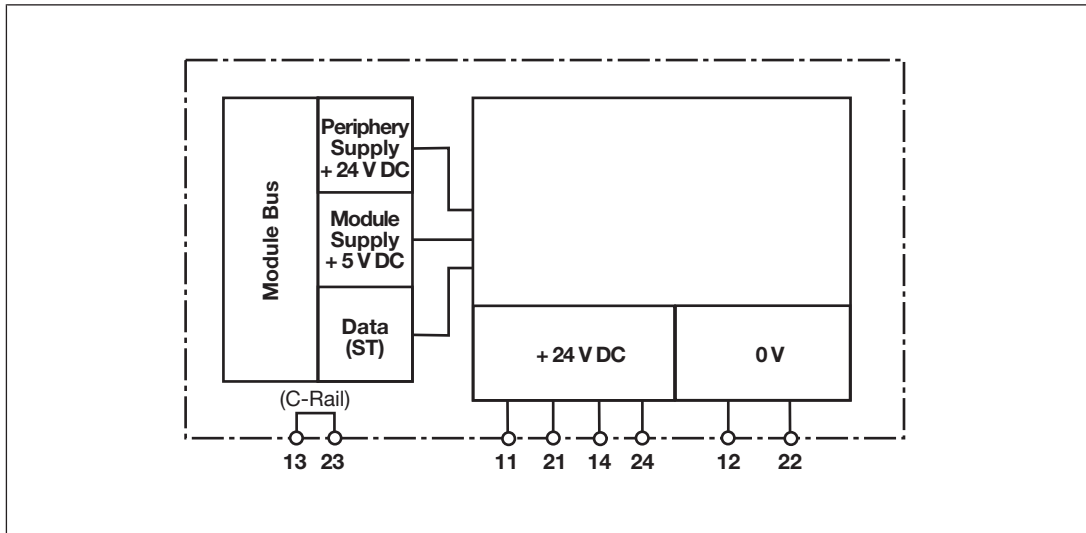

### 4.2 Module features

#### 4.2.1 Functions

- ▶ The module routes the periphery supply from the module bus to the base module terminals.
- ▶ The periphery supply is available at the outputs.

The module provides advanced diagnostic data, which is also available in a status byte in the ST-PII (not in system environment B):

- ▶ Output overload/short circuit
- ▶ Excess module temperature

#### 4.2.2 Integrated protection mechanisms

When the PSSu E F PS1(-T) or PSSu E F PS2(-T)(-R) is used to supply the system, the module supply is buffered for 20 ms if the supply voltage is interrupted.

The module provides the following diagnostic data:

- ▶ Start-up error
- ▶ Configuration error
- ▶ ST communication error
- ▶ Bus termination error
- ▶ Output overload
- ▶ Temperature error: too warm
- ▶ Temperature error: too hot

## 4.3 Configuration

### 4.3.1 PSSu assignment in system environment A

It is not necessary to configure ST outputs in the PSSuniversal Configurator on the PSS WIN-PRO system software. Overload detection and temperature monitoring can be configured: The entries in the status byte can be deactivated.

Further information on configuration is available in the PSSuniversal Configurator's online help.

#### 4.3.1.1 Addresses in the process image

The module occupies 8 consecutive bit addresses for the status byte in the ST-PII, if the status byte is configured.

Configuration	SafetyBUS p	Standard bus system	
	FS-PIO	ST-PII	ST-PIO
Without status byte	---	---	---
With status byte ("S")	---	8 Bit	---

#### 4.3.1.2 Status byte

The status byte contains the information on overload and overtemperature.

Structure and contents of the status byte:

Bit number	Signal	Key
0	0	No overload on output S1
	1	Overload on output S1
1	0	No overload on output S2
	1	Overload on output S2
2	0	No overload on output S3
	1	Overload on output S3
3	0	No overload on output S4
	1	Overload on output S4
4	0	No temperature error
	1	Temperature error: too warm
5	0	Switch-off temperature not reached.
	1	Temperature error: too hot. Outputs switch off.
6	0	Reserved
	1	Reserved
7	0	Reserved
	1	Reserved

### **4.3.2 PSSu assignment in system environment B**

The module does not have to be configured.

## 5 Installation

### 5.1 General installation guidelines

Please also refer to the PSSuniversal Installation Manual.



#### NOTICE

Damage due to electrostatic discharge!

Electrostatic discharge can damage components. Ensure against discharge before touching the product, e.g. by touching an earthed, conductive surface or by wearing an earthed armband.

#### 5.1.1 Dimensions

Base modules with four connection levels:

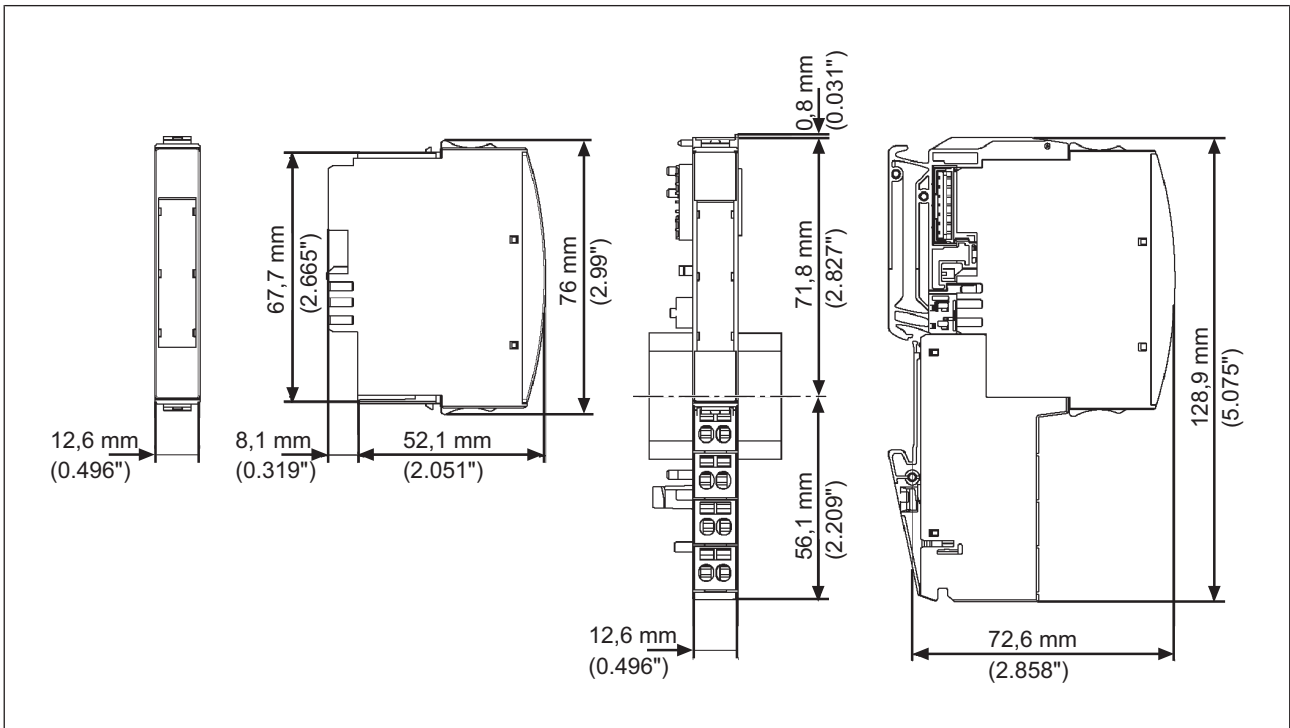

Base modules with six connection levels:

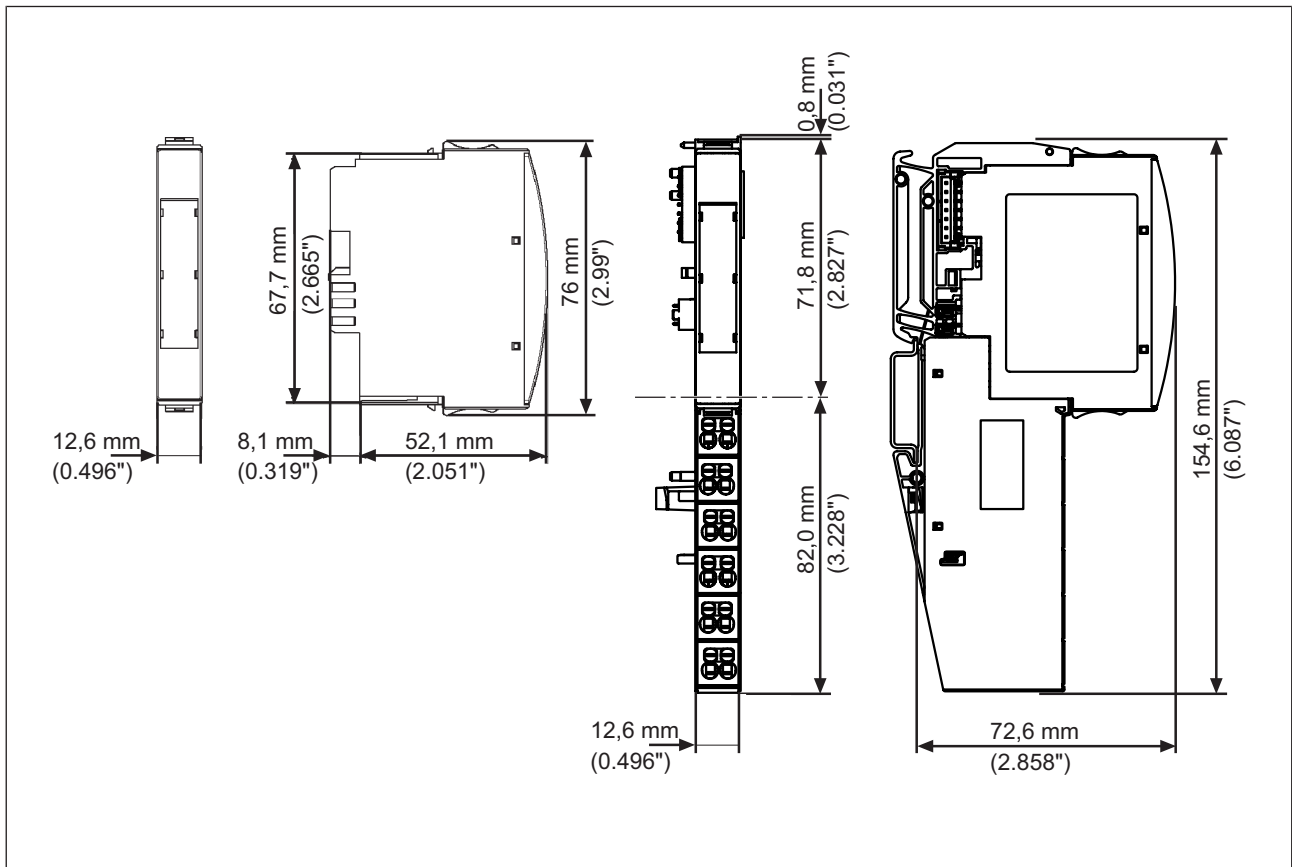

## 5.2 Installing the base module

Prerequisite:

- ▶ The head module must be installed.
- ▶ If the head module does not have an integrated power supply, a supply voltage module must be installed to the right of the head module.

Please note:

- ▶ For mechanical reasons it is not possible to mix base modules with screw terminals and base modules with cage clamp terminals.
- ▶ All contacts should be protected from contamination.
- ▶ The mechanics of the base modules are designed for 50 plug in/out cycles.

Procedure:

- ▶ We recommend that you wire up the base modules before inserting the electronic modules.
- ▶ Slot the groove on the base module on to the mounting rail from below [1].
- ▶ Push the base module back [2] until you hear it lock into position.
- ▶ On the mounting rail, slide the base module to the left until you hear the two lateral mounting hooks on the adjacent module lock into position [3].



Schematic representation:

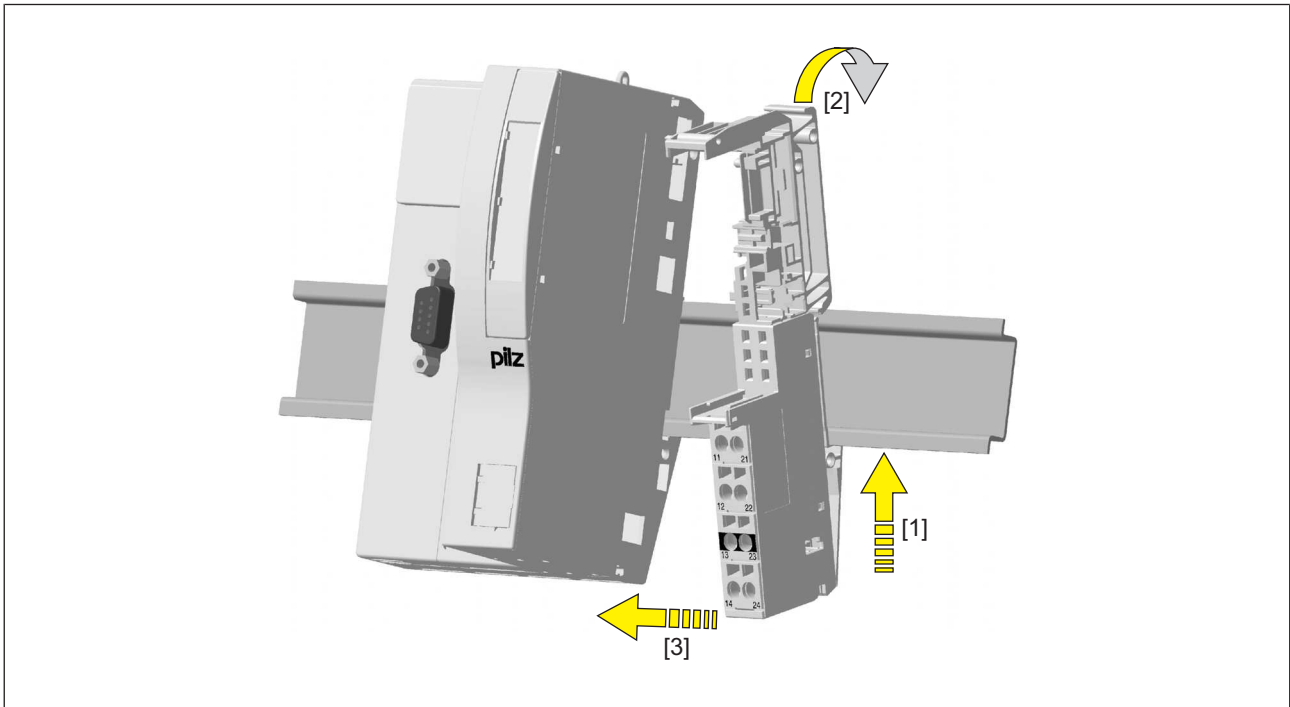

### 5.3 Inserting and removing an electronic module

Please note:

- ▶ Only insert on to base modules that are already installed.
- ▶ Preferably these base modules should be ready wired.
- ▶ Electronic modules with outputs may only be inserted and removed when the load is switched off. Unforeseeable error reactions may be triggered if modules are inserted and removed under load.
- ▶ When an electronic module is plugged into a base module for the first time, one part of the coding element remains on the electronic module, while its counterpart is fixed on to the base module. This is how the base module is coded.
- ▶ The mechanics of the electronic modules are designed for 50 plug in/out cycles.

### 5.3.1 Inserting an electronic module

Procedure:

- ▶ The electronic module must audibly lock into position [1].
- ▶ Mark the electronic module using the labelling strips [2].

Schematic representation:

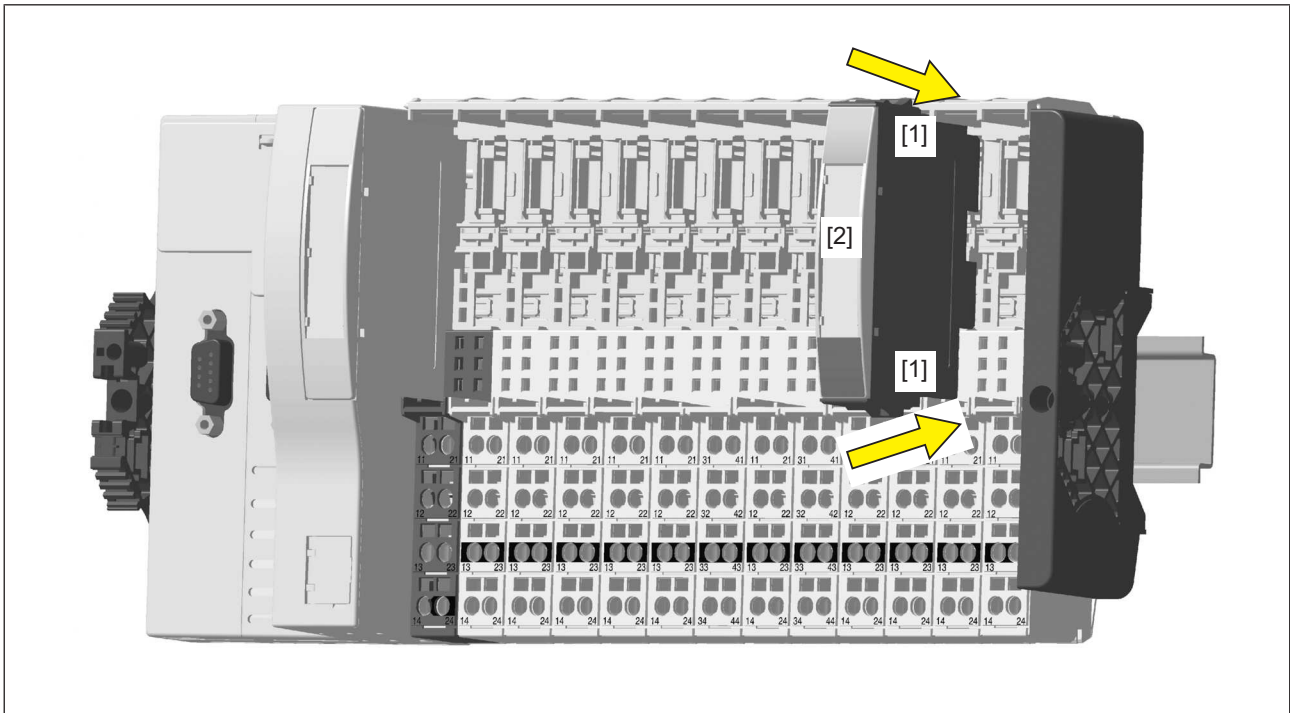

### 5.3.2 Removing an electronic module

Procedure:

- ▶ Press the locking mechanisms [1] together simultaneously.
- ▶ Pull out the electronic module [2].

Schematic representation:

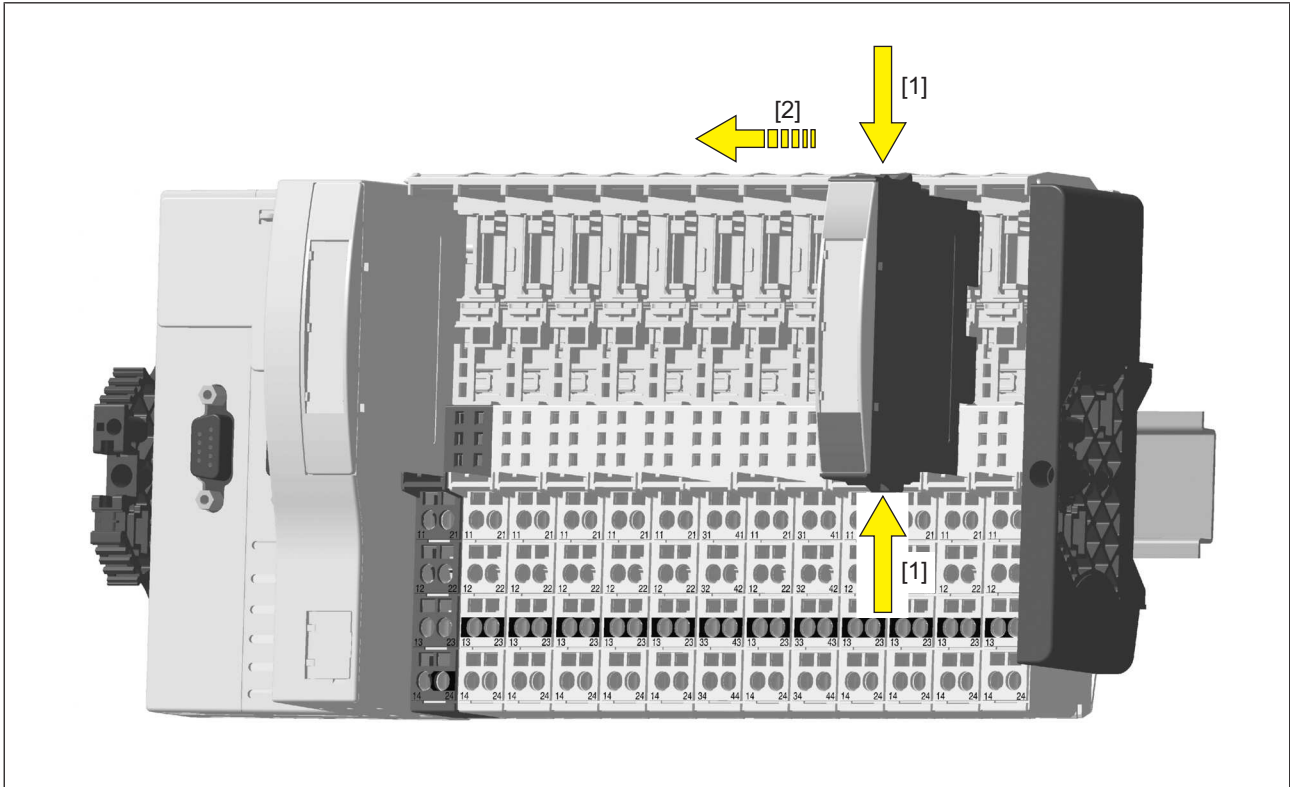

### 5.3.3 Changing an electronic module during operation

It is possible to change an electronic module during operation. The configuration data is retained when a module is changed.

Effects:

- ▶ System environment A:
  - In the event of a potential FS communication error, the FS section of the PSSu system and all relevant I/O-Groups (SafetyBUS p) switch to a STOP condition.
- ▶ System environment B:
  - All FS hardware outputs on the PSSu system switch to a safe condition.
  - The substitute values are used for the modules' FS outputs, with Valid Bits = FALSE.



**CAUTION!**

Sparking can cause interference and errors!

Only change the module when the load is switched off!

## 6 Wiring

### 6.1 General wiring guidelines

Please note:

- ▶ Use copper wiring.
- ▶ The terminal configuration as stated on the front plate applies for base modules with C-rail. The terminal configuration as stated in the technical documentation applies for all other base modules.

#### 6.1.1 Mechanical connection of the base modules

Procedure:

- ▶ Use a flat blade screwdriver (DIN 5264-A)!

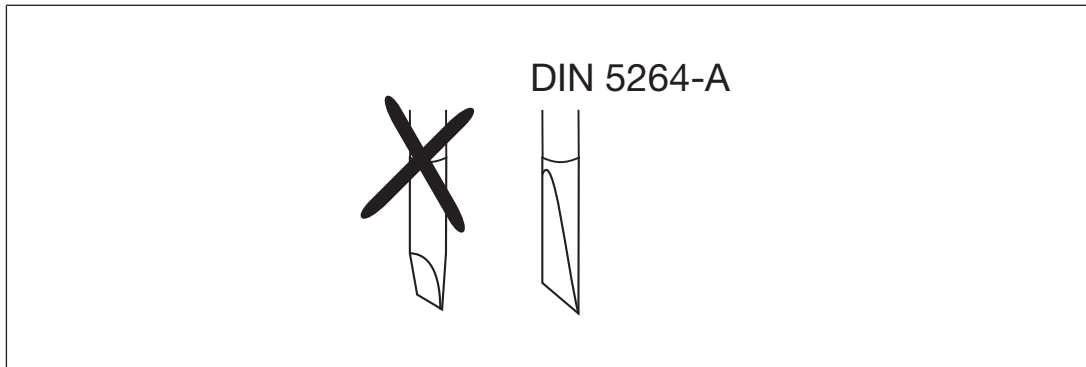

- ▶ Strip the wire back 8 mm.
- ▶ If necessary, label the connection level with a colour marker [3].
- ▶ Base module with screw terminals:
  - Use a screwdriver to loosen the screw on the screw terminal [1]
  - Insert the stripped cable into the round fixing hole [2], as far as it will go.
  - Tighten up the screw on the screw terminal.
  - Check that the cable is firmly seated.
- ▶ Base module with cage clamp terminals:
  - Insert the screwdriver [4] into the square hole [1].
  - Insert the stripped cable into the round fixing hole [2], as far as it will go [5].
  - Pull out the screwdriver [6].
  - Check that the cable is firmly seated.

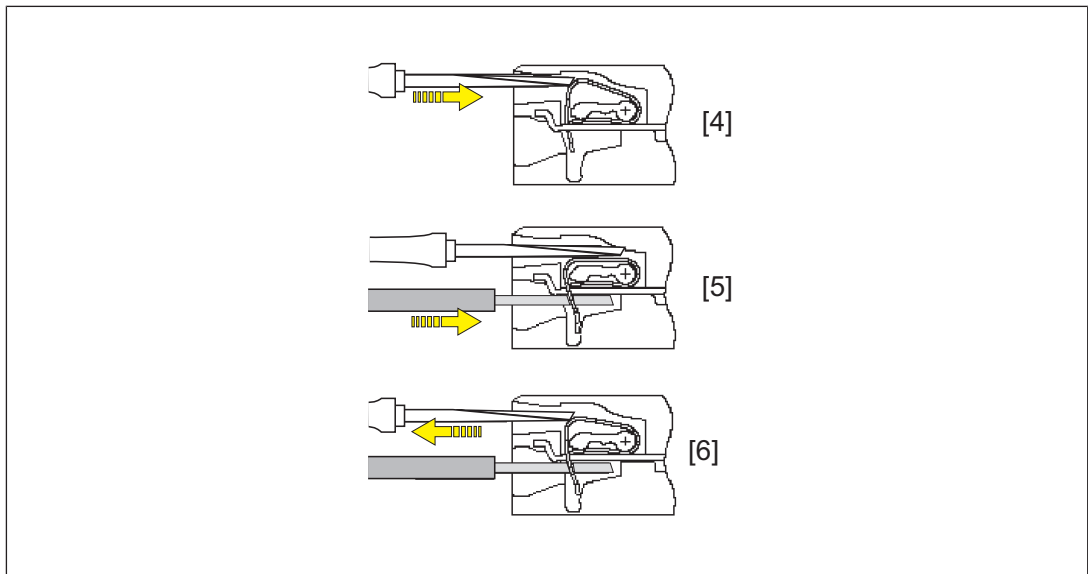
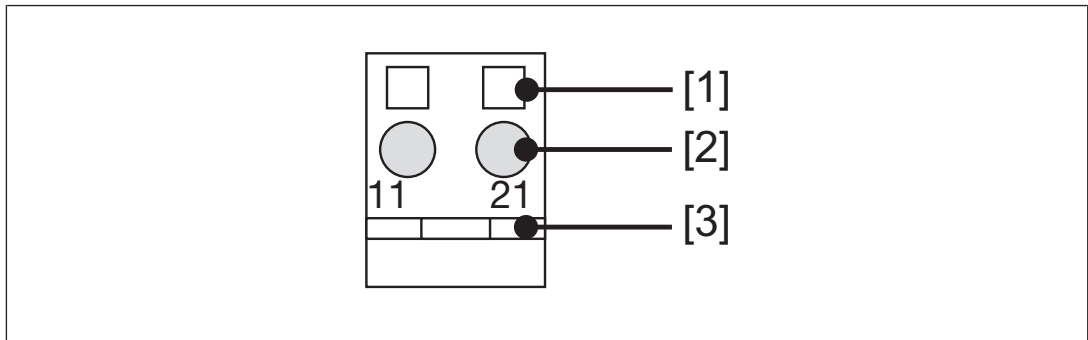

Please note:

- ▶ The minimum cable cross section for field connection terminals on the base modules is 0.14 mm<sup>2</sup> (AWG26).
- ▶ The maximum cable cross section for field connection terminals is:
  - Digital inputs: 1.5 mm<sup>2</sup> (AWG16)
  - Digital outputs: 2.0 mm<sup>2</sup> (AWG14)
  - Inputs/outputs on the counter modules: 1.5 mm<sup>2</sup> (AWG16)
  - Analogue inputs/outputs: 1.5 mm<sup>2</sup> (AWG16)
  - Communication cables: 1.5 mm<sup>2</sup> (AWG16)
  - Test pulse outputs: 1.5 mm<sup>2</sup> (AWG16)
  - Power supply: 2.5 mm<sup>2</sup> (AWG12)
  - Functional earth: 2.5 mm<sup>2</sup> (AWG12)

- ▶ On base modules with screw terminals:
  - If you use a multi-strand cable to connect the I/Os, it is recommended that you use ferrules conforming to Parts 1 and 2 of DIN 46228, 0.14 ... 1.5 mm<sup>2</sup>, Form A or C, although this is not essential. To crimp the ferrules you can use crimp pliers (crimp form A or C) conforming to EN 60947-1, such as the PZ 1.5 or PZ 6.5 from Weidmüller, for example.
  - Maximum torque setting: 0.8 Nm
- ▶ Use copper wiring.

## 6.2 Terminal configuration

Base module	Terminal configuration	
Screw terminals: PSSu BP 1/8 S  Cage clamp terminals: PSSu BP 1/8 C	Without C-rail:  11: Output S1  21: Output S2  12 -22: 0 V periphery supply (12-22 linked within the base module)  13 -23: 0 V periphery supply (13-23 linked within the base module)  14: Output S3  24: Output S4	

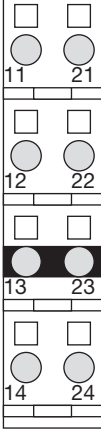
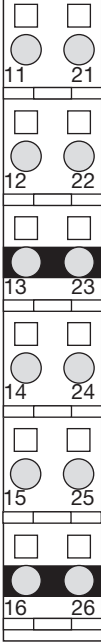
Base module	Terminal configuration	
<p>Screw terminals: PSSu BP-C 1/8 S</p> <p>Cage clamp terminals: PSSu BP-C 1/8 C</p>	<p>With C-rail:</p> <p>11: Output S1</p> <p>21: Output S2</p> <p>12 -22: 0 V periphery supply (12-22 linked within the base module)</p> <p>13 -23: C-rail supply (13-23 linked within the base module)</p> <p>14: Output S3</p> <p>24: Output S4</p>	
<p>Screw terminals: PSSu BP-C1 1/12 S</p> <p>Cage clamp terminals: PSSu BP-C1 1/12 C</p>	<p>With C-rail:</p> <p>11: Output S1</p> <p>21: Output S2</p> <p>12 -22: 0 V periphery supply (12-22 linked within the base module)</p> <p>13 -23: C-rail supply (13-23-16-26 linked within the base module)</p> <p>14: Output S3</p> <p>24: Output S4</p> <p>15 -25: 0 V periphery supply (15-25 linked within the base module)</p> <p>16 -26: C-rail supply (13-23-16-26 linked within the base module)</p>	

## 7 Operation

### 7.1 Messages

An error will be signalled to the head module and will be entered in the head module's error stack. A module error will also be displayed via the "Err" LED (see section entitled "Display elements").

The module can detect the following errors:

Errors	Explanation	Remedy
Start-up error	Error as the PSSu system starts up	Change faulty module.
Configuration error	Incorrect module type configured.	The configured hardware registry does not match the actual hardware registry.
ST communication error	Error during ST communication	Change faulty module.
Bus termination error	There is no terminating plate or there is a bad contact with the module bus.	Install a terminating plate with integrated end bracket or insert the base modules together correctly.
Overload/short circuit	Load on output too high.	Rectify overload or short circuit.
Temperature error: too warm <sup>(1)</sup>	Ambient temperature too high: Error stack entry	Ensure there is sufficient ventilation in the control cabinet or prevent overload.
Temperature error: too hot <sup>(1)</sup>	Ambient temperature too high: Outputs are switched off	Ensure there is sufficient ventilation in the control cabinet or prevent overload.

<sup>(1)</sup> There are two levels of overtemperature.

▶ Too warm:

If a module's temperature exceeds a threshold value, the module sends a warning to the head module. If the temperature drops back below the threshold value, the module sends an all-clear.

▶ Too hot:

If a module's temperature exceeds a further threshold value, the module sends an error message to the head module and switches off the outputs.

▶ After the "too hot" message has been received, if the temperature drops back below the "too warm" threshold value, the outputs will switch back on.

Further information on PSSu error messages is available in the online help for the PSSuniversal Assistant system software.





## 7.2 Display elements

### Legend

-  LED on
-  LED off



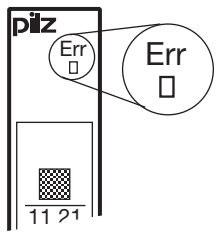



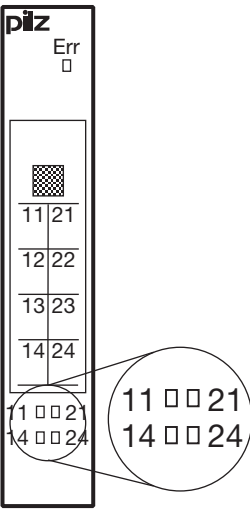

### 7.2.1 Display elements for module diagnostics

The module has an LED for displaying module errors ("Err" LED).

	LED			Meaning
	Designation	Colour	Status	
	Err	---		No error
	Red		Module is faulty	

### 7.2.2 Display elements for output status

Each output is assigned an LED for displaying the output status (LEDs "11", "21", "14" and "24")

	LED			Key	
	Descrip-tion	Colour	Status	Output	Terminal
	11	---		Overload on output S1	11
		green		No overload on output S1	
	21	---		Overload on output S2	21
		green		No overload on output S2	
	14	---		Overload on output S3	14
		green		No overload on output S3	
	24	---		Overload on output S4	24
		green		No overload on output S4	

## 8 Technical Details

<b>General</b>	
Certifications	<b>CE, UKCA, cULus Listed</b>
Application range	<b>Standard</b>
Module's device code	<b>000Ah</b>
Application in system environment A	
From ST firmware version, other head modules	<b>16</b>
From ST firmware version PSSu H S PN	<b>1</b>
Application in system environment B	
From ST firmware version, head modules	<b>1.8.0</b>
<b>Electrical data</b>	
Internal supply voltage (module supply)	
Module's power consumption	<b>0,3 W</b>
Periphery's supply voltage (periphery supply)	
Voltage range	<b>16,8 - 30 V</b>
Module's current consumption with no load	<b>30 mA</b>
Module's power consumption with no load	<b>0,72 W</b>
Max. power dissipation of module	<b>1,5 W</b>
<b>Semiconductor outputs</b>	
Rated voltage	<b>24 V DC</b>
Typ. threshold value for overload	<b>8 A</b>
Permitted loads	<b>inductive, capacitive, resistive</b>
<b>Voltage outputs</b>	
Number of outputs for periphery supply	<b>4</b>
Max. output current at rated voltage	<b>1,5 A</b>
Short circuit-proof	<b>yes</b>
Potential isolation between output and voltage for the internal module bus	<b>yes</b>
<b>Environmental data</b>	
Climatic suitability	<b>EN 60068-2-1, EN 60068-2-14, EN 60068-2-2, EN 60068-2-30, EN 60068-2-78</b>
Ambient temperature	
In accordance with the standard	<b>EN 60068-2-14</b>
Temperature range	<b>0 - 60 °C</b>
Storage temperature	
In accordance with the standard	<b>EN 60068-2-1/-2</b>
Temperature range	<b>-25 - 70 °C</b>
Climatic suitability	
In accordance with the standard	<b>EN 60068-2-30, EN 60068-2-78</b>
Humidity	<b>93 % r. h. at 40 °C</b>
Condensation during operation	<b>Not permitted</b>
Max. operating height above sea level	<b>2000 m</b>
EMC	<b>EN 61000-4-2, EN 61000-4-3, EN 61000-4-4, EN 61000-4-5, EN 61000-4-6, EN 61131-2</b>

### Environmental data

#### Vibration

In accordance with the standard	<b>EN 60068-2-6</b>
Frequency	<b>10 - 150 Hz</b>
Acceleration	<b>1g</b>

#### Shock stress

In accordance with the standard	<b>EN 60068-2-27</b>
Number of shocks	<b>6</b>
Acceleration	<b>15g</b>
Duration	<b>11 ms</b>
In accordance with the standard	<b>EN 60068-2-27</b>
Number of shocks	<b>1000</b>
Acceleration	<b>10g</b>
Duration	<b>16 ms</b>

#### Airgap creepage

In accordance with the standard	<b>EN 60664-1, EN 61131-2</b>
Overvoltage category	<b>II</b>
Pollution degree	<b>2</b>

#### Protection type

In accordance with the standard	<b>EN 60529</b>
Housing	<b>IP20</b>
Mounting area (e.g. control cabinet)	<b>IP54</b>

### Mechanical data

#### Material

Bottom	<b>PC</b>
Front	<b>PC</b>
Coding	<b>PA</b>

#### Dimensions

Height	<b>76 mm</b>
Width	<b>12,6 mm</b>
Depth	<b>60,2 mm</b>

Weight	<b>32 g</b>
--------	-------------

#### Mechanical coding

Type	<b>J</b>
Colour	<b>Dark grey</b>

Where standards are undated, the 2008-04 latest editions shall apply.

## 9 Order reference

### 9.1 Product

Product type	Features	Order No.
PSSu E S PD-D	Electronic module, base type	312 197

### 9.2 Accessories

#### Base modules

Product type	Features	Order No.
PSSu BP 1/8 S	Base module without C-rail with screw terminals	312 600
PSSu BP 1/8 C	Base module without C-rail with cage clamp terminals	312 601
PSSu BP-C 1/8 S	Base module with C-rail and screw terminals	312 610
PSSu BP-C 1/8 C	Base module with C-rail and cage clamp terminals	312 611
PSSu BP 1/12 S	Base module without C-rail with screw terminals	312 618
PSSu BP 1/12 C	Base module without C-rail with cage clamp terminals	312 619
PSSu BP-C1 1/12 S	Base module with C-rail and screw terminals	312 622
PSSu BP-C1 1/12 C	Base module with C-rail and cage clamp terminals	312 623

# ► Support

Technical support is available from Pilz round the clock.

## Americas

### Brazil

+55 11 97569-2804

### Canada

+1 888 315 7459

### Mexico

+52 55 5572 1300

### USA (toll-free)

+1 877-PILZUSA (745-9872)

## Asia

### China

+86 21 60880878-216

### Japan

+81 45 471-2281

### South Korea

+82 31 778 3300

## Australia and Oceania

### Australia

+61 3 95600621

### New Zealand

+64 9 6345350

## Europe

### Austria

+43 1 7986263-0

### Belgium, Luxembourg

+32 9 3217570

### France

+33 3 88104003

### Germany

+49 711 3409-444

### Ireland

+353 21 4804983

### Italy, Malta

+39 0362 1826711

## Scandinavia

+45 74436332

## Spain

+34 938497433

## Switzerland

+41 62 88979-32

## The Netherlands

+31 347 320477

## Turkey

+90 216 5775552

## United Kingdom

+44 1536 462203

## You can reach our international hotline on:

+49 711 3409-222

support@pilz.com

Pilz develops environmentally-friendly products using ecological materials and energy-saving technologies. Offices and production facilities are ecologically designed, environmentally-aware and energy-saving. So Pilz offers sustainability, plus the security of using energy-efficient products and environmentally-friendly solutions.



We are represented internationally. Please refer to our homepage [www.pilz.com](http://www.pilz.com) for further details or contact our headquarters.

Headquarters: Pilz GmbH & Co. KG, Felix-Wankel-Straße 2, 73760 Ostfildern, Germany  
Telephone: +49 711 3409-0, Telefax: +49 711 3409-133, E-Mail: [info@pilz.com](mailto:info@pilz.com), Internet: [www.pilz.com](http://www.pilz.com)

**PILZ**  
THE SPIRIT OF SAFETY

CECE®, CHRE®, CMSE®, InduraNET p®, Leansafe®, Master of Safety®, Master of Security®, PAS4000®, PAScale®, PASconfig®, Pilz®, PTT®, PLID®, PMCprimo®, PMCprotego®, PMCTendo®, PMD®, PMJ®, PNOZ®, PRBM®, PRGM®, PRCM®, PSS®, PVIS®, SafetyBUS p®, SafetyNET p®, THE SPIRIT OF SAFETY® are registered and protected trademarks of Pilz GmbH & Co. KG in some countries. We would point out that product features may vary from the details stated in this document, depending on the status at the time of publication and the scope of the equipment. We accept no responsibility for the validity, accuracy and entirety of the text and graphics presented in this information. Please contact our Technical Support if you have any questions.

21975-EN-06, 2021-12 Printed in Germany  
© Pilz GmbH & Co. KG, 2019