

▶ PSSu E F 4DI(-T)(-R)

PILZ

THE SPIRIT OF SAFETY

Operating Manual-21310-EN-10

- Decentralised system PSSuniversal I/O



This document is the original document.

Where unavoidable, for reasons of readability, the masculine form has been selected when formulating this document. We do assure you that all persons are regarded without discrimination and on an equal basis.

All rights to this documentation are reserved by Pilz GmbH & Co. KG. Copies may be made for the user's internal purposes. Suggestions and comments for improving this documentation will be gratefully received.

Pilz®, PIT®, PMI®, PNOZ®, Primo®, PSEN®, PSS®, PVIS®, SafetyBUS p®, SafetyEYE®, SafetyNET p®, the spirit of safety® are registered and protected trademarks of Pilz GmbH & Co. KG in some countries.



SD means Secure Digital

1	Introduction	5
1.1	Validity of documentation	5
1.1.1	Retaining the documentation	5
1.1.2	Terminology: System environment A and B	5
1.2	Definition of symbols	6
2	Overview	7
2.1	Module structure	7
2.2	Module features	7
2.3	Front view	8
3	Safety	10
3.1	Intended use	10
3.2	Safety regulations	12
3.2.1	Use of qualified personnel	12
3.2.2	Warranty and liability	12
3.2.3	Disposal	12
4	Function description	13
4.1	Block diagram	13
4.2	Functions	13
4.3	Integrated protection mechanisms	14
4.4	Reaction times	14
4.5	Configuration	15
4.5.1	PSSu assignment in system environment A	15
4.5.1.1	Addresses in the process image	15
4.5.2	PSSu assignment in system environment B	15
5	Installation	16
5.1	General installation guidelines	16
5.1.1	Dimensions	16
5.2	Installing the base module	17
5.3	Inserting and removing an electronic module	18
5.3.1	Inserting an electronic module	19
5.3.2	Removing an electronic module	20
5.3.3	Changing an electronic module during operation	20
6	Wiring	21
6.1	General wiring guidelines	21
6.1.1	Mechanical connection of the base modules	21
6.2	Terminal configuration	23
6.3	Connecting the module	25
7	Operation	28
7.1	Messages	28
7.2	Display elements	29
7.2.1	Display elements for module diagnostics	29
7.2.2	Display elements for input status	29

8	Technical details	30
8.1	Safety characteristic data.....	34
9	Supplementary data	35
9.1	Permitted operating height.....	35
10	Order reference	36
10.1	Product.....	36
10.2	Accessories.....	36
11	EC declaration of conformity for PSSu E F 4DI and PSSu E F 4DI-T	37
12	UKCA-Declaration of Conformity for PSSu E F 4DI and PSSu E F 4DI-T	38

1 Introduction

1.1 Validity of documentation

This documentation is valid for the product types PSSu E F 4DI, PSSu E F 4DI-T and PSSu E F 4DI-R. It is valid until new documentation is published.

This operating manual explains the function and operation, describes the installation and provides guidelines on how to connect the product.

1.1.1 Retaining the documentation

This documentation is intended for instruction and should be retained for future reference.

1.1.2 Terminology: System environment A and B

The PSSu system can be used in two different system environments. The module's application area is described in the chapter "Intended Use" of the manual.

The distinction is made between

- ▶ PSSu in system environment A
- ▶ PSSu in system environment B

The distinction is based on the application area of the PSSu system.

PSSu in system environment A may be used in the

- ▶ Decentralised system PSSu I/O
- ▶ **Not** in the automation system PSS 4000

PSSu in system environment B may be used in the

- ▶ Automation system PSS 4000, e.g. with
 - Decentralised system PSSu I/O with SafetyNET p
 - Control system PSSu PLC
 - Control system PSSu multi

1.2 Definition of symbols

Information that is particularly important is identified as follows:



DANGER!

This warning must be heeded! It warns of a hazardous situation that poses an immediate threat of serious injury and death and indicates preventive measures that can be taken.



WARNING!

This warning must be heeded! It warns of a hazardous situation that could lead to serious injury and death and indicates preventive measures that can be taken.



CAUTION!

This refers to a hazard that can lead to a less serious or minor injury plus material damage, and also provides information on preventive measures that can be taken.



NOTICE

This describes a situation in which the product or devices could be damaged and also provides information on preventive measures that can be taken. It also highlights areas within the text that are of particular importance.



INFORMATION

This gives advice on applications and provides information on special features.

2 Overview

2.1 Module structure

A module consists of

- ▶ Electronic module and
- ▶ Base module with
 - Screw terminals or
 - Cage clamp terminals

The base modules are the carrier units for the electronic modules and are used to connect the field wiring. The electronic modules are inserted on to the base modules and determine the module's function.

Details of the base modules that can be used are available in the chapter entitled “Intended Use”.

2.2 Module features

The product has the following features:

- ▶ 4 digital inputs
- ▶ 2 test pulse outputs, with the option to configure them as:
 - Independent test pulse outputs that use different test pulses (periphery supply)
 - Outputs with constant voltage (periphery supply)
- ▶ LEDs for:
 - Switch status of each input
 - Module error
- ▶ For failsafe applications in system environment A and B
- ▶ T-type:
 - PSSu E F 4DI-T: for increased environmental requirements
- ▶ R-type:
 - PSSu E F 4DI-R: for railway applications

2.3 Front view

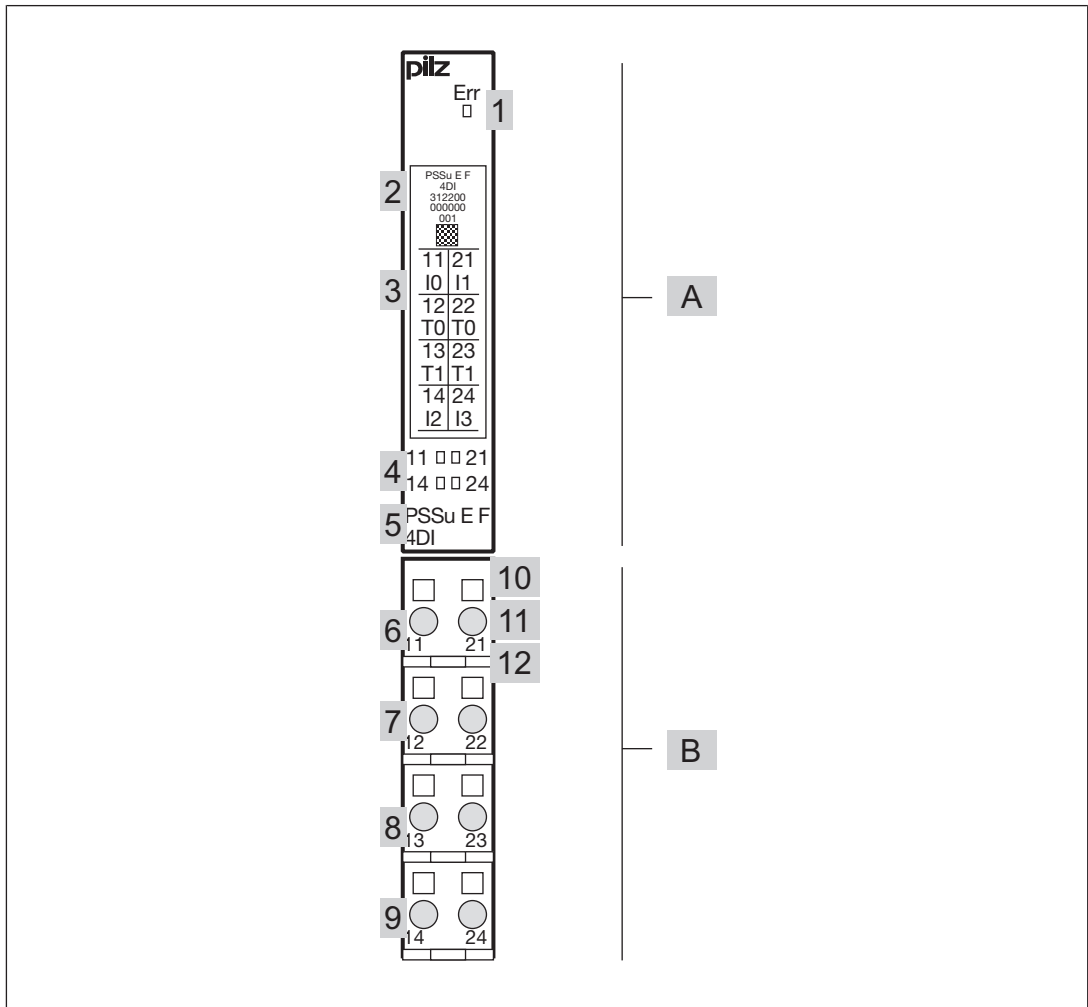

Legend:

- ▶ A: Electronic module
- ▶ B: Base module
- ▶ 1: LED for module diagnostics
- ▶ 2: Labelling strip with:
 - Name of electronic module
 - Order Number
 - Serial number
 - Hardware version number
 - 2D code
- ▶ 3: Labelling strip for the terminal configuration on the base module
- ▶ 4: Status LEDs
- ▶ 5: Name of electronic module
- ▶ 6: Connection level 1
- ▶ 7: Connection level 2
- ▶ 8: Connection level 3

- ▶ 9: Connection level 4
- ▶ 10: Square mounting holes (connection levels 1, 2, 3 and 4)
 - With screw to loosen/tighten the screw terminal on base modules with screw terminals
 - With mechanism to operate the cage clamp on base modules with cage clamp terminals
- ▶ 11: Round connection holes (connection levels 1, 2, 3 and 4) for connecting the signal lines
- ▶ 12: Mounting slot for colour marker to label the connection level (connection levels 1, 2, 3 and 4)

3 Safety

3.1 Intended use



INFORMATION

If the module name is not explicitly named, the details apply to all the variants of the module.

Use in a PSSu system

The module may be used in a PSSu system in system environment A and B.

The head module establishes in what system environment a PSSu system can be used.

▶ System environment A

A PSSu system in system environment A is a decentralised system PSSu I/O with a field-bus, but without SafetyNET p interface. The automation system PSS 4000 does **not** belong to the system environment A.

▶ System environment

A PSSu system in system environment B is a PSSu system in the h automation system PSS 4000. The PSSu system can belong to one of the following performance classes:

- Decentralised system PSSu I/O (with SafetyNET p)
- Control system PSSu PLC
- Control system PSSu multi

Failsafe applications

The module may be used for failsafe applications.

The module meets the requirements of EN IEC 61508 up to SIL 3.

Failsafe inputs

The module has failsafe inputs.

It provides type 1 failsafe inputs in accordance with IEC 61131-2.

Particular application areas

▶ Increased environmental requirements

The module PSSu E F 4DI-T is suitable for use where there are increased environmental requirements (see [Technical details](#) [ 30]).

▶ Lift applications

The modules PSSu E F 4DI and PSSu E F 4DI-T can be used as a PESSRAL (programmable electronic system in safety-related applications for lifts) in accordance with the Lifts Directive 2014/33/EU. The modules meet the requirements in accordance with EN 81-20, EN 81-50 for passenger and goods lifts the requirements in accordance with EN 115-1 for escalators and moving walks.

The module/the safety controller should be installed in a protected environment. Example: Protected inside space or control cabinet with protection class and corresponding air conditioning specified in [Technical details \[30\]](#).

► **Railway applications**

The module PSSu E F 4DI-R is **only** intended and certified for use in railway applications (CENELEC) where there are increased environmental requirements (see [Technical details \[30\]](#)). Any other use is **not** permitted.

Permitted operating height

With reference to the standard IEC 61131-2 the values stated in the technical details for ambient temperature are reduced at heights >2000 m operating height above sea level (see [Supplementary data \[35\]](#)).

EMC-compliant installation

Intended use includes making the electrical installation EMC-compliant. Please refer to the guidelines stated in the "PSSuniversal Installation Manual". The module is intended for use in an industrial environment. Interference may occur if used within a domestic environment.

Improper use

The following is deemed improper use in particular

- Any component, technical or electrical modification to the module,
- Use of the module outside the areas described in this operating manual,
- Any use of the module that is not in accordance with the technical details.

Software tools

The modules PSSu E F 4DI and PSSu E F 4DI-T are supported by:

- PSSuniversal Configurator and PSSuniversal Assistant from Version 1.4.0
- PAS4000 from Version 1.1.1

The module PSSu E F 4DI-R is supported by:

- PAS4000 from Version 1.5.0



INFORMATION

We recommend that you always use the latest version of the software tool (download from www.pilz.com).

Base modules

The PSSu E F 4DI module may be used in conjunction with the following base modules:

- PSSu BP 1/8 S
- PSSu BP 1/8 C
- PSSu BP 1/12 S
- PSSu BP 1/12 C
- PSSu BP-C1 1/12 S
- PSSu BP-C1 1/12 C

The PSSu E F 4DI-T and PSSu E F 4DI-R modules may be used in conjunction with the following base modules:

- ▶ PSSu BP 1/8 S-T
- ▶ PSSu BP 1/8 C-T
- ▶ PSSu BP 1/12 S-T
- ▶ PSSu BP 1/12 C-T
- ▶ PSSu BP-C1 1/12 S-T
- ▶ PSSu BP-C1 1/12 C-T

3.2 Safety regulations

3.2.1 Use of qualified personnel

The products may only be assembled, installed, programmed, commissioned, operated, maintained and decommissioned by persons who are competent to do so.

A competent person is a qualified and knowledgeable person who, because of their training, experience and current professional activity, has the specialist knowledge required. In order to inspect, assess and handle products, devices, systems, plant and machinery, this person must be familiar with the state of the art and the applicable national, European and international laws, directives and standards.

It is the company's responsibility only to employ personnel who

- ▶ Are familiar with the basic regulations concerning health and safety / accident prevention,
- ▶ Have read and understood the information provided in the section entitled Safety
- ▶ Have a good knowledge of the generic and specialist standards applicable to the specific application.

3.2.2 Warranty and liability

All claims to warranty and liability will be rendered invalid if

- ▶ The product was used contrary to the purpose for which it is intended,
- ▶ Damage can be attributed to not having followed the guidelines in the manual,
- ▶ Operating personnel are not suitably qualified,
- ▶ Any type of modification has been made (e.g. exchanging components on the PCB boards, soldering work etc.).

3.2.3 Disposal

- ▶ In safety-related applications, please comply with the mission time T_M in the safety-related characteristic data.
- ▶ When decommissioning, please comply with local regulations regarding the disposal of electronic devices (e.g. Electrical and Electronic Equipment Act).

4 Function description

4.1 Block diagram

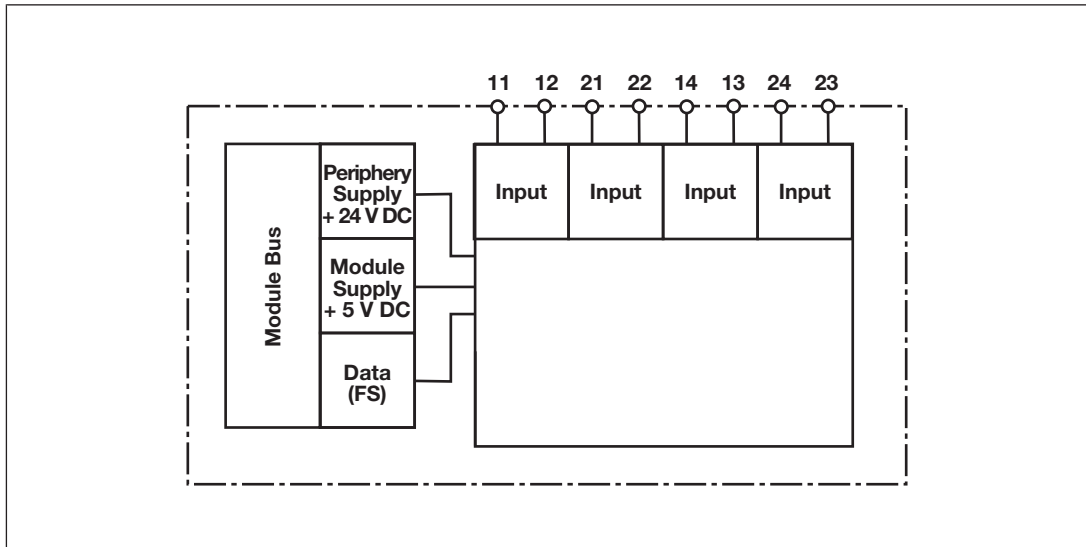

4.2 Functions

Module supply

- ▶ The module supply provides the module with voltage.

Periphery supply

- ▶ The module switches the periphery supply from the module bus to the base module terminals.
- ▶ The periphery supply is used to supply or provide test pulses to the input devices.

Inputs

- ▶ The input status is signalled to the head module via the module bus.
- ▶ Test pulses can be used to check the inputs for shorts across contacts and correct functionality.
- ▶ The inputs have input filters.

Test pulse outputs

- ▶ 2 test pulse outputs that use different test pulses (test pulse 0, test pulse 1)
- ▶ Short circuit-proof
- ▶ Current limitation
- ▶ Test pulses can be switched on or off.
- ▶ Test pulses are switched on in the default setting.
- ▶ When test pulses are switched off, the periphery supply is constantly available at the outputs.

Detection of shorts across contacts

- ▶ The test pulses are used to detect shorts between inputs. Shorts between inputs are detected when
 - the test pulses are different (test pulse 0, test pulse 1) or when

- the test pulses originate from other modules on a PSSu system.
- ▶ Shorts between inputs of the same module with the same test pulses will not be detected.

4.3 **Integrated protection mechanisms**

When the PSSu E F PS1(-T) or PSSu E F PS2(-T)(-R) is used to supply the system, the module supply is buffered for 20 ms if the supply voltage is interrupted.

- ▶ Test pulse signals are always buffered for 20 ms.

The module provides the following diagnostic data:

- ▶ Start-up error
- ▶ Configuration error
- ▶ FS communication error
- ▶ Bus termination error
- ▶ Temperature error: Too warm
- ▶ Test pulse error
- ▶ Input error

4.4 **Reaction times**

Information on the reaction times of the inputs can be found in the "PSSuniversal" System Description and the System Description "Automation system PSS 4000".

4.5 Configuration

4.5.1 PSSu assignment in system environment A

Functions for the FS inputs of a PSSu are defined in the PSSuniversal Configurator on the PSS WIN-PRO system software:

- ▶ Read access through the standard bus system (configured per module):
“R” configuration
- ▶ Allocation of a test pulse output to an input (configured per input)
- ▶ Optimisation of ST process image by combining adjacent bits of the same type.
“*” configuration



INFORMATION

The PSSuniversal Configurator on the PSS WIN-PRO system software must be used to define the I/O-Groups to which FS inputs and outputs belong (SafetyBUS p). The PSSu can be divided into sections A and B for this purpose. All the FS inputs on a PSSu always belong to section B.

Section A and section B on a PSSu may belong to different I/O-Groups.

Further information on configuration is available in the PSSuniversal Configurator's online help.

4.5.1.1 Addresses in the process image

The module occupies 4 consecutive bit addresses in the process image. The process image in which the inputs are shown depends on the configuration.

Configuration	SafetyBUS p	Standard bus system	
		ST-PII	ST-PIO
	FS-PII	ST-PII	ST-PIO
None	4 Bit	---	---
Read ST (“R”)	(e. g.: 32.00 ... 32.03)	4 Bit	---

4.5.2 PSSu assignment in system environment B

Data access is via pre-defined I/O data types:

I/O data name	I/O data type	I/O data element	Meaning
I0(11), I1(21), I2(14), I3(24)	FS_I_DI	Data: SAFEBOOL	Input data I0 ... I3

5 Installation

5.1 General installation guidelines

Please also refer to the PSSuniversal Installation Manual.



NOTICE

Damage due to electrostatic discharge!

Electrostatic discharge can damage components. Ensure against discharge before touching the product, e.g. by touching an earthed, conductive surface or by wearing an earthed armband.

5.1.1 Dimensions

Base modules with four connection levels:

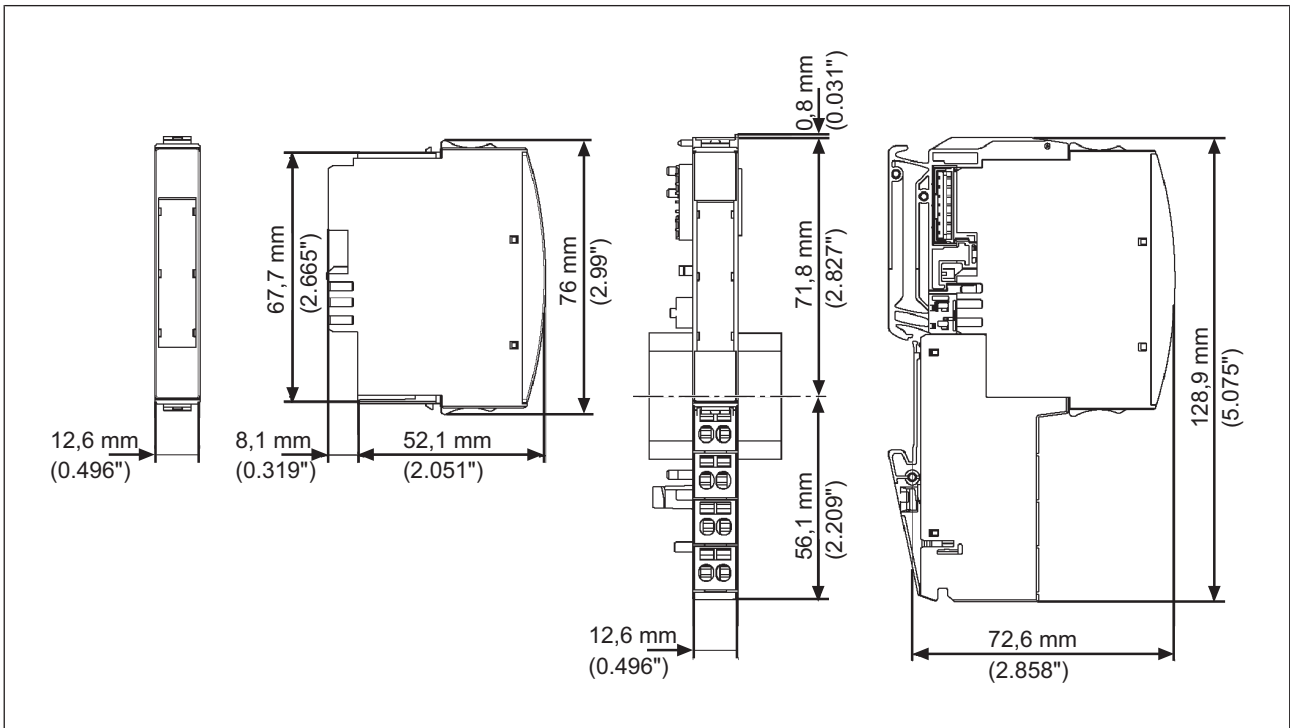

Base modules with six connection levels:

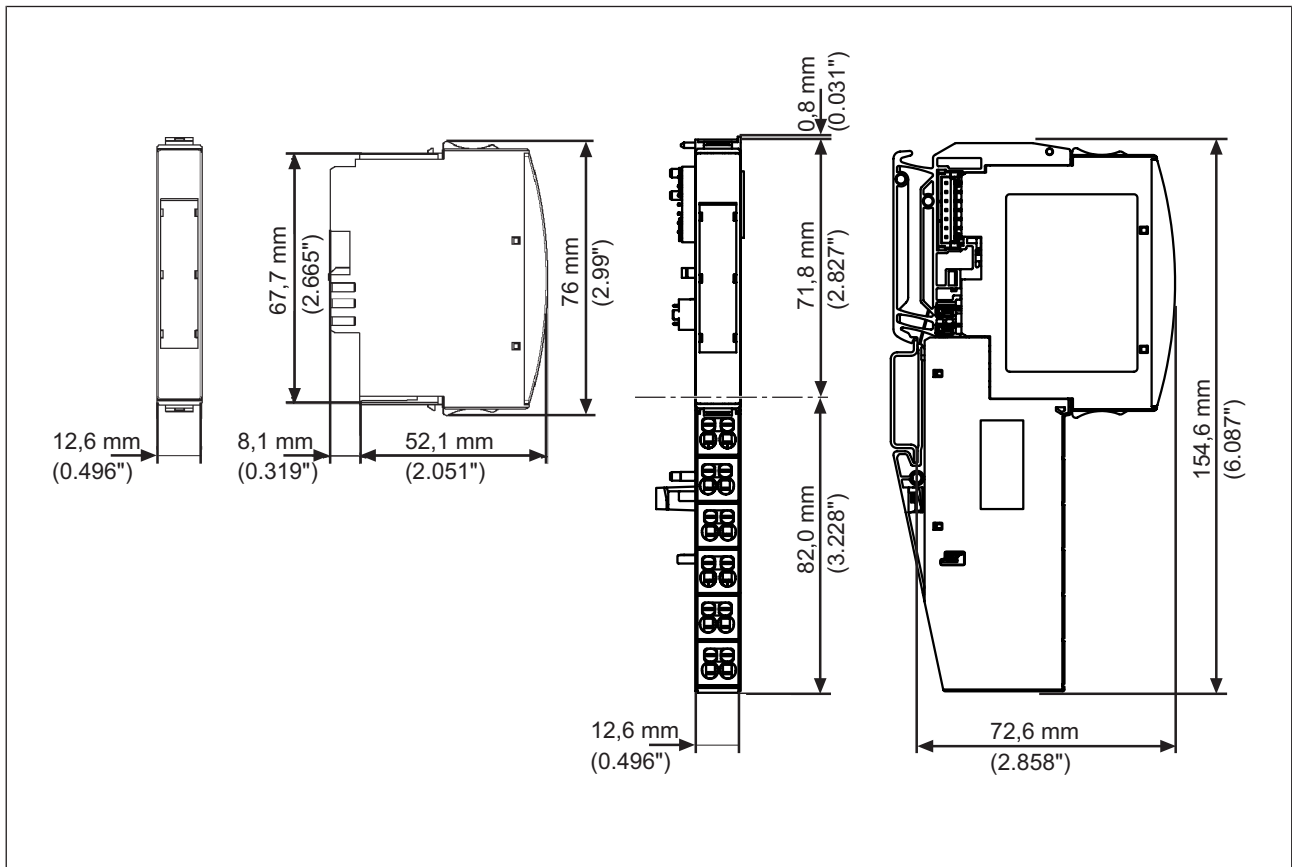

5.2 Installing the base module

Prerequisite:

- ▶ The head module must be installed.
- ▶ If the head module does not have an integrated power supply, a supply voltage module must be installed to the right of the head module.

Please note:

- ▶ For mechanical reasons it is not possible to mix base modules with screw terminals and base modules with cage clamp terminals.
- ▶ All contacts should be protected from contamination.
- ▶ The mechanics of the base modules are designed for 50 plug in/out cycles.

Procedure:

- ▶ We recommend that you wire up the base modules before inserting the electronic modules.
- ▶ Slot the groove on the base module on to the mounting rail from below [1].
- ▶ Push the base module back [2] until you hear it lock into position.
- ▶ On the mounting rail, slide the base module to the left until you hear the two lateral mounting hooks on the adjacent module lock into position [3].

Schematic representation:

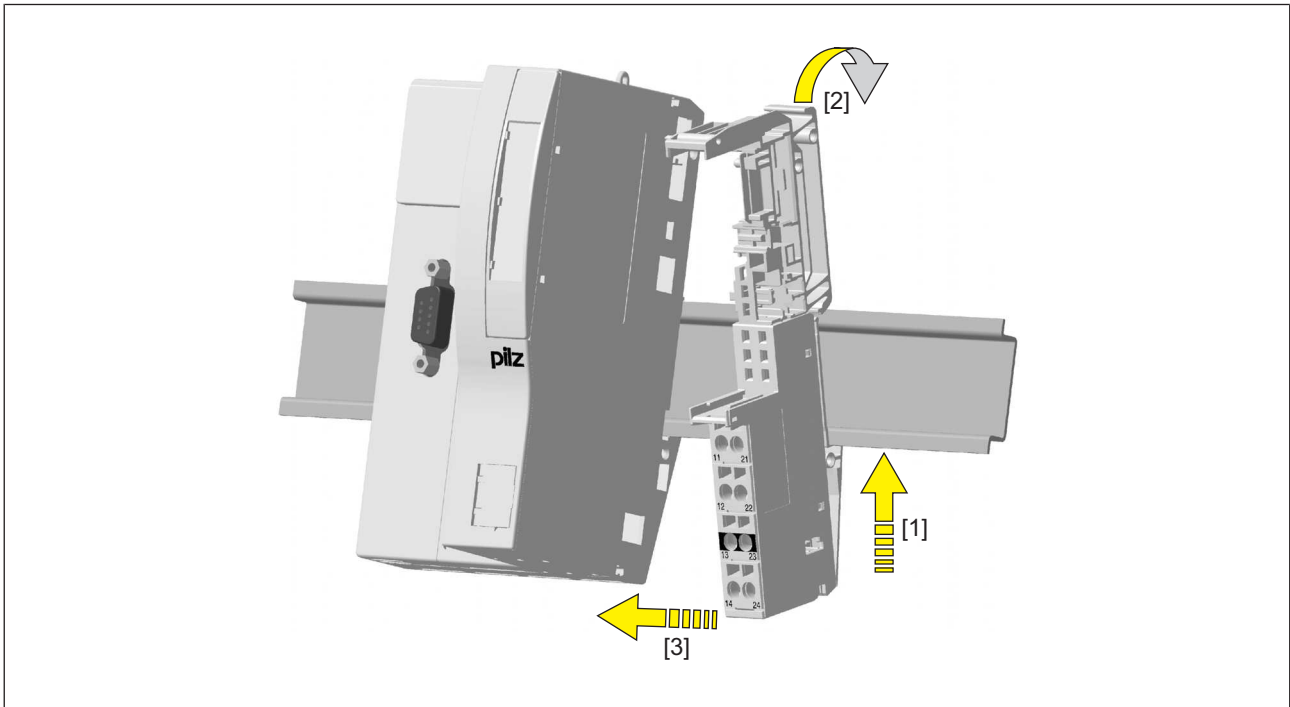

5.3 Inserting and removing an electronic module

Please note:

- ▶ Only insert on to base modules that are already installed.
- ▶ Preferably these base modules should be ready wired.
- ▶ Electronic modules with outputs may only be inserted and removed when the load is switched off. Unforeseeable error reactions may be triggered if modules are inserted and removed under load.
- ▶ When an electronic module is plugged into a base module for the first time, one part of the coding element remains on the electronic module, while its counterpart is fixed on to the base module. This is how the base module is coded.
- ▶ The mechanics of the electronic modules are designed for 50 plug in/out cycles.

5.3.1 Inserting an electronic module

Procedure:

- ▶ The electronic module must audibly lock into position [1].
- ▶ Mark the electronic module using the labelling strips [2].

Schematic representation:

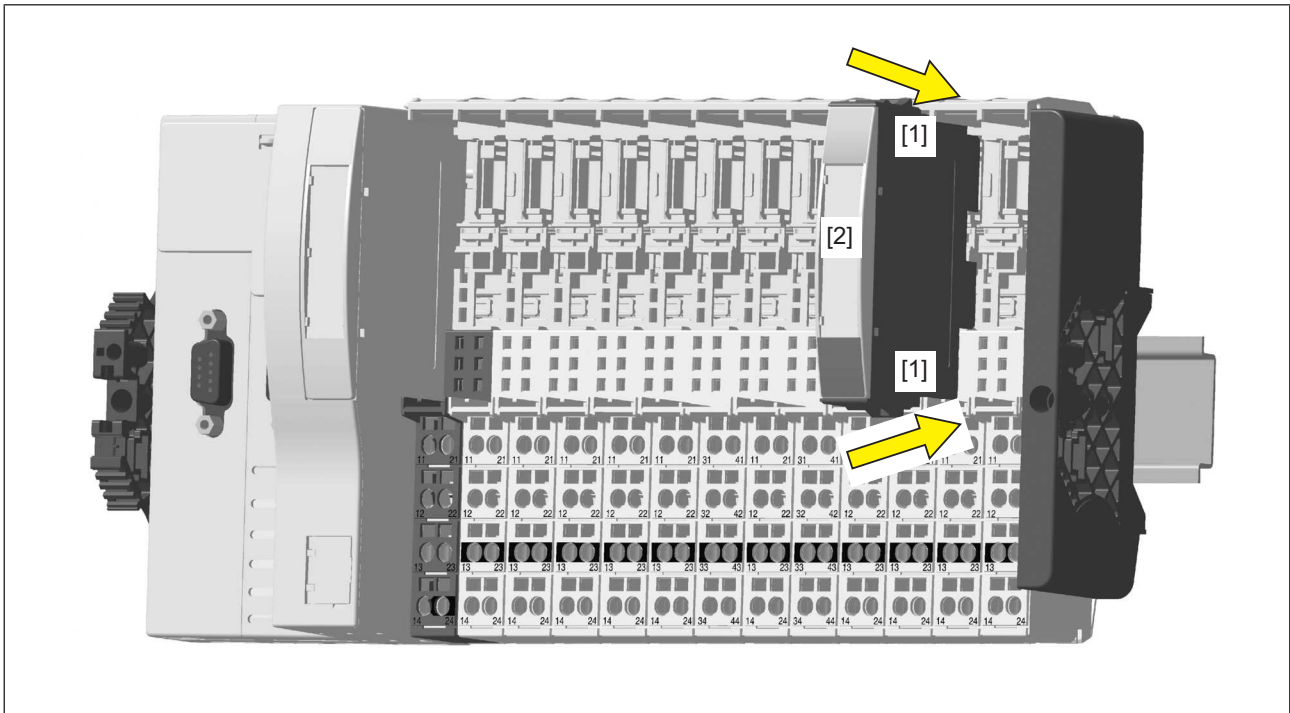

5.3.2 Removing an electronic module

Procedure:

- ▶ Press the locking mechanisms [1] together simultaneously.
- ▶ Pull out the electronic module [2].

Schematic representation:

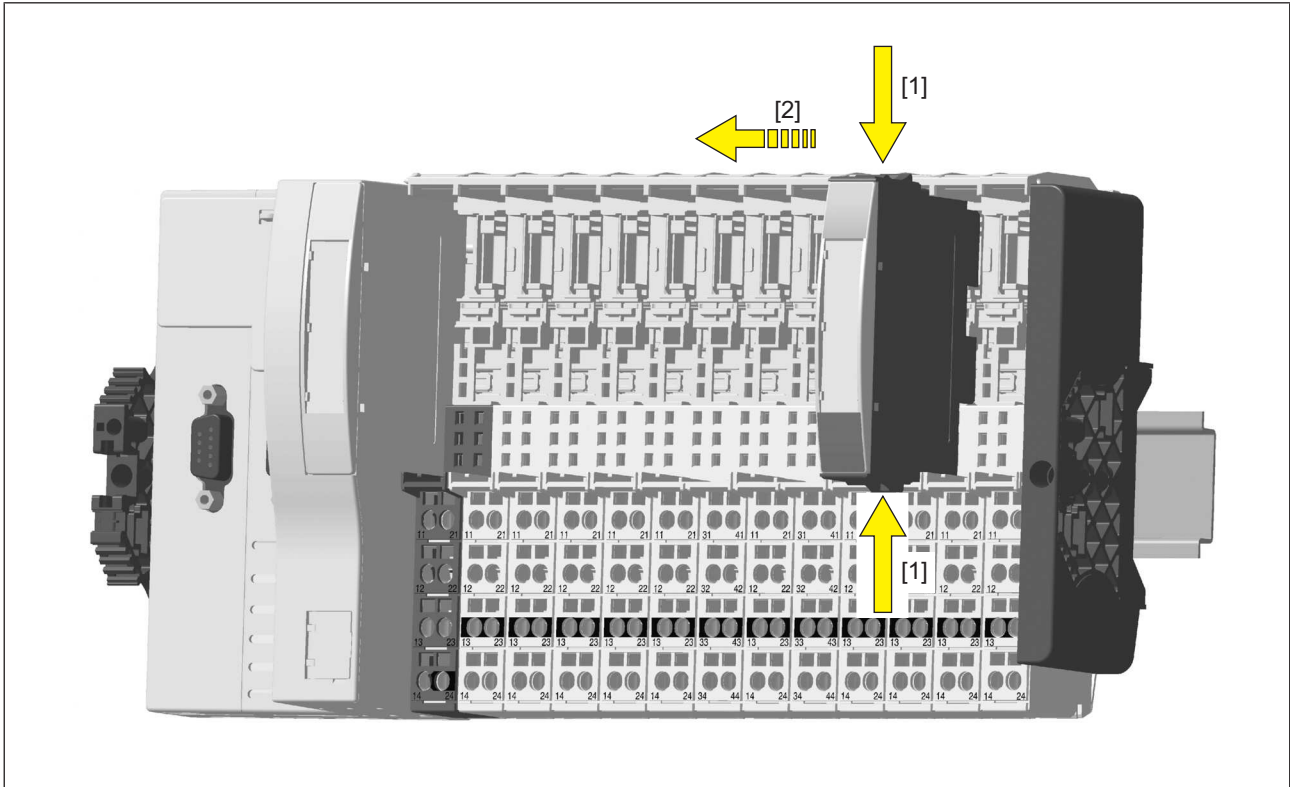

5.3.3 Changing an electronic module during operation

It is possible to change an electronic module during operation. The configuration data is retained when a module is changed.

Effects:

- ▶ System environment A:
 - In the event of a potential FS communication error, the FS section of the PSSu system and all relevant I/O-Groups (SafetyBUS p) switch to a STOP condition.
- ▶ System environment B:
 - All FS hardware outputs on the PSSu system switch to a safe condition.
 - The substitute values are used for the modules' FS outputs, with Valid Bits = FALSE.



CAUTION!

Sparking can cause interference and errors!

Only change the module when the load is switched off!

6 Wiring

6.1 General wiring guidelines

Please note:

- ▶ Appropriate wiring must be used to exclude short circuits between the test pulse outputs and the corresponding input!
- ▶ Appropriate wiring must be used to exclude short circuits between the inputs or to a supply line!
- ▶ The cable runs for the test pulses may be max. 200 m.
- ▶ Signal lines do not have to be shielded.
- ▶ Use copper wiring.

6.1.1 Mechanical connection of the base modules

Procedure:

- ▶ Use a flat blade screwdriver (DIN 5264-A)!

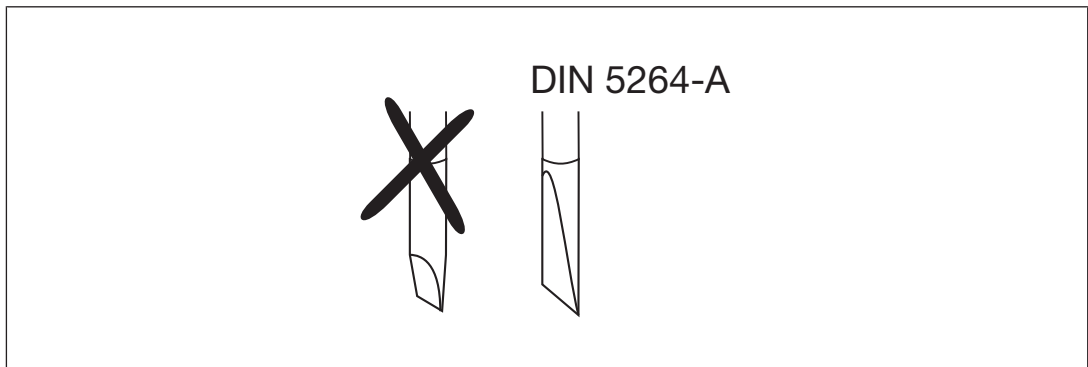

- ▶ Strip the wire back 8 mm.
- ▶ If necessary, label the connection level with a colour marker [3].
- ▶ Base module with screw terminals:
 - Use a screwdriver to loosen the screw on the screw terminal [1]
 - Insert the stripped cable into the round fixing hole [2], as far as it will go.
 - Tighten up the screw on the screw terminal.
 - Check that the cable is firmly seated.
- ▶ Base module with cage clamp terminals:
 - Insert the screwdriver [4] into the square hole [1].
 - Insert the stripped cable into the round fixing hole [2], as far as it will go [5].
 - Pull out the screwdriver [6].
 - Check that the cable is firmly seated.

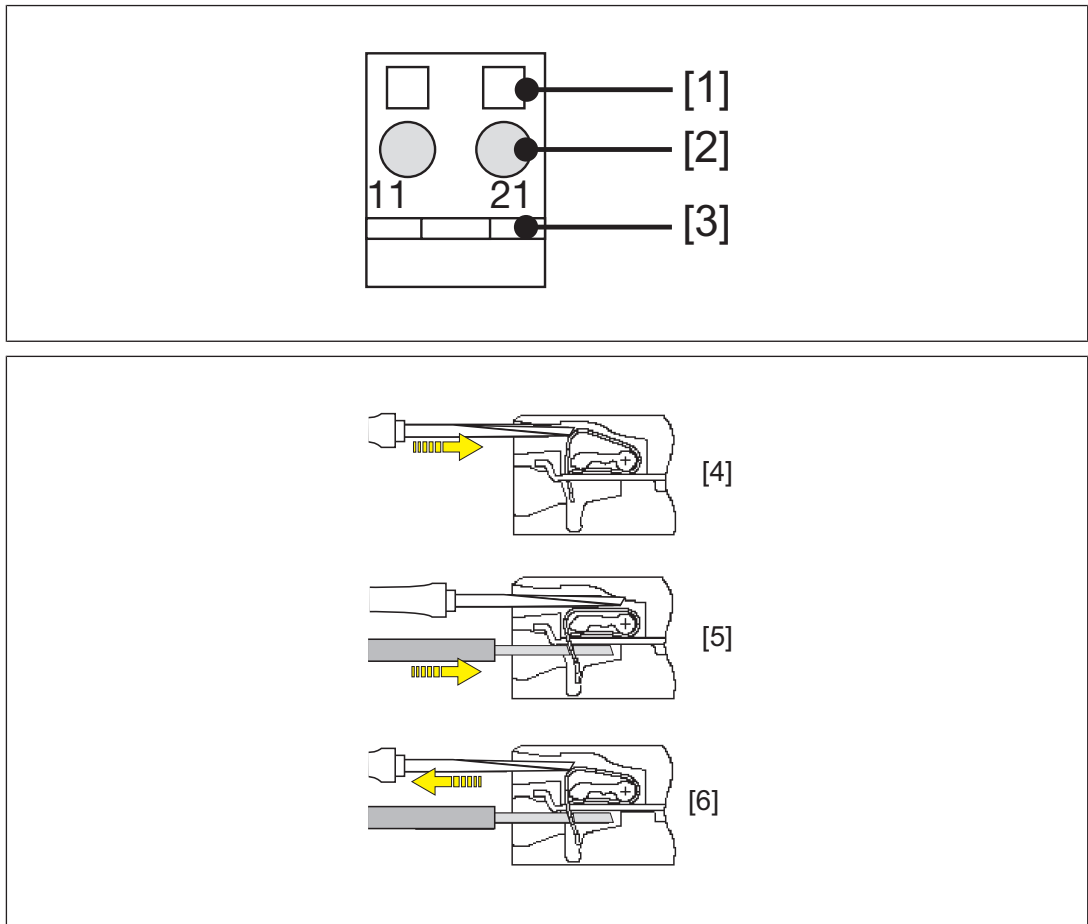

Please note:

- ▶ The minimum cable cross section for field connection terminals on the base modules is 0.14 mm² (AWG26).
- ▶ The maximum cable cross section for field connection terminals is:
 - Digital inputs: 1.5 mm² (AWG16)
 - Digital outputs: 2.0 mm² (AWG14)
 - Inputs/outputs on the counter modules: 1.5 mm² (AWG16)
 - Analogue inputs/outputs: 1.5 mm² (AWG16)
 - Communication cables: 1.5 mm² (AWG16)
 - Test pulse outputs: 1.5 mm² (AWG16)
 - Power supply: 2.5 mm² (AWG12)
 - Functional earth: 2.5 mm² (AWG12)
- ▶ On base modules with screw terminals:
 - If you use a multi-strand cable to connect the I/Os, it is recommended that you use ferrules conforming to Parts 1 and 2 of DIN 46228, 0.14 ... 1.5 mm², Form A or C, although this is not essential. To crimp the ferrules you can use crimp pliers (crimp form A or C) conforming to EN 60947-1, such as the PZ 1.5 or PZ 6.5 from Weidmüller, for example.
 - Maximum torque setting: 0.8 Nm

► Use copper wiring.

6.2 Terminal configuration

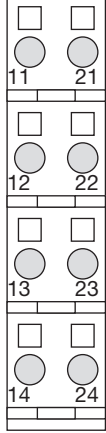
Base module	Terminal configuration	
<p>Screw terminals: PSSu BP 1/8 S PSSu BP 1/8 S-T</p> <p>Cage clamp terminals: PSSu BP 1/8 C PSSu BP 1/8 C-T</p>	<p>Without C-rail:</p> <p>11: Input I0</p> <p>21: Input I1</p> <p>12 -22: Test pulse output T0 or +24 V output (periphery supply, 12-22 linked within the base module)</p> <p>13 -23: Test pulse output T1 or +24 V output (periphery supply, 13-23 linked within the base module)</p> <p>14: Input I2</p> <p>24: Input I3</p>	

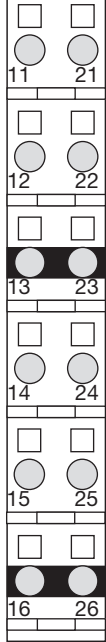
Base module	Terminal configuration	
<p>Screw terminals: PSSu BP-C1 1/12 S PSSu BP-C1 1/12 S-T</p> <p>Cage clamp terminals: PSSu BP-C 1/12 C PSSu BP-C 1/12 C-T</p>	<p>With C-rail:</p> <p>11: Input I0</p> <p>21: Input I1</p> <p>12 -22: Test pulse output T0 or +24 V output (periphery supply, 12-22 linked within the base module)</p> <p>13 -23: C-rail supply (13-23-16-26 linked within the base module)</p> <p>14: Input I2</p> <p>24: Input I3</p> <p>15 -25: Test pulse output T1 or +24 V output (periphery supply, 15-25 linked within the base module)</p> <p>16 -26: C-rail supply (13-23-16-26 linked within the base module)</p>	

6.3 Connecting the module

Input circuit	Single-channel input device	Dual-channel input device
Without test pulses (unchecked)		
Without test pulses (unchecked) Input device with homogeneous channels		
Without test pulses (unchecked) Input device with diverse channels		

Input circuit	Single-channel input device	Dual-channel input device
With test pulses (checked)		
With test pulses (checked) Input device with homogeneous channels		
With test pulses (checked) Input device with homogeneous channels		

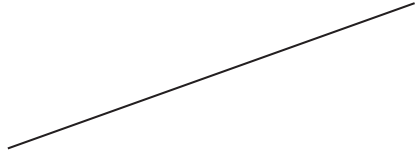
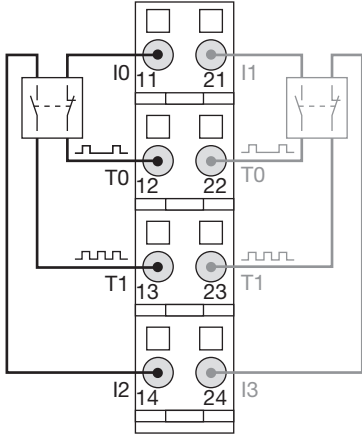
Input circuit	Single-channel input device	Dual-channel input device
<p>With test pulses (checked) Input device with diverse channels</p>		

7 Operation

7.1 Messages

A module error is displayed via the "Err" LED (see section entitled "Display elements"). It is signalled to the head module and then entered in the

- ▶ Error stack, with PSSu in system environment A
- ▶ Diagnostic log, with PSSu in system environment B.



of the head module.

The module can detect the following errors:

Module error	Explanation	Remedy
Start-up error	Error as the PSSu system starts up	Change faulty module.
Configuration error	Incorrect module type configured.	The configured hardware registry does not match the actual hardware registry.
FS communication error	Error during FS communication	Change faulty module.
Bus termination error	There is no terminating plate or there is a bad contact with the module bus.	Install a terminating plate with integrated end bracket or insert the base modules together correctly.
Temperature error: too warm	Ambient temperature too high: Error stack entry/diagnostic log entry	Ensure there is sufficient ventilation in the control cabinet or prevent overload.
Error in the feedback loop	FS input detects an error in the feedback loop or FS input is defective.	Check FS input, check the configuration of the feedback loop, check the signals, or check the wiring and contacts.
Input error	Error during the cyclical input test. Possible cause: Input defective.	Change faulty module.
Test pulse error	Possible causes: Short circuit between a test pulse and a supply voltage, or a defective module.	Rectify the short circuit or change the faulty module.



7.2 Display elements

Legend

-  LED on
-  LED off



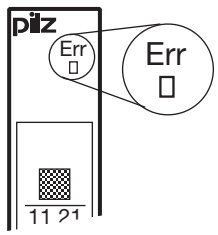



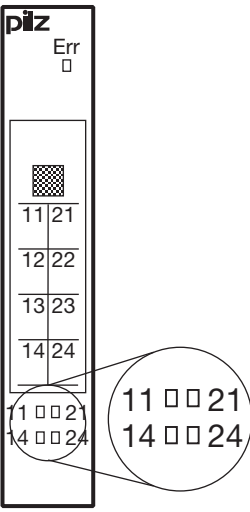

7.2.1 Display elements for module diagnostics

The module has an LED for displaying module errors ("Err" LED).

	LED			Meaning
	Name	Colour	Status	
	Err	---		No error
	Red		Module error	

7.2.2 Display elements for input status

Each input is assigned an LED for displaying the input status (LEDs "11", "21", "14" and "24").

	LED			Meaning		
	Designation	Colour	Status	Signal	Input	Terminal
	11	---		0 signal	I0 (Input 1)	11
		Green		1 signal		
	21	---		0 signal	I1 (Input 2)	14
		Green		1 signal		
	14	---		0 signal	I2 (Input 3)	21
		Green		1 signal		
	24	---		0 signal	I3 (Input 4)	24
		Green		1 signal		

8 Technical details

General	312200	314200	315200
Certifications	CE, EAC, KOSHA, TÜV, UKCA, cULus Listed	CE, EAC, KOSHA, TÜV, UKCA, cULus Listed	CE, EAC, TÜV, UKCA
Application range	Failsafe	Failsafe	Failsafe
Module's device code	0A00h	0A00h	0A00h
Number of FS input bits	4	4	4
Application in system environment A			
from FS firmware version, other head modules	4	4	–
from FS firmware version PSSu H F PN	1	1	–
Application in system environment B			
from FS firmware version, head modules	1.0.0	1.0.0	1.5.0
Electrical data	312200	314200	315200
Internal supply voltage (module supply)			
Module's power consumption	0,12 W	0,12 W	0,12 W
Periphery's supply voltage (periphery supply)			
Voltage range	16,8 - 30 V	16,8 - 30 V	16,8 - 30 V
Module's current consumption with no load	8 mA	8 mA	8 mA
Module's power consumption with no load	0,19 W	0,19 W	0,19 W
Max. power dissipation of module	1,5 W	1,5 W	1,5 W
Inputs	312200	314200	315200
Quantity	4	4	4
Voltage at inputs	24 V DC	24 V DC	24 V DC
Input current at rated voltage	6 mA	6 mA	6 mA
Input current range	2,6 - 7,8 mA	2,6 - 7,8 mA	2,6 - 7,8 mA
Min. threshold voltage when signal changes from "1" to "0"	9 V	9 V	9 V
Max. threshold voltage when signal changes from "0" to "1"	10 V	10 V	10 V
Max. processing time of input when signal changes from "1" to "0"	1 ms	1 ms	1 ms

Inputs	312200	314200	315200
Max. processing time of input when signal changes from "0" to "1"	1 ms	1 ms	1 ms
Min. processing time of input when signal changes from "1" to "0"	0,5 ms	0,5 ms	0,5 ms
Min. processing time of input when signal changes from "0" to "1"	0,5 ms	0,5 ms	0,5 ms
Potential isolation between input and internal module bus voltage	Yes	Yes	Yes
Test pulse outputs	312200	314200	315200
Number of test pulse outputs	2	2	2
Voltage, test pulse outputs	24 V DC	24 V DC	24 V DC
Short circuit-proof	Yes	Yes	Yes
Number of outputs that can be configured as test pulses	2	2	2
Max. output current at "1" signal	0,25 A	0,25 A	0,25 A
Max. cable length between test pulse output and input	200 m	200 m	200 m
Standard for voltage interruptions	EN 61131-2	EN 61131-2	–
Environmental data	312200	314200	315200
Application site			
in accordance with the standard	–	–	EN 50125-3
Application site	–	–	Track area (1 m - 3 m)
in accordance with the standard	–	–	EN 61373
Application site	–	–	Category 1, Class A + B
Climatic suitability	EN 60068-2-1, EN 60068-2-14, EN 60068-2-2, EN 60068-2-30, EN 60068-2-78	EN 60068-2-1, EN 60068-2-14, EN 60068-2-2, EN 60068-2-30, EN 60068-2-78	EN 50125-1, EN 50125-3, EN 50155, EN 60068-2-1, EN 60068-2-14, EN 60068-2-2

Environmental data	312200	314200	315200
Ambient temperature			
in accordance with the standard	EN 60068-2-14	EN 60068-2-14	EN 50155
Temperature range	0 - 60 °C	-40 - 70 °C	-40 - 70 °C
in accordance with the standard	–	–	EN 50125-1
Temperature range	–	–	-40 ... +70 °C
in accordance with the standard	–	–	EN 50125-3
Temperature range	–	–	-40 ... +70 °C
Storage temperature			
in accordance with the standard	EN 60068-2-1/-2	EN 60068-2-1/-2	EN 60068-2-1/-2
Temperature range	-40 - 70 °C	-40 - 70 °C	-40 - 70 °C
Climatic suitability			
in accordance with the standard	EN 60068-2-78	EN 60068-2-78	EN 60068-2-78
Humidity	93 % r. h. at 40 °C	93 % r. h. at 40 °C	97 % r. h. at 40 °C
Condensation during operation	Not permitted	EN 60068-2-30, short-term	EN 50155, EN 60068-2-30, short-term
Max. operating height above SL	2000 m	5000 m	2000 m
Max. operating height above sea level in accordance with EN 81-1, EN 81-2 and EN 115-1	2000 m	2000 m	–
EMC	EN 12015, EN 12016, EN 61000-6-2, EN 61000-6-4, EN 61131-2 (Zone B)	EN 12015, EN 12016, EN 61000-6-2, EN 61000-6-4, EN 61131-2 (Zone B)	EN 50121-3-2, EN 50124-1, EN 61000-6-2, EN 61000-6-4
Vibration			
in accordance with the standard	EN 60068-2-6	EN 60068-2-6	–
Frequency	10 - 150 Hz	10 - 150 Hz	–
Acceleration	10 m/s²	10 m/s²	–
Broadband noise			
in accordance with the standard	–	EN 60068-2-64	–
Frequency	–	5 - 500 Hz	–
Acceleration	–	19 m/s² eff.	–
in accordance with the standard	–	–	EN 61373
Frequency	–	–	5 ... 150 Hz
Acceleration	–	–	7,9 m/s² eff.
in accordance with the standard	–	–	EN 50125-3
Frequency	–	–	5 - 2.000 Hz
Acceleration	–	–	2,3 m/s² eff.

Environmental data	312200	314200	315200
Shock stress			
in accordance with the standard	EN 60068-2-27	EN 60068-2-27	–
Number of shocks	6	6	–
Acceleration	150 m/s²	150 m/s²	–
Duration	11 ms	11 ms	–
in accordance with the standard	–	–	EN 50125-3
Number of shocks	–	–	6
Acceleration	–	–	20 m/s²
Duration	–	–	11 ms
in accordance with the standard	–	–	EN 61373
Number of shocks	–	–	6
Acceleration	–	–	50 m/s²
Duration	–	–	30 ms
Airgap creepage			
in accordance with the standard	EN 61131-2	EN 61131-2	–
Overvoltage category	II	II	–
Pollution degree	2	2	–
in accordance with the standard	–	–	EN 50124-1
Overvoltage category	–	–	OV2
Pollution degree	–	–	PD2
Protection type			
in accordance with the standard	EN 60529	EN 60529	–
Housing	IP20	IP20	–
Terminals	IP20	IP20	–
in accordance with the standard	–	–	EN 60529
Mounting area	–	–	IP51
Housing	–	–	IP20
Terminals	–	–	IP20
Mounting area (e.g. control cabinet)	IP54	IP54	–
Mechanical data	312200	314200	315200
Material			
Bottom	PC	PC	PC
Front	PC	PC	PC
Coding	PA	PA	PA
Mounting type	plug-in	plug-in	plug-in
Dimensions			
Height	76 mm	76 mm	76 mm
Width	12,6 mm	12,6 mm	12,6 mm
Depth	60,2 mm	60,2 mm	60,2 mm

Mechanical data	312200	314200	315200
Weight	35 g	37 g	36 g
Mechanical coding			
Type	D	D	D
Colour	Yellow	Yellow	Yellow

Where standards are undated, the 2022-01 latest editions shall apply.

8.1 Safety characteristic data



NOTICE

You must comply with the safety characteristic data in order to achieve the required safety level for your plant/machine.

Operating mode	EN ISO 13849-1: 2015 PL	EN ISO 13849-1: 2015 Category	EN IEC 62061 SIL CL/ maximum SIL	EN IEC 62061 PFH _D [1/h]	EN/IEC 61511 SIL	EN/IEC 61511 PFD	EN ISO 13849-1: 2015 T _M [year]
1-channel	PL d	Cat. 2	SIL CL 2	9,10E-09	SIL 2	7,25E-04	20
2-channel	PL e	Cat. 3	SIL CL 3	3,10E-09	SIL 3	1,85E-05	20
2-ch., pulsed	PL e	Cat. 4	SIL CL 3	3,10E-09	SIL 3	1,85E-05	20
1-ch., pulsed light barrier	PL e	Cat. 4	SIL CL 3	2,91E-09	SIL 3	7,52E-05	20

If the module is operated at an ambient temperature above 60° C, the values stated in the table for PFH_D and PFD will need to be doubled when a safety function is calculated.

All the units used within a safety function must be considered when calculating the safety characteristic data.



INFORMATION

A safety function's SIL/PL values are **not** identical to the SIL/PL values of the units that are used and may be different. We recommend that you use the PAScal software tool to calculate the safety function's SIL/PL values.

9 Supplementary data

9.1 Permitted operating height

The values stated in the technical details apply to the use of the device in operating heights up to max. 2000 m above SL. When used at higher levels, restrictions of the ambient temperature (standard IEC 61131-2) must be taken into account.

Operating height above SL [m]	Multiplication factors for the devices' ambient temperature
0 ... 2000	1.0
3000	0.9
4000	0.8
5000	0.7

10 Order reference

10.1 Product

Product type	Features	Order no.
PSSu E F 4DI	Electronic module, base type	312200
PSSu E F 4DI-T	Electronic module, T-type	314200
PSSu E F 4DI-R	Electronic module, R-type	315200

10.2 Accessories

Base modules

Product type	Features	Order no.
PSSu BP 1/8 S	Base module without C-rail with screw terminals	312600
PSSu BP 1/8 S-T	Base module without C-rail with screw terminals, T-type	314600
PSSu BP 1/8 C	Base module without C-rail with cage clamp terminals	312601
PSSu BP 1/8 C-T	Base module without C-rail with cage clamp terminals, T-type	314601
PSSu BP 1/12 S	Base module without C-rail with screw terminals	312618
PSSu BP 1/12 S-T	Base module without C-rail with screw terminals, T-type	314618
PSSu BP 1/12 C	Base module without C-rail with cage clamp terminals	312619
PSSu BP 1/12 C-T	Base module without C-rail with cage clamp terminals, T-type	314619
PSSu BP-C1 1/12 S	Base module with C-rail and screw terminals	312622
PSSu BP-C1 1/12 S-T	Base module with C-rail and screw terminals, T-type	314622
PSSu BP-C1 1/12 C	Base module with C-rail and cage clamp terminals	312623
PSSu BP-C1 1/12 C-T	Base module with C-rail and cage clamp terminals, T-type	314623

11 EC declaration of conformity for PSSu E F 4DI and PSSu E F 4DI-T

This product/these products meet the requirements of the directive 2006/42/EC on machinery of the European Parliament and of the Council. The complete EC Declaration of Conformity is available on the Internet at www.pilz.com/downloads.

Representative: Pilz GmbH & Co. KG, Felix-Wankel-Str. 2, 73760 Ostfildern, Germany

12 UKCA-Declaration of Conformity for PSSu E F 4DI and PSSu E F 4DI-T

This product(s) complies with following UK legislation: Supply of Machinery (Safety) Regulation 2008.

The complete UKCA Declaration of Conformity is available on the Internet at www.pilz.com/downloads.

Representative: Pilz Automation Technology, Pilz House, Little Colliers Field, Corby, Northamptonshire, NN18 8TJ United Kingdom, eMail: mail@pilz.co.uk

► Support

Technical support is available from Pilz round the clock.

Americas

Brazil

+55 11 97569-2804

Canada

+1 888 315 7459

Mexico

+52 55 5572 1300

USA (toll-free)

+1 877-PILZUSA (745-9872)

Asia

China

+86 400-088-3566

Japan

+81 45 471-2281

South Korea

+82 31 778 3300

Australia and Oceania

Australia

+61 3 95600621

New Zealand

+64 9 6345350

Europe

Austria

+43 1 7986263-444

Belgium, Luxembourg

+32 9 3217570

France

+33 3 88104003

Germany

+49 711 3409-444

Ireland

+353 21 4804983

Italy, Malta

+39 0362 1826711

Scandinavia

+45 74436332

Spain

+34 938497433

Switzerland

+41 62 88979-32

The Netherlands

+31 347 320477

Türkiye

+90 216 5775552

United Kingdom

+44 1536 462203

You can reach our international hotline on:

+49 711 3409-222

support@pilz.com

Pilz develops environmentally-friendly products using ecological materials and energy-saving technologies. Offices and production facilities are ecologically designed, environmentally-aware and energy-saving. So Pilz offers sustainability, plus the security of using energy-efficient products and environmentally-friendly solutions.



CECE[®], CHRE[®], CMSE[®], INDUSTRIAL P[®], Leansafe[®], Myzei[®], PAS4000[®], PASscal[®], PASconfig[®], Pilz[®], PIT[®], PMSprimo[®], PMSprotego[®], PMCiendo[®], PMD[®], PMI[®], PNOZ[®], Primo[®], PSEN[®], PSS[®], PSS[®], PVIS[®], SafetyBUS p[®], SafetyNET p[®], THE SPIRIT OF SAFETY[®] are registered and protected trademarks of Pilz GmbH & Co. KG in some countries. We would point out that product features may vary from the details stated in this document, depending on the status at the time of publication and the scope of the equipment. We accept no responsibility for the validity, accuracy and entirety of the text and graphics presented in this information. Please contact our Technical Support if you have any questions.

21310-EN-10, 2023-08 Printed in Germany
© Pilz GmbH & Co. KG, 2019

We are represented internationally. Please refer to our homepage www.pilz.com for further details or contact our headquarters.

Headquarters: Pilz GmbH & Co. KG, Felix-Wankel-Straße 2, 73760 Ostfildern, Germany
Telephone: +49 711 3409-0, E-Mail: info@pilz.com, Internet: www.pilz.com

PILZ
THE SPIRIT OF SAFETY