



► PSSu E F 2DOR 8(-T)(-R)

PILZ
THE SPIRIT OF SAFETY

Operating Manual-21334-EN-15

- Decentralised system PSSuniversal I/O



This document is the original document.

Where unavoidable, for reasons of readability, the masculine form has been selected when formulating this document. We do assure you that all persons are regarded without discrimination and on an equal basis.

All rights to this documentation are reserved by Pilz GmbH & Co. KG. Copies may be made for the user's internal purposes. Suggestions and comments for improving this documentation will be gratefully received.

Pilz®, PIT®, PMI®, PNOZ®, Primo®, PSEN®, PSS®, PVIS®, SafetyBUS p®, SafetyEYE®, SafetyNET p®, the spirit of safety® are registered and protected trademarks of Pilz GmbH & Co. KG in some countries.



SD means Secure Digital

1	Introduction	5
1.1	Validity of documentation	5
1.1.1	Retaining the documentation	5
1.1.2	Terminology: System environment A and B	5
1.2	Definition of symbols	6
2	Overview	7
2.1	Module structure	7
2.2	Module features	7
2.3	Front view	8
3	Safety	10
3.1	Intended use	10
3.2	Safety regulations	12
3.2.1	Use of qualified personnel	12
3.2.2	Warranty and liability	13
3.2.3	Disposal	13
4	Function description	14
4.1	Block diagram	14
4.2	Module features	14
4.2.1	Functions	14
4.2.2	Integrated protection mechanisms	16
4.2.3	Reaction times	16
4.3	Configuration	17
4.3.1	PSSu assignment in system environment A	17
4.3.1.1	Addresses in the process image	17
4.3.2	PSSu assignment in system environment B	17
5	Installation	18
5.1	General installation guidelines	18
5.1.1	Dimensions	18
5.2	Installing the base module	19
5.3	Inserting and removing an electronic module	20
5.3.1	Inserting an electronic module	21
5.3.2	Removing an electronic module	22
5.3.3	Changing an electronic module during operation	22
6	Wiring	23
6.1	General wiring guidelines	23
6.1.1	Mechanical connection of the base modules	23
6.2	Terminal configuration	25
6.3	Connecting the module	27
6.4	Function test during commissioning	28
7	Operation	29
7.1	Messages	29
7.2	Display elements	30

7.2.1	Display elements for module diagnostics	30
7.2.2	Display elements for an output's FS enable	31
7.2.3	Display elements for output status	31
8	Technical details	32
8.1	Safety characteristic data	38
8.2	Service life graphs	39
9	Supplementary data	41
9.1	Permitted operating height	41
10	Order reference	42
10.1	Product	42
10.2	Accessories	42
11	EC declaration of conformity for PSSu E F 2DOR 8 and PSSu E F 2DOR 8-T	43
12	UKCA-Declaration of Conformity for PSSu E F 2DOR 8 and PSSu E F 2DOR 8-T	44

1 Introduction

1.1 Validity of documentation

This documentation is valid for the product types PSSu E F 2DOR 8, PSSu E F 2DOR 8-T and PSSu E F 2DOR 8-R. It is valid until new documentation is published.

This operating manual explains the function and operation, describes the installation and provides guidelines on how to connect the product.

1.1.1 Retaining the documentation

This documentation is intended for instruction and should be retained for future reference.

1.1.2 Terminology: System environment A and B

The PSSu system can be used in two different system environments. The module's application area is described in the chapter "Intended Use" of the manual.

The distinction is made between

- ▶ PSSu in system environment A
- ▶ PSSu in system environment B

The distinction is based on the application area of the PSSu system.

PSSu in system environment A may be used in the

- ▶ Decentralised system PSSu I/O
- ▶ **Not** in the automation system PSS 4000

PSSu in system environment B may be used in the

- ▶ Automation system PSS 4000, e.g. with
 - Decentralised system PSSu I/O with SafetyNET p
 - Control system PSSu PLC
 - Control system PSSu multi

1.2 Definition of symbols

Information that is particularly important is identified as follows:



DANGER!

This warning must be heeded! It warns of a hazardous situation that poses an immediate threat of serious injury and death and indicates preventive measures that can be taken.



WARNING!

This warning must be heeded! It warns of a hazardous situation that could lead to serious injury and death and indicates preventive measures that can be taken.



CAUTION!

This refers to a hazard that can lead to a less serious or minor injury plus material damage, and also provides information on preventive measures that can be taken.



NOTICE

This describes a situation in which the product or devices could be damaged and also provides information on preventive measures that can be taken. It also highlights areas within the text that are of particular importance.



INFORMATION

This gives advice on applications and provides information on special features.

2 Overview

2.1 Module structure

A module consists of

- ▶ Electronic module and
- ▶ Base module with
 - Screw terminals or
 - Cage clamp terminals

The base modules are the carrier units for the electronic modules and are used to connect the field wiring. The electronic modules are inserted on to the base modules and determine the module's function.

Details of the base modules that can be used are available in the chapter entitled “Intended Use”.

2.2 Module features

The product has the following features:

- ▶ Relay contacts
 - N/O contact
 - Volt-free
 - Current load capacity per output: 8 A
- ▶ LEDs for:
 - Switch status of each output
 - Module error
- ▶ For failsafe applications in system environment A and B
- ▶ T-type:
 - PSSu E F 2DOR 8-T: for increased environmental requirements
- ▶ R-type:
 - PSSu E F 2DOR 8-R: for railway applications

2.3 Front view

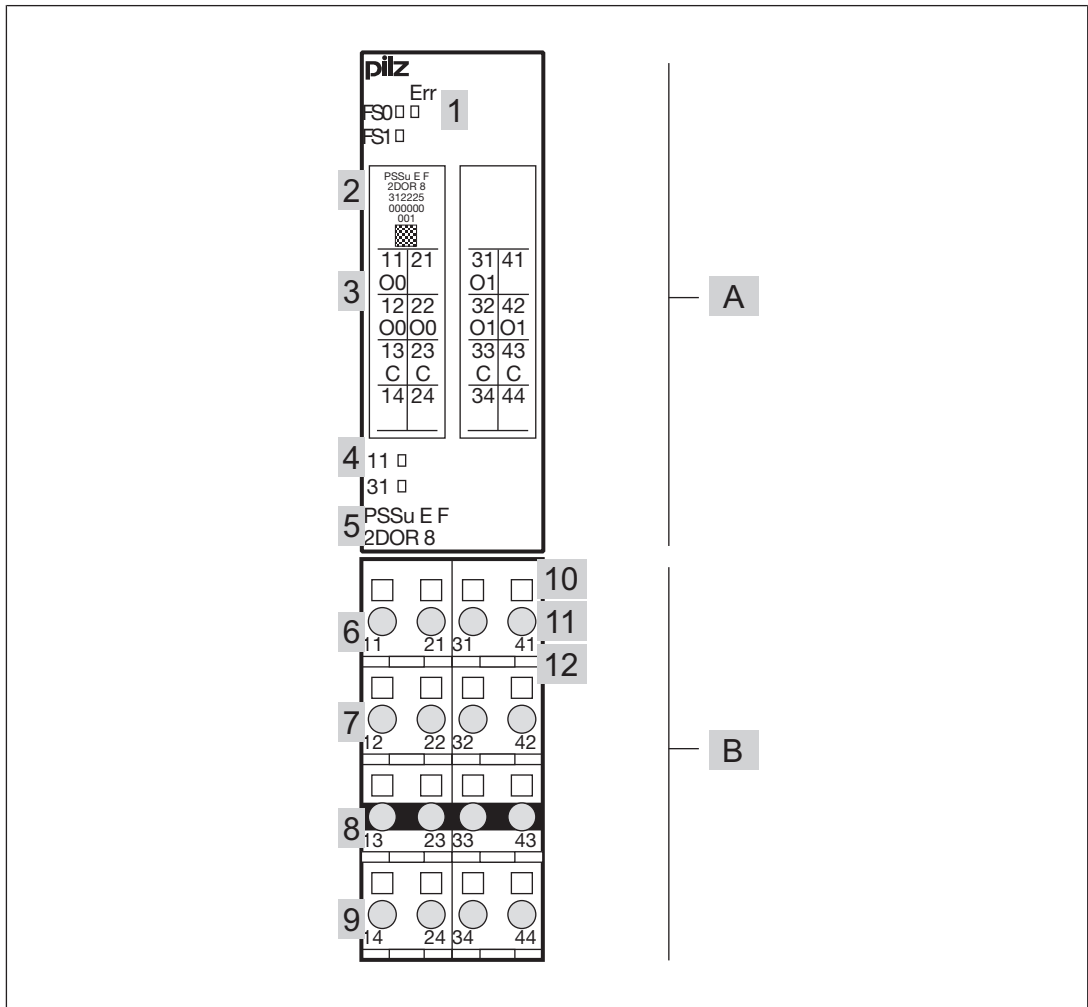

Legend:

- ▶ A: Electronic module
- ▶ B: Base module
- ▶ 1: LEDs for
 - Module diagnostics
 - Displaying an output's FS enable (enable principle)
- ▶ 2: Labelling strip with:
 - Name of electronic module
 - Order number
 - Serial number
 - Hardware version number
 - 2D code
- ▶ 3: Labelling strip for the terminal configuration on the base module
- ▶ 4: Status LEDs
- ▶ 5: Name of electronic module
- ▶ 6: Connection level 1

- ▶ 7: Connection level 2
- ▶ 8: Connection level 3
- ▶ 9: Connection level 4
- ▶ 10: Square mounting holes (connection levels 1, 2, 3 and 4)
 - With screw to loosen/tighten the screw terminal on base modules with screw terminals
 - With mechanism to operate the cage clamp on base modules with cage clamp terminals
- ▶ 11: Round connection holes (connection levels 1, 2, 3 and 4) for connecting the signal lines
- ▶ 12: Mounting slot for colour marker to label the connection level (connection levels 1, 2, 3 and 4)

3 Safety

3.1 Intended use



INFORMATION

If the module name is not explicitly named, the details apply to all the variants of the module.

Use in a PSSu system

The module may be used in a PSSu system in system environment A and B.

The head module establishes in what system environment a PSSu system can be used.

▶ System environment A

A PSSu system in system environment A is a decentralised system PSSu I/O with a field-bus, but without SafetyNET p interface. The automation system PSS 4000 does **not** belong to the system environment A.

▶ System environment

A PSSu system in system environment B is a PSSu system in the h automation system PSS 4000. The PSSu system can belong to one of the following performance classes:

- Decentralised system PSSu I/O (with SafetyNET p)
- Control system PSSu PLC
- Control system PSSu multi

Failsafe applications

The module may be used for failsafe applications.

The module meets the requirements of EN IEC 61508 up to SIL 3.

Failsafe outputs

The module has failsafe outputs.

It provides failsafe outputs in accordance with IEC 61131-2. The module may be used to switch:

- ▶ Resistive loads
- ▶ Inductive loads

Particular application areas

▶ Increased environmental requirements

The module PSSu E F 2DOR 8-T is suitable for use where there are increased environmental requirements (see [Technical details](#) [ 32]).

▶ Lift applications

The modules PSSu E F 2DOR 8 and PSSu E F 2DOR 8-T can be used as a PESSRAL (programmable electronic system in safety-related applications for lifts) in accordance with the Lifts Directive 2014/33/EU. The modules meet the requirements in accordance with EN 81-20, EN 81-50 for passenger and goods lifts the requirements in accordance with EN 115-1 for escalators and moving walks.

The module/the safety controller should be installed in a protected environment. Example: Protected inside space or control cabinet with protection class and corresponding air conditioning specified in [Technical details](#)  32].

▶ **Furnaces**

The module PSSu E F 2DOR 8 can be used in furnaces in accordance with EN 298. If the module's relay outputs shut down the entire fuel supply and the furnace is used in continuous operation, appropriate external measures must be used to establish diversity of the shutdown elements (requirement of EN 50156-1). For example, an appropriate measure may be an additional, monitored switching element (contactor or relay), which is activated by a safe semiconductor output and is switched in series with both relay outputs.

▶ **Railway applications**

The module PSSu E F 2DOR 8-R is **only** intended and certified for use in railway applications (CENELEC) where there are increased environmental requirements (see [Technical details](#)  32]). Any other use is **not** permitted.

Permitted operating height

With reference to the standard IEC 61131-2 the values stated in the technical details for ambient temperature are reduced at heights >2000 m operating height above sea level (see [Supplementary data](#)  41]).

EMC-compliant installation

Intended use includes making the electrical installation EMC-compliant. Please refer to the guidelines stated in the "PSSuniversal Installation Manual". The module is intended for use in an industrial environment. Interference may occur if used within a domestic environment.

Improper use

The following is deemed improper use in particular

- ▶ Any component, technical or electrical modification to the module,
- ▶ Use of the module outside the areas described in this operating manual,
- ▶ Any use of the module that is not in accordance with the technical details.

Software tools

The module is supported by:

- ▶ PSSuniversal Configurator and PSSuniversal Assistant from Version 1.4.0
- ▶ PAS4000 from Version 1.0.0

**INFORMATION**

We recommend that you always use the latest version of the software tool (download from www.pilz.com).

Base modules

The PSSu E F 2DOR 8 module may be used in conjunction with the following base modules:

- ▶ PSSu BP 2/16 S
- ▶ PSSu BP 2/16 C
- ▶ PSSu BP-C 2/16 S
- ▶ PSSu BP-C 2/16 C

The PSSu E F 2DOR 8-T and PSSu E F 2DOR 8-R modules may be used in conjunction with the following base modules:

- ▶ PSSu BP 2/16 S-T
- ▶ PSSu BP 2/16 C-T
- ▶ PSSu BP-C 2/16 S-T
- ▶ PSSu BP-C 2/16 C-T

3.2 Safety regulations

3.2.1 Use of qualified personnel

The products may only be assembled, installed, programmed, commissioned, operated, maintained and decommissioned by persons who are competent to do so.

A competent person is a qualified and knowledgeable person who, because of their training, experience and current professional activity, has the specialist knowledge required. In order to inspect, assess and handle products, devices, systems, plant and machinery, this person must be familiar with the state of the art and the applicable national, European and international laws, directives and standards.

It is the company's responsibility only to employ personnel who

- ▶ Are familiar with the basic regulations concerning health and safety / accident prevention,
- ▶ Have read and understood the information provided in the section entitled Safety
- ▶ Have a good knowledge of the generic and specialist standards applicable to the specific application.

3.2.2 **Warranty and liability**

All claims to warranty and liability will be rendered invalid if

- ▶ The product was used contrary to the purpose for which it is intended,
- ▶ Damage can be attributed to not having followed the guidelines in the manual,
- ▶ Operating personnel are not suitably qualified,
- ▶ Any type of modification has been made (e.g. exchanging components on the PCB boards, soldering work etc.).

3.2.3 **Disposal**

- ▶ In safety-related applications, please comply with the mission time T_M in the safety-related characteristic data.
- ▶ When decommissioning, please comply with local regulations regarding the disposal of electronic devices (e.g. Electrical and Electronic Equipment Act).

4 Function description

4.1 Block diagram

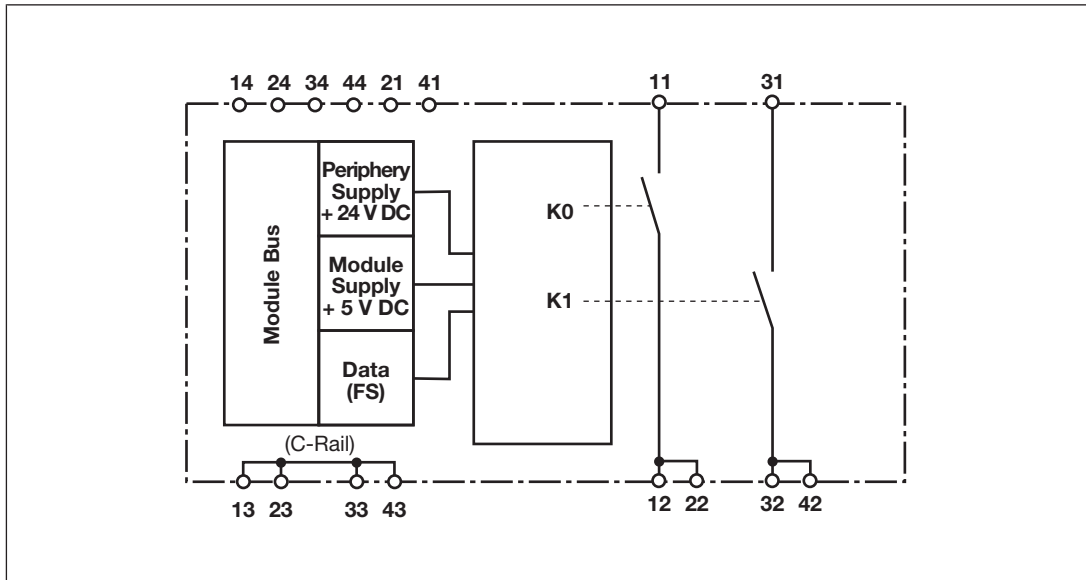

4.2 Module features

4.2.1 Functions

Module supply

- ▶ The module supply provides the module with voltage.

Outputs

- ▶ The head module sets the output status via the module bus.
- ▶ The relationship between the load current and the operating temperature is illustrated in the following derating diagram. The operating point should be below the characteristic curve.

PSSu E F 2DOR 8: Derating diagram for the permitted ambient temperature T dependent on load current I

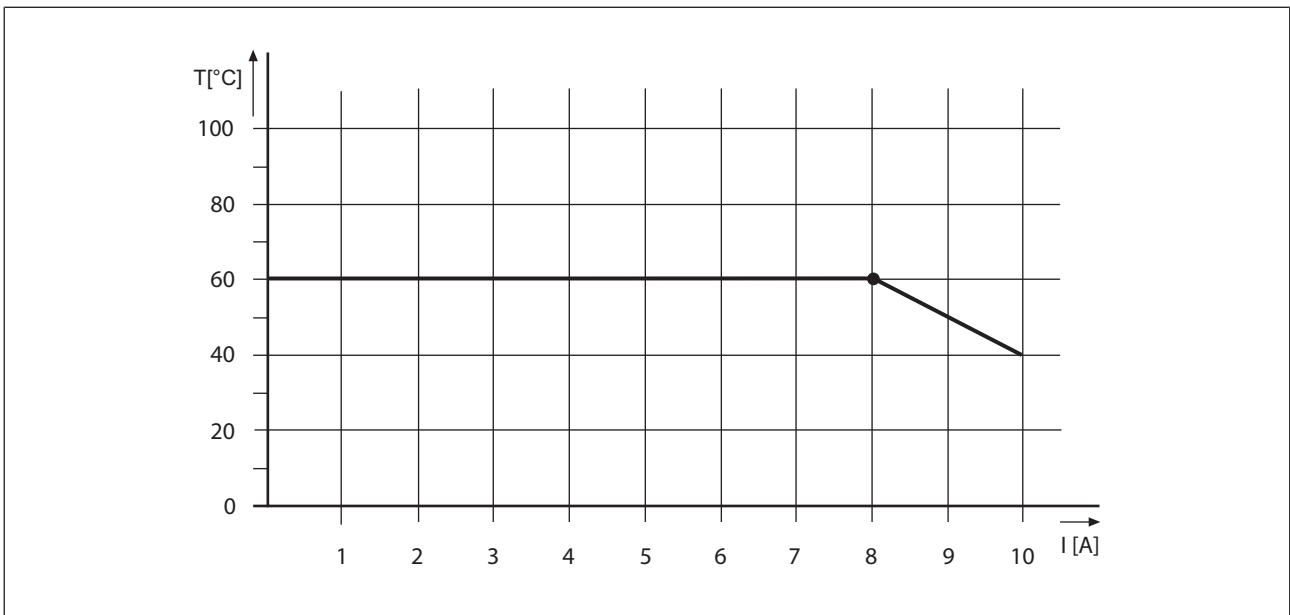

PSSu E F 2DOR 8(-T)(-R): Derating diagram for the permitted ambient temperature T dependent on load current I

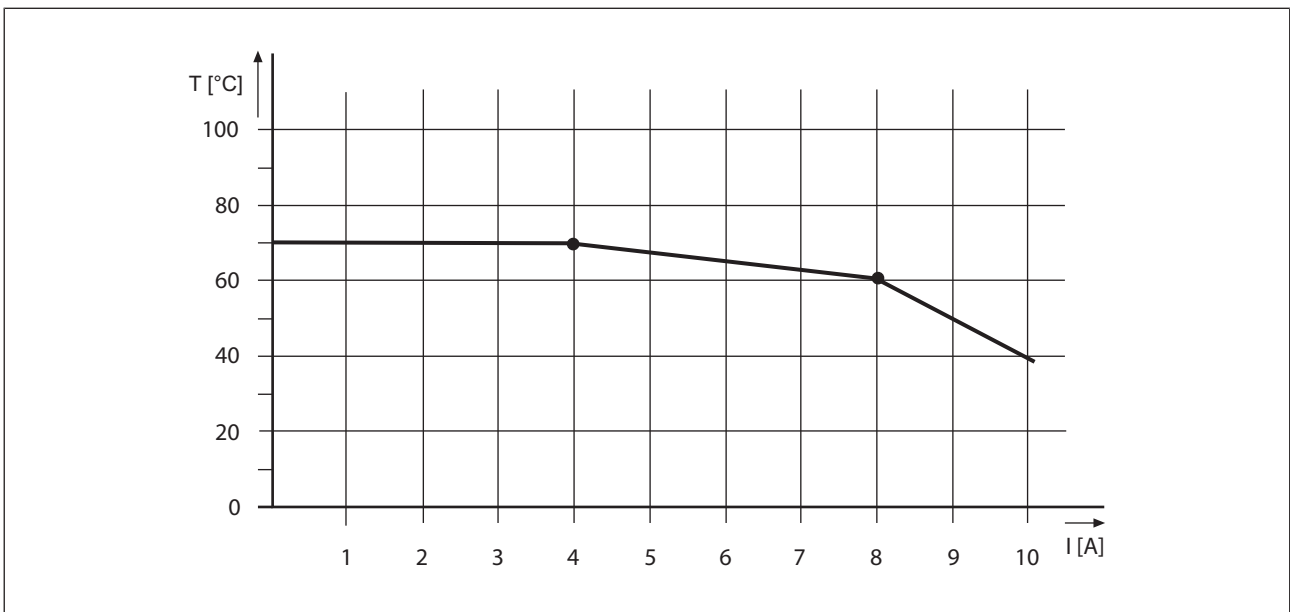

4.2.2 Integrated protection mechanisms

When the PSSu E F PS1(-T) or PSSu E F PS2(-T)(-R) is used to supply the system, the module supply is buffered for 20 ms if the supply voltage is interrupted.

The module has the following protection mechanisms:

- ▶ 1 monitored relay contact per output
- ▶ Protective separation between both relay contacts (see Technical details)
- ▶ Protective separation between both relay contacts and the periphery supply as well as the module supply, in accordance with DIN VDE 0110 overvoltage category 2 in a protected industrial network
- ▶ Temperature monitoring

The module provides the following diagnostic data:

- ▶ Start-up error
- ▶ Configuration error
- ▶ FS communication error
- ▶ Bus termination error
- ▶ Temperature error: Too warm
- ▶ Temperature error: Too hot
- ▶ Relay control error
- ▶ Relay error

4.2.3 Reaction times

Information on the reaction times of the outputs can be found in the PSSuniversal System Description.

4.3 Configuration

4.3.1 PSSu assignment in system environment A

Functions for the FS outputs of a PSSu are defined in the PSSuniversal Configurator on the PSS WIN-PRO system software:

- ▶ Read access through the standard bus system
(configured per module):
"R" configuration
- ▶ Read/write access through the standard bus system
(configured per FS output):
"&" configuration (local enable principle)
- ▶ Optimisation of ST process image by combining adjacent bits of the same type.
"*)" configuration



INFORMATION

The PSSuniversal Configurator on the PSS WIN-PRO system software must be used to define the I/O-Groups to which FS inputs and outputs belong (SafetyBUS p). The PSSu can be divided into sections A and B for this purpose. All the FS outputs on a PSSu always belong to section A.

Section A and section B on a PSSu may belong to different I/O-Groups.

Further information on configuration is available in the PSSuniversal Configurator's online help.

4.3.1.1 Addresses in the process image

The module occupies 2 consecutive bit addresses in the process image. The process image in which the outputs are shown depends on the configuration.

With write access ("&"), the Bits in the ST-PIO are used to switch the FS outputs with the local enable principle.

Configuration	SafetyBUS p	Standard bus system	
	FS-PIO	ST-PII	ST-PIO
None	2 Bit (e. g.: 32.00 ... 32.01)	---	---
Read ST ("R")		2 Bit	---
ST read and write ("&")		2 Bit	2 Bit

4.3.2 PSSu assignment in system environment B

Data access is via pre-defined I/O data types:

I/O data name	I/O data type	I/O data element	Meaning
O0(11,21)	FS_O_DO	Data: SAFEBOOL	Output data O0
O1(31,32)	FS_O_DO	Data: SAFEBOOL	Output data O1

5 Installation

5.1 General installation guidelines

Please refer also to the PSSuniversal Installation Manual.



NOTICE

Damage due to electrostatic discharge!

Electrostatic discharge can damage components. Ensure against discharge before touching the product, e.g. by touching an earthed, conductive surface or by wearing an earthed armband.

5.1.1 Dimensions

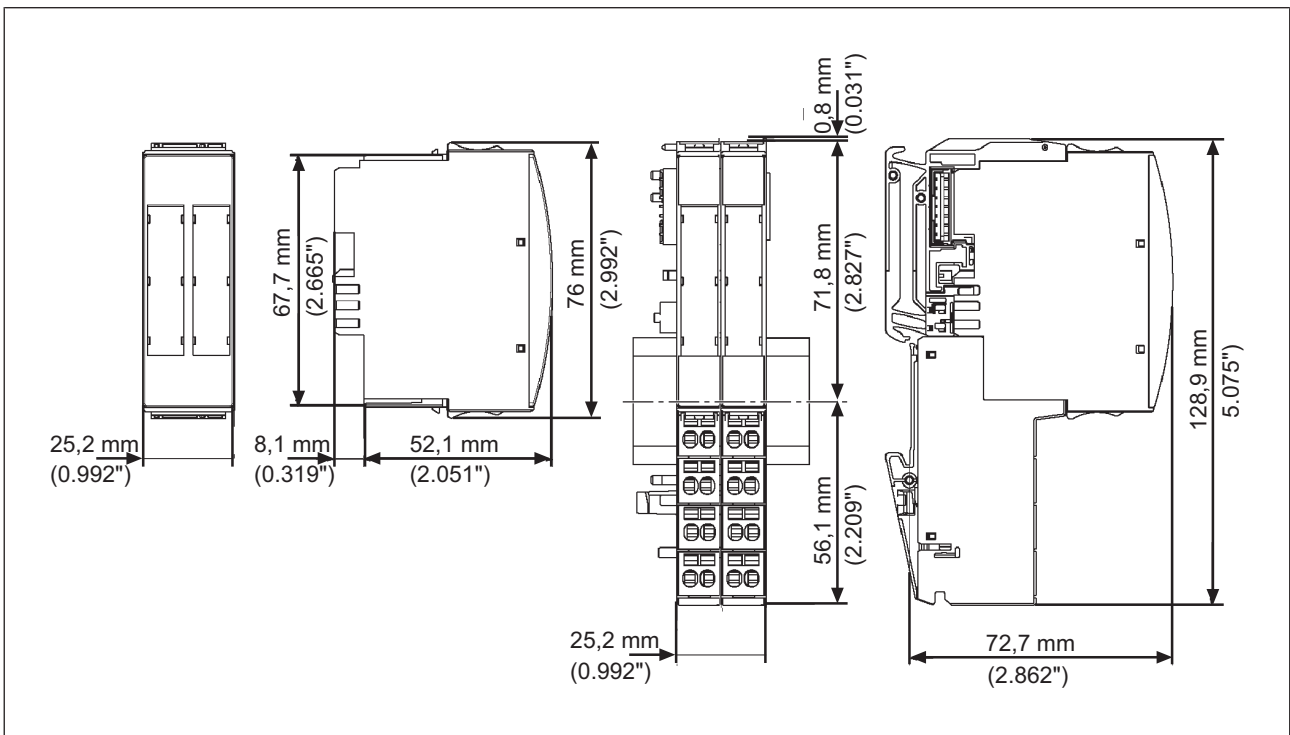

5.2 Installing the base module

Prerequisite:

- ▶ The head module must be installed.
- ▶ If the head module does not have an integrated power supply, a supply voltage module must be installed to the right of the head module.

Please note:

- ▶ For mechanical reasons it is not possible to mix base modules with screw terminals and base modules with cage clamp terminals.
- ▶ All contacts should be protected from contamination.
- ▶ The mechanics of the base modules are designed for 50 plug in/out cycles.

Procedure:

- ▶ We recommend that you wire up the base modules before inserting the electronic modules.
- ▶ Slot the groove on the base module on to the mounting rail from below [1].
- ▶ Push the base module back [2] until you hear it lock into position.
- ▶ On the mounting rail, slide the base module to the left until you hear the two lateral mounting hooks on the adjacent module lock into position [3].

Schematic representation:

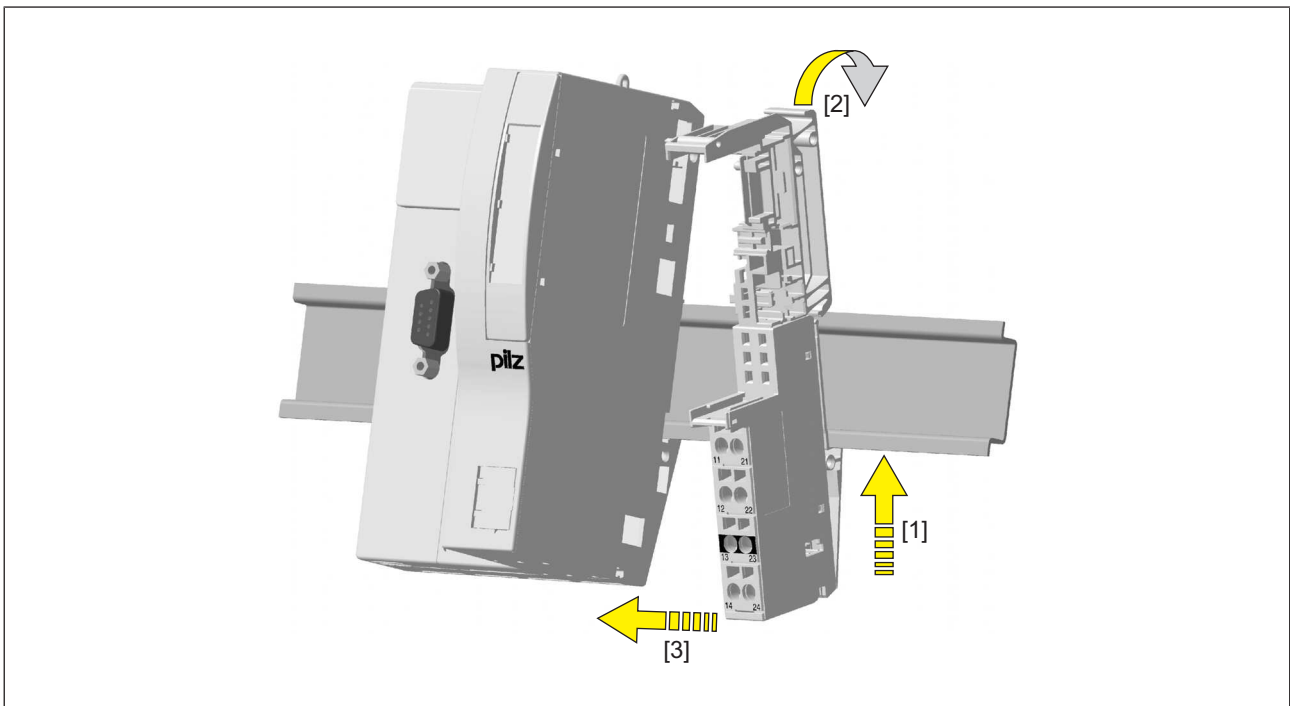

5.3 Inserting and removing an electronic module

Please note:

- ▶ Only insert on to base modules that are already installed.
- ▶ Preferably these base modules should be ready wired.
- ▶ Electronic modules with outputs may only be inserted and removed when the load is switched off. Unforeseeable error reactions may be triggered if modules are inserted and removed under load.
- ▶ When an electronic module is plugged into a base module for the first time, one part of the coding element remains on the electronic module, while its counterpart is fixed on to the base module. This is how the base module is coded.
- ▶ The mechanics of the electronic modules are designed for 50 plug in/out cycles.

5.3.1 Inserting an electronic module

Procedure:

- ▶ The electronic module must audibly lock into position [1].
- ▶ Mark the electronic module using the labelling strips [2].

Schematic representation:

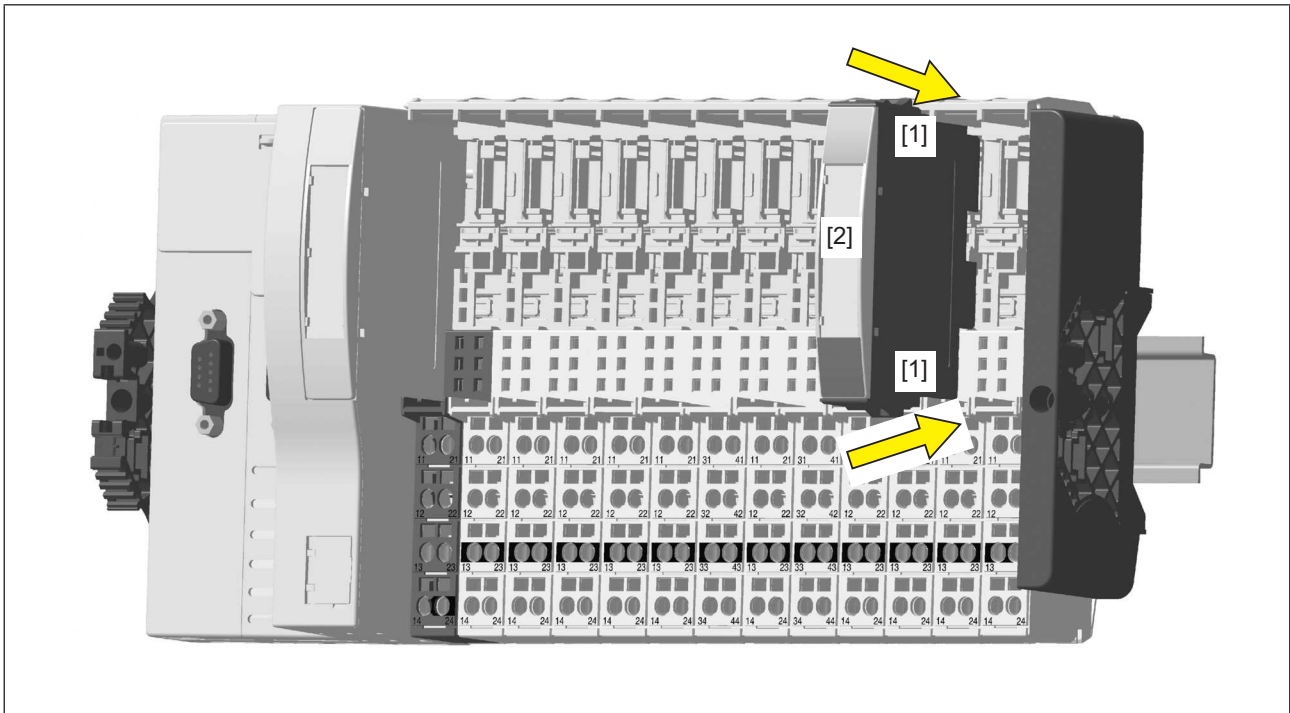

5.3.2 Removing an electronic module

Procedure:

- ▶ Press the locking mechanisms [1] together simultaneously.
- ▶ Pull out the electronic module [2].

Schematic representation:

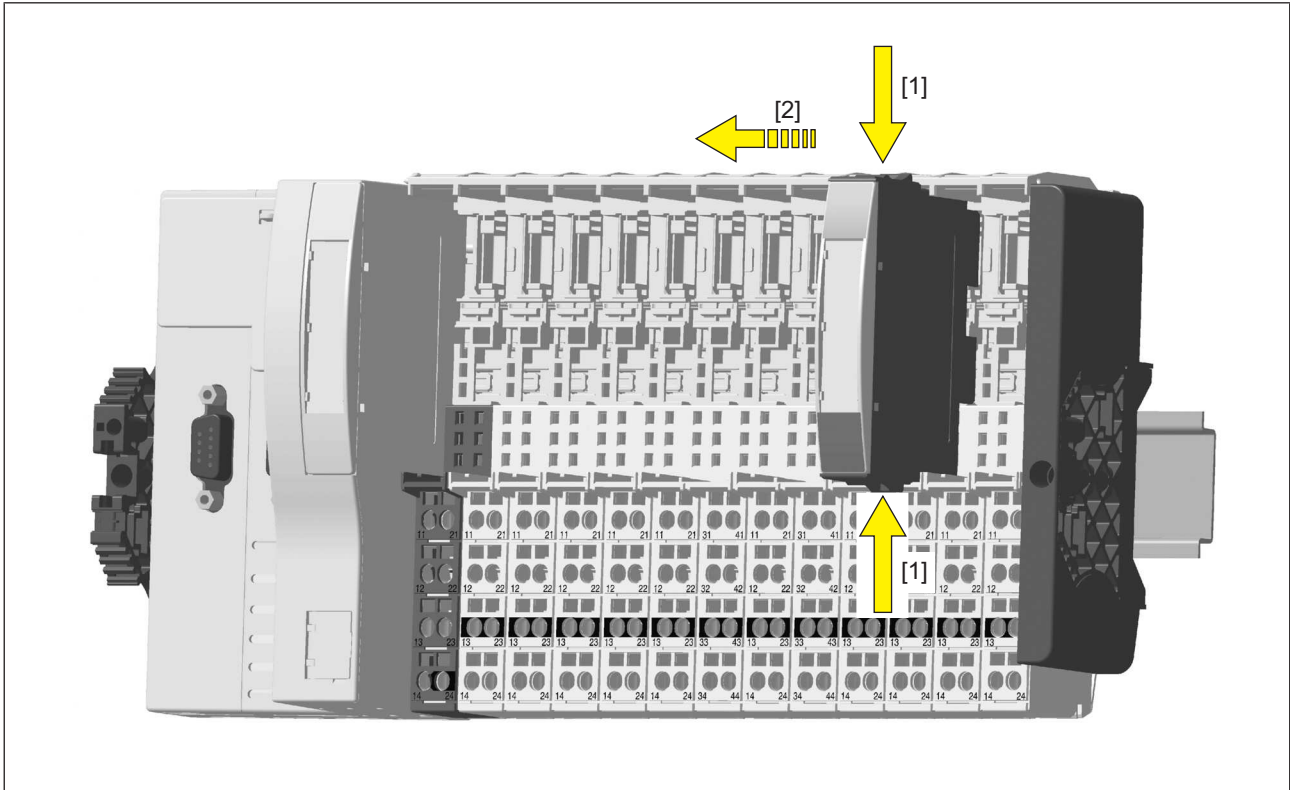

5.3.3 Changing an electronic module during operation

It is possible to change an electronic module during operation. The configuration data is retained when a module is changed.

Effects:

- ▶ System environment A:
 - In the event of a potential FS communication error, the FS section of the PSSu system and all relevant I/O-Groups (SafetyBUS p) switch to a STOP condition.
- ▶ System environment B:
 - All FS hardware outputs on the PSSu system switch to a safe condition.
 - The substitute values are used for the modules' FS outputs, with Valid Bits = FALSE.



CAUTION!

Sparking can cause interference and errors!

Only change the module when the load is switched off!

6 Wiring

6.1 General wiring guidelines

Please note:

- ▶ If short circuits occur between the cable from the output to the load and a supply line, it will no longer be possible to switch off the load. Possible remedies:
 - Use separate multicore cable for supply voltages
 - Use dual actuators, e.g. two contactors in series.
 - Use an additional shutdown device such as a main contactor
- ▶ Use appropriate wiring to exclude short circuits between the outputs!
- ▶ The actuators may be connected using unshielded cables.
- ▶ To prevent contact welding, a fuse should be connected before the output contacts (see Technical details).
- ▶ With inductive loads, adequate protection circuit must be provided on all output contacts.
- ▶ When installed at a height of over 2000 m above sea level, only protective extra low voltage may be connected to the relay contacts.
- ▶ If voltages higher than 50 VAC or 120 VDC are connected to the relay contacts, please note the following:
 - Specific accident prevention regulations apply.
 - For safety reasons, only the protective earth (PE) may be connected to the C-rail of the supply group.
- ▶ Use copper wiring.

6.1.1 Mechanical connection of the base modules

Procedure:

- ▶ Use a flat blade screwdriver (DIN 5264-A)!

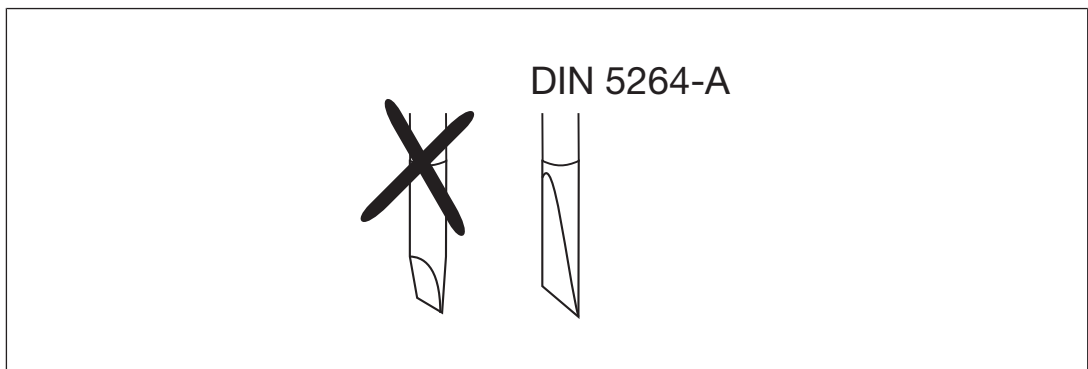

- ▶ Strip the wire back 8 mm.
- ▶ If necessary, label the connection level with a colour marker [3].
- ▶ Base module with screw terminals:
 - Use a screwdriver to loosen the screw on the screw terminal [1]
 - Insert the stripped cable into the round fixing hole [2], as far as it will go.
 - Tighten up the screw on the screw terminal.

- Check that the cable is firmly seated.
- ▶ Base module with cage clamp terminals:
 - Insert the screwdriver [4] into the square hole [1].
 - Insert the stripped cable into the round fixing hole [2], as far as it will go [5].
 - Pull out the screwdriver [6].
 - Check that the cable is firmly seated.

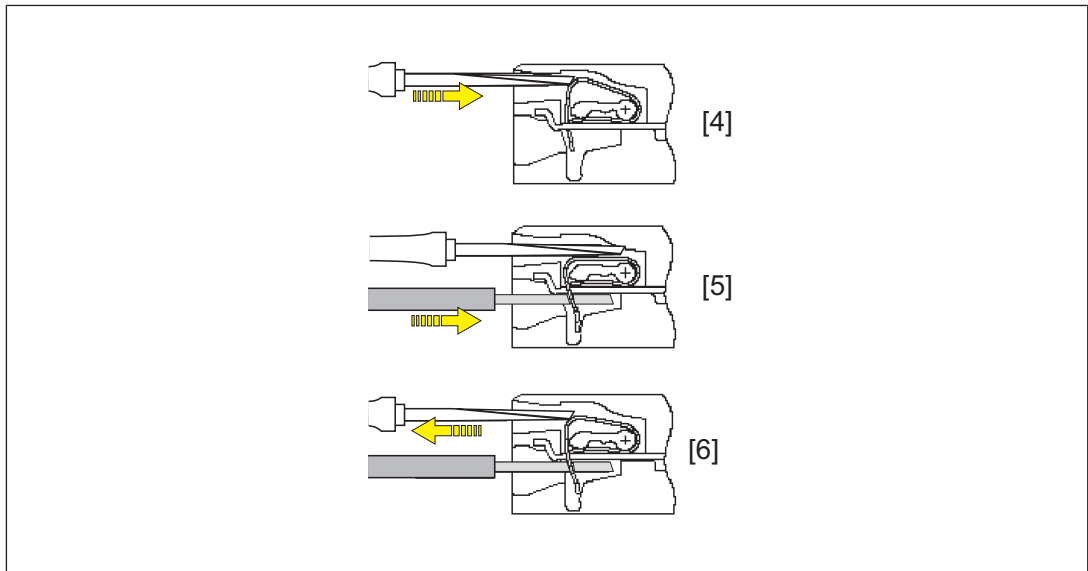
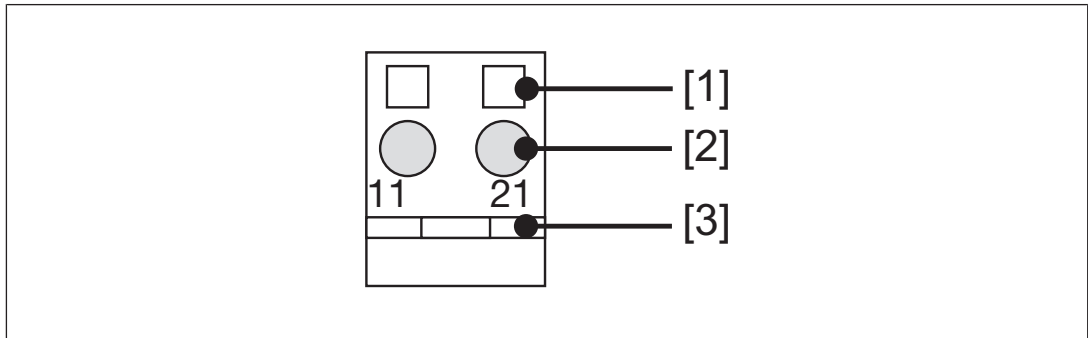

Please note:

- ▶ The minimum cable cross section for field connection terminals on the base modules is 0.14 mm² (AWG26).
- ▶ The maximum cable cross section for field connection terminals is:
 - Digital inputs: 1.5 mm² (AWG16)
 - Digital outputs: 2.0 mm² (AWG14)
 - Inputs/outputs on the counter modules: 1.5 mm² (AWG16)
 - Analogue inputs/outputs: 1.5 mm² (AWG16)
 - Communication cables: 1.5 mm² (AWG16)
 - Test pulse outputs: 1.5 mm² (AWG16)
 - Power supply: 2.5 mm² (AWG12)
 - Functional earth: 2.5 mm² (AWG12)

- ▶ On base modules with screw terminals:
 - If you use a multi-strand cable to connect the I/Os, it is recommended that you use ferrules conforming to Parts 1 and 2 of DIN 46228, 0.14 ... 1.5 mm², Form A or C, although this is not essential. To crimp the ferrules you can use crimp pliers (crimp form A or C) conforming to EN 60947-1, such as the PZ 1.5 or PZ 6.5 from Weidmüller, for example.
 - Maximum torque setting: 0.8 Nm
- ▶ Use copper wiring.

6.2 Terminal configuration

Base module	Terminal configuration	
With C-rail	11: Output O0 Relay contact 1 21: Not assigned 12-22: Output O0 Relay contact 2 (12-22 linked within the base module) 13-23: C-rail supply (13-23-33-43 linked within the base module) 14-24: Not assigned 31: Output O1 Relay contact 1 41: Not assigned 32-42: Output O1 Relay contact 2 (32-42 linked within the base module) 34-44: Not assigned	

Base module	Terminal configuration	
Without C-rail	<p>11: Output O0 Relay contact 1</p> <p>21: Not assigned</p> <p>12-22: Output O0 Relay contact 2 (12-22 linked within the base module)</p> <p>14-24: Not assigned</p> <p>31: Output O1 Relay contact 1</p> <p>41: Not assigned</p> <p>32-42: Output O1 Relay contact 2 (32-42 linked within the base module)</p> <p>34-44: Not assigned</p>	

6.3 Connecting the module

Output circuit	With C-rail
<p>Single-channel actuator Switches 230 VAC</p>	
<p>Dual-channel actuator Switches 230 VAC</p>	

6.4 Function test during commissioning

An error must be simulated for each safety-related output during commissioning: The anticipated error reaction must occur when an output has a short circuit to a supply voltage.



INFORMATION

The short circuit test must be performed on the load and not on the output terminal.

7 Operation



NOTICE

The safety functions should be checked after initial commissioning and each time the plant/machine is changed. The safety functions may only be checked by qualified personnel.

When the relay outputs are switched on, the mechanical contact on the relay cannot be tested automatically. Depending on the operational environment, measures to detect the non-opening of switching elements may be required under some circumstances.

When the product is used in accordance with the European Machinery Directive, a check must be carried out to ensure that the safety contacts on the relay outputs open correctly. Start the device again or open the safety contacts (switch off output), so that the internal diagnostics can check the correct opening of the safety contacts

- ▶ for SIL 3/PL e at least 1x per month
- ▶ for SIL 2/PL d at least 1x per year

7.1 Messages

A module error is displayed via the "Err" LED (see section entitled "Display elements"). It is signalled to the head module and then entered in the

- ▶ Error stack, with PSSu in system environment A
- ▶ Diagnostic log, with PSSu in system environment B.

of the head module.

The module can detect the following errors:

Module error	Explanation	Remedy
Start-up error	Error as the PSSu system starts up	Change faulty module.
Configuration error	Incorrect module type configured.	The configured hardware registry does not match the actual hardware registry.
FS communication error	Error during FS communication	Change faulty module.
Bus termination error	There is no terminating plate or there is a bad contact with the module bus.	Install a terminating plate with integrated end bracket or insert the base modules together correctly.
Temperature error: too warm ⁽¹⁾	Ambient temperature too high: Error stack entry/diagnostic log entry	Ensure there is sufficient ventilation in the control cabinet or prevent overload.
Temperature error: too hot ⁽¹⁾	Ambient temperature too high: Reset the module and stop the affected I/O-Groups (SafetyBUS p)	Ensure there is sufficient ventilation in the control cabinet or prevent overload.
Relay control error	Error during cyclical monitoring test of the relay coils	Change faulty relay module.

Module error	Explanation	Remedy
Relay error	A relay position is faulty. Possible cause: Defective relay contact	Change faulty relay module.
Error in the local enable principle	FS output has reacted incorrectly or unexpectedly	Check the configuration of the FS output, or check the fieldbus signals in the FS and ST section.

(¹) There are two levels of overtemperature.

- ▶ Too warm:
If a module's temperature exceeds a threshold value, the module sends a warning to the head module. If the temperature drops back below the threshold value, the module sends an all-clear.
- ▶ Too hot:
If a module's temperature exceeds a further threshold value, the module sends an error message to the head module and triggers an I/O-Group stop.



7.2 Display elements

Legend

-  LED on
-  LED off

7.2.1 Display elements for module diagnostics

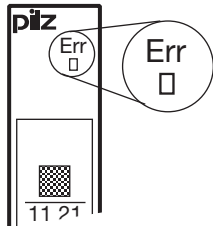
The module has an LED for displaying module errors ("Err" LED).

	LED			Meaning
	Name	Colour	Status	
	Err	---		No error
	Red		Module error	

7.2.2 Display elements for an output's FS enable

FS outputs are driven via a standard bus system using the local enable principle. An FS enable is assigned to each of these FS outputs. The status of that enable is displayed via the enable LEDs ("FS0" and "FS1").

	LED			Key
	Description	Colour	Status	
	FS0	---	●	No FS enable for output O0
		Yellow	☀	FS enable for output O0
FS1	---	●	No FS enable for output O1	
	Yellow	☀	FS enable for output O1	

7.2.3 Display elements for output status

Each output is assigned an LED for displaying the output status (LEDs "11" and "31").

	LED			Meaning		
	Designation	Colour	Status	Signal	Output	Terminal
	11	---	●	0 signal	O0 (Output 1)	11, 12-22
		Green	☀	1 signal		
	31	---	●	0 signal	O1 (Output 2)	31, 32-42
		Green	☀	1 signal		

8 Technical details

General	312225	314225	315225
Certifications	CE, EAC, KOSHA, TÜV, UKCA, cULus Listed	CE, EAC, KOSHA, TÜV, UKCA, cULus Listed	CE, EAC, TÜV, UKCA
Application range	Failsafe	Failsafe	Failsafe
Module's device code	0C03h	0C03h	0C03h
Number of FS output bits	2	2	2
Application in system environment A			
from FS firmware version, other head modules	4	4	–
from FS firmware version PSSu H F PN	1	1	–
Application in system environment B			
from FS firmware version, head modules	1.0.0	1.0.0	1.5.0
Electrical data	312225	314225	315225
Internal supply voltage (module supply)			
Module's power consumption	0,2 W	0,2 W	0,2 W
Periphery's supply voltage (periphery supply)			
Voltage range	16,8 - 30 V	16,8 - 30 V	16,8 - 30 V
Module's current consumption with no load	60 mA	60 mA	60 mA
Module's power consumption with no load	1,5 W	1,5 W	1,5 W
Max. power dissipation of module	2,5 W	2,5 W	2,5 W
Max. inrush current at UB	1 A	1 A	1 A
Permitted loads	inductive, resistive	inductive, resistive	inductive, resistive
Relay outputs	312225	314225	315225
Number of relay outputs	2	2	2
Utilisation category			
in accordance with the standard	EN 60947-4-1	EN 60947-4-1	EN 60947-4-1

Relay outputs	312225	314225	315225
Utilisation category of safety contacts			
AC1 at	250 V	250 V	250 V
Min. current	10 mA	10 mA	10 mA
Max. current	8 A	8 A	8 A
Max. power	2000 VA	2000 VA	2000 VA
AC1 with condensation at	–	30 V	30 V
Min. current	–	10 mA	10 mA
Max. current	–	8 A	8 A
Max. power	–	240 VA	240 VA
DC1 at	24 V	24 V	24 V
Min. current	10 mA	10 mA	10 mA
Max. current	8 A	8 A	8 A
Max. power	192 W	192 W	192 W
DC1 at	–	–	60 V
Min. current	–	–	10 mA
Max. current	–	–	1,66 A
Max. power	–	–	100 W
Utilisation category in accordance with the standard			
	EN 60947-5-1	EN 60947-5-1	EN 60947-5-1
Utilisation category of safety contacts			
AC15 at	230 V	230 V	230 V
Max. current	3 A	3 A	3 A
AC15 with condensation at	–	30 V	30 V
Max. current	–	3 A	3 A
DC13 (6 cycles/min) at	24 V	24 V	24 V
Max. current	5 A	5 A	5 A
DC13 at	–	–	60 V
Max. current	–	–	0,7 A
Utilisation category in accordance with UL			
Voltage	250 V AC G.U. (same polarity)	250 V AC G.U. (same polarity)	–
with current	3 A	3 A	–
Voltage	24 V DC G. P.	24 V DC G. P.	–
with current	3 A	3 A	–
Pilot Duty	B300, R300	B300, R300	–
External contact fuse protection, safety contacts in accordance with the standard			
	VDE 0660	VDE 0660	VDE 0660
Blow-out fuse, quick	10 A	10 A	10 A
Blow-out fuse, slow	6 A	6 A	6 A

Relay outputs	312225	314225	315225
Max. processing time of relay output tProcOM when signal changes from "1" to "0"	120 ms	120 ms	120 ms
Typ. processing time of relay output tProcOM when signal changes from "0" to "1"	20 - 60 ms	20 - 60 ms	20 - 60 ms
Contact material	AgCuNi + 0,2 µm Au	AgCuNi + 0,2 µm Au	AgCuNi + 0,2 µm Au
Environmental data	312225	314225	315225
Application site			
in accordance with the standard	–	–	EN 50125-3
Application site	–	–	Track area (1 m - 3 m)
in accordance with the standard	–	–	EN 61373
Application site	–	–	Category 1, Class A + B
Climatic suitability	EN 60068-2-1, EN 60068-2-14, EN 60068-2-2, EN 60068-2-30, EN 60068-2-78	EN 60068-2-1, EN 60068-2-14, EN 60068-2-2, EN 60068-2-30, EN 60068-2-78	EN 50125-1, EN 50125-3, EN 50155, EN 60068-2-1, EN 60068-2-14, EN 60068-2-2
Ambient temperature			
in accordance with the standard	EN 60068-2-14	EN 60068-2-14	EN 50155
Temperature range	0 - 60 °C	-40 - 70 °C	-40 - 70 °C
Max. temperature in accordance with UL	60 °C	60 °C	–
in accordance with the standard	–	–	EN 50125-1
Temperature range	–	–	-40 ... +70 °C
in accordance with the standard	–	–	EN 50125-3
Temperature range	–	–	-40 ... +70 °C
Storage temperature			
in accordance with the standard	EN 60068-2-1/-2	EN 60068-2-1/-2	EN 60068-2-1/-2
Temperature range	-40 - 70 °C	-40 - 70 °C	-40 - 70 °C
Climatic suitability			
in accordance with the standard	EN 60068-2-78	EN 60068-2-78	EN 60068-2-78
Humidity	93 % r. h. at 40 °C	93 % r. h. at 40 °C	97 % r. h. at 40 °C
Condensation during operation	Not permitted	EN 60068-2-30, only with protective extra-low voltage, transient	EN 50155, EN 60068-2-30, only with protective extra-low voltage, transient
Max. operating height above SL	2000 m	5000 m	2000 m

Environmental data	312225	314225	315225
Max. operating height above sea level in accordance with EN 81-1, EN 81-2 and EN 115-1	2000 m	2000 m	–
EMC	EN 12015, EN 12016, EN 61000-6-2, EN 61000-6-4, EN 61131-2 (Zone B)	EN 12015, EN 12016, EN 61000-6-2, EN 61000-6-4, EN 61131-2 (Zone B)	EN 50121-3-2, EN 50124-1, EN 61000-6-2, EN 61000-6-4
Vibration			
in accordance with the standard	EN 60068-2-6	EN 60068-2-6	–
Frequency	10 - 150 Hz	10 - 150 Hz	–
Acceleration	10 m/s²	10 m/s²	–
Broadband noise			
in accordance with the standard	–	EN 60068-2-64	–
Frequency	–	5 - 500 Hz	–
Acceleration	–	19 m/s² eff.	–
in accordance with the standard	–	–	EN 61373
Frequency	–	–	5 ... 150 Hz
Acceleration	–	–	7,9 m/s² eff.
in accordance with the standard	–	–	EN 50125-3
Frequency	–	–	5 - 2.000 Hz
Acceleration	–	–	2,3 m/s² eff.
Shock stress			
in accordance with the standard	EN 60068-2-27	EN 60068-2-27	–
Number of shocks	6	6	–
Acceleration	150 m/s²	150 m/s²	–
Duration	11 ms	11 ms	–
in accordance with the standard	–	–	EN 50125-3
Number of shocks	–	–	6
Acceleration	–	–	20 m/s²
Duration	–	–	11 ms
in accordance with the standard	–	–	EN 61373
Number of shocks	–	–	6
Acceleration	–	–	50 m/s²
Duration	–	–	30 ms

Environmental data	312225	314225	315225
Airgap creepage			
in accordance with the standard	EN 61131-2	EN 61131-2	–
Overvoltage category	II	II	–
Pollution degree	2	2	–
in accordance with the standard	–	–	EN 50124-1
Overvoltage category	–	–	OV2
Pollution degree	–	–	PD2
Protection type			
in accordance with the standard	EN 60529	EN 60529	–
Housing	IP20	IP20	–
Terminals	IP20	IP20	–
in accordance with the standard	–	–	EN 60529
Mounting area	–	–	IP51
Housing	–	–	IP20
Terminals	–	–	IP20
Mounting area (e.g. control cabinet)	IP54	IP54	–
Potential isolation	312225	314225	315225
Potential isolation between	Relay contact and module supply	Relay contact and module supply	Relay contact and module supply
Type of potential isolation	Protective separation	Protective separation	Protective separation
Rated surge voltage in operating heights up to max. 2000 m	6000 V	6000 V	6000 V
Rated surge voltage in operating heights up to max. 5000 m	–	4000 V	–
Potential isolation between	Relay contact and periphery supply	Relay contact and periphery supply	Relay contact and periphery supply
Type of potential isolation	Protective separation	Protective separation	Protective separation
Rated surge voltage in operating heights up to max. 2000 m	6000 V	6000 V	6000 V
Rated surge voltage in operating heights up to max. 5000 m	–	4000 V	–
Potential isolation between	Relay contact and C-rail	Relay contact and C-rail	Relay contact and C-rail
Type of potential isolation	Protective separation	Protective separation	Protective separation
Rated surge voltage in operating heights up to max. 2000 m	6000 V	6000 V	6000 V
Rated surge voltage in operating heights up to max. 5000 m	–	4000 V	–

Potential isolation	312225	314225	315225
Potential isolation between	Relay contact 1 and relay contact 2	Relay contact 1 and relay contact 2	Relay contact 1 and relay contact 2
Type of potential isolation	Protective separation	Protective separation	Protective separation
Rated surge voltage in operating heights up to max. 2000 m	6000 V	6000 V	6000 V
Rated surge voltage in operating heights up to max. 5000 m	–	4000 V	–
Mechanical data	312225	314225	315225
Mechanical life	10,000,000 cycles	10,000,000 cycles	10,000,000 cycles
Material			
Bottom	PC	PC	PC
Front	PC	PC	PC
Coding	PA	PA	PA
Mounting type	plug-in	plug-in	plug-in
Dimensions			
Height	76 mm	76 mm	76 mm
Width	25,2 mm	25,2 mm	25,2 mm
Depth	60,2 mm	60,2 mm	60,2 mm
Weight	90 g	91 g	93 g
Mechanical coding			
Type	H	H	H
Colour	Yellow	Yellow	Yellow

Where standards are undated, the 2022-01 latest editions shall apply.

Further information about the switching capability is available in the service life graphs.

8.1 Safety characteristic data



NOTICE

You must comply with the safety characteristic data in order to achieve the required safety level for your plant/machine.

Operating mode	EN ISO 13849-1: 2015 PL	EN ISO 13849-1: 2015 Category	EN IEC 62061 SIL CL/ maximum SIL	EN IEC 62061 PFH _D [1/h]	EN/IEC 61511 SIL	EN/IEC 61511 PFD	EN ISO 13849-1: 2015 T _M [year]
1-channel	PL c	Cat. 1	-	7,60E-08	-	6,66E-03	20
2-channel	PL e	Cat. 4	SIL CL 3	7,78E-10	SIL 3	1,34E-06	20

Explanatory notes for the safety-related characteristic data:

- ▶ Safety characteristic data in accordance with EN IEC 62061 and EN/IEC 61511 was calculated based on EN/IEC 61508.
- ▶ T_M is the maximum mission time in accordance with EN ISO 13849-1. The value also applies as the retest interval in accordance with EN/IEC 61508-6 and EN/IEC 61511 and as the proof test interval and mission time in accordance with EN IEC 62061.

All the units used within a safety function must be considered when calculating the safety characteristic data.



INFORMATION

A safety function's SIL/PL values are **not** identical to the SIL/PL values of the units that are used and may be different. We recommend that you use the PAScal software tool to calculate the safety function's SIL/PL values.



CAUTION!

It is essential to consider the relay's service life graphs. The relay outputs' safety-related characteristic data is only valid if the values in the service life graphs are met.

The PFH value depends on the switch frequency and the load of the relay output. If the service life graphs are not accessible, the stated PFH value can be used irrespective of the switch frequency and the load, as the PFH value already considers the relay's B10d value as well as the failure rates of the other components.

8.2 Service life graphs

The service life graphs indicate the number of cycles from which failures due to wear must be expected. The wear is mainly caused by the electrical load; the mechanical load is negligible.

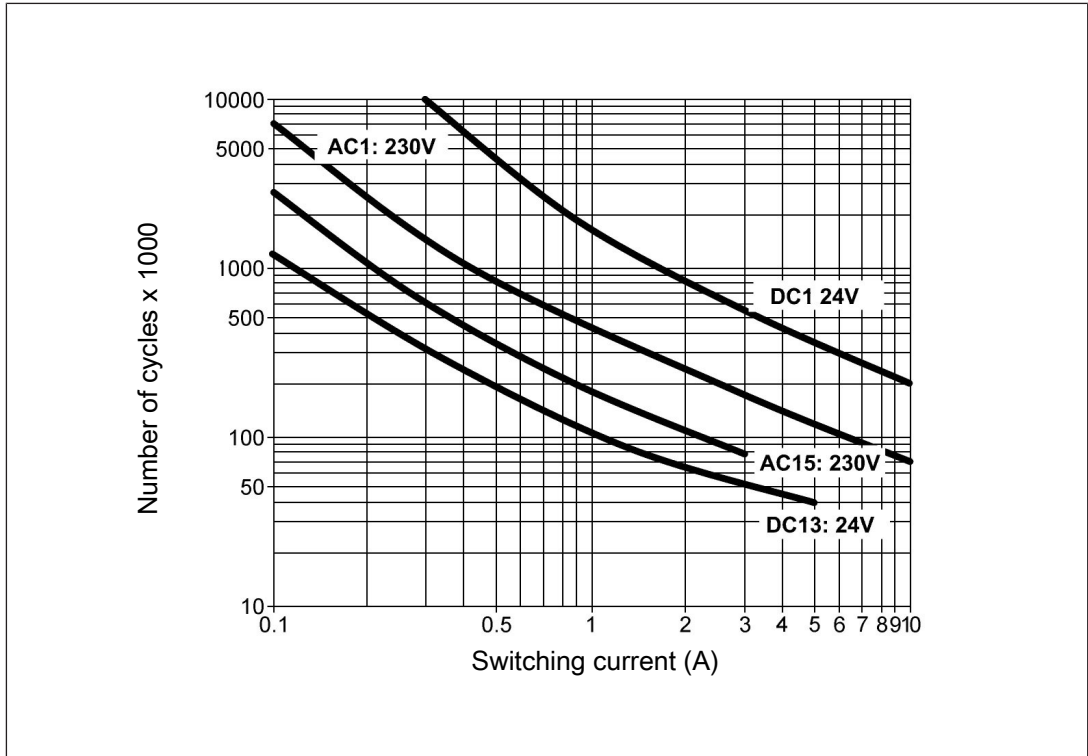

Fig.: Service life graph / Switching capability 24 VDC / 250 VAC

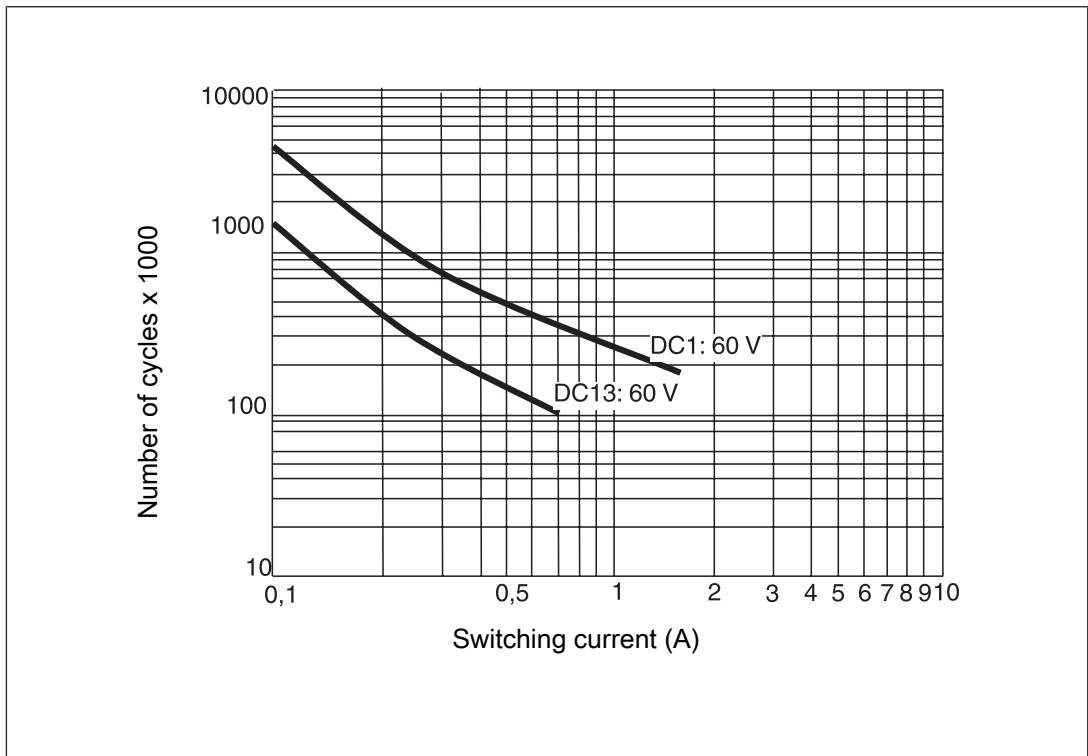

Fig.: Service life graph / Switching capability 60 VDC

Example

- ▶ Inductive load: 0.2 A
- ▶ Utilisation category: AC15
- ▶ Contact service life: 1 000 000 cycles

Provided the application to be implemented requires fewer than 1 000 000 cycles, the PFH value (see [Technical details \[📖 32\]](#)) can be used in the calculation.

To increase the service life, sufficient spark suppression must be provided on all relay contacts. With capacitive loads, any power surges that occur must be noted. With DC contactors, use flywheel diodes for spark suppression.

We recommend you use semiconductor outputs to switch 24 VDC loads.

9 Supplementary data

9.1 Permitted operating height

The values stated in the technical details apply to the use of the device in operating heights up to max. 2000 m above SL. When used at higher levels, restrictions of the ambient temperature (standard IEC 61131-2) must be taken into account.

Operating height above SL [m]	Multiplication factors for the devices' ambient temperature
0 ... 2000	1.0
3000	0.9
4000	0.8
5000	0.7

10 Order reference

10.1 Product

Product type	Features	Order no.
PSSu E F 2DOR 8	Electronic module, base type	312225
PSSu E F 2DOR 8-T	Electronic module, T-type	314225
PSSu E F 2DOR 8-R	Electronic module, R-type	315225

10.2 Accessories

Base modules

Product type	Features	Order no.
PSSu BP 2/16 S	Base module without C-rail with screw terminals	312628
PSSu BP 2/16 S-T	Base module without C-rail with screw terminals, T-type	314628
PSSu BP 2/16 C	Base module without C-rail with cage clamp terminals	312629
PSSu BP 2/16 C-T	Base module without C-rail with cage clamp terminals, T-type	314629
PSSu BP-C 2/16 S	Base module with C-rail and screw terminals	312630
PSSu BP-C 2/16 S-T	Base module with C-rail and screw terminals, T-type	314630
PSSu BP-C 2/16 C	Base module with C-rail and cage clamp terminals	312631
PSSu BP-C 2/16 C-T	Base module with C-rail and cage clamp terminals, T-type	314631

11 EC declaration of conformity for PSSu E F 2DOR 8 and PSSu E F 2DOR 8-T

This product/these products meet the requirements of the directive 2006/42/EC on machinery of the European Parliament and of the Council. The complete EC Declaration of Conformity is available on the Internet at www.pilz.com/downloads.

Representative: Pilz GmbH & Co. KG, Felix-Wankel-Str. 2, 73760 Ostfildern, Germany

12 UKCA-Declaration of Conformity for PSSu E F 2DOR 8 and PSSu E F 2DOR 8-T

This product(s) complies with following UK legislation: Supply of Machinery (Safety) Regulation 2008.

The complete UKCA Declaration of Conformity is available on the Internet at www.pilz.com/downloads.

Representative: Pilz Automation Technology, Pilz House, Little Colliers Field, Corby, Northamptonshire, NN18 8TJ United Kingdom, eMail: mail@pilz.co.uk

► Support

Technical support is available from Pilz round the clock.

Americas

Brazil

+55 11 97569-2804

Canada

+1 888 315 7459

Mexico

+52 55 5572 1300

USA (toll-free)

+1 877-PILZUSA (745-9872)

Asia

China

+86 400-088-3566

Japan

+81 45 471-2281

South Korea

+82 31 778 3300

Australia and Oceania

Australia

+61 3 95600621

New Zealand

+64 9 6345350

Europe

Austria

+43 1 7986263-444

Belgium, Luxembourg

+32 9 3217570

France

+33 3 88104003

Germany

+49 711 3409-444

Ireland

+353 21 4804983

Italy, Malta

+39 0362 1826711

Scandinavia

+45 74436332

Spain

+34 938497433

Switzerland

+41 62 88979-32

The Netherlands

+31 347 320477

Türkiye

+90 216 5775552

United Kingdom

+44 1536 462203

You can reach our international hotline on:

+49 711 3409-222

support@pilz.com

Pilz develops environmentally-friendly products using ecological materials and energy-saving technologies. Offices and production facilities are ecologically designed, environmentally-aware and energy-saving. So Pilz offers sustainability, plus the security of using energy-efficient products and environmentally-friendly solutions.



We are represented internationally. Please refer to our homepage www.pilz.com for further details or contact our headquarters.

Headquarters: Pilz GmbH & Co. KG, Felix-Wankel-Straße 2, 73760 Ostfildern, Germany
Telephone: +49 711 3409-0, E-Mail: info@pilz.com, Internet: www.pilz.com

PILZ
THE SPIRIT OF SAFETY

CECE[®], CHRE[®], CMSE[®], INDUSTRIAL P[®], Leansafe[®], Myzei[®], PAS4000[®], PASscal[®], PASconfig[®], Pilz[®], PIT[®], PVMprimo[®], PVMprotego[®], PMCiendo[®], PMD[®], PMI[®], PNOZ[®], Primo[®], PSEN[®], PSEN[®], PSS[®], PVIS[®], SafetyBUS p[®], SafetyNET p[®], THE SPIRIT OF SAFETY[®] are registered and protected trademarks of Pilz GmbH & Co. KG in some countries. We would point out that product features may vary from the details stated in this document, depending on the status at the time of publication and the scope of the equipment. We accept no responsibility for the validity, accuracy and entirety of the text and graphics presented in this information. Please contact our Technical Support if you have any questions.

21334-EN-15, 2023-08 Printed in Germany
© Pilz GmbH & Co. KG, 2019