



▶ PSSu E S 4DO 0.5-(T)D

PILZ

THE SPIRIT OF SAFETY

Operating Manual-21951-EN-09

- Decentralised system PSSuniversal I/O



This document is the original document.

Where unavoidable, for reasons of readability, the masculine form has been selected when formulating this document. We do assure you that all persons are regarded without discrimination and on an equal basis.

All rights to this documentation are reserved by Pilz GmbH & Co. KG. Copies may be made for the user's internal purposes. Suggestions and comments for improving this documentation will be gratefully received.

Pilz®, PIT®, PMI®, PNOZ®, Primo®, PSEN®, PSS®, PVIS®, SafetyBUS p®, SafetyEYE®, SafetyNET p®, the spirit of safety® are registered and protected trademarks of Pilz GmbH & Co. KG in some countries.



SD means Secure Digital

1	Introduction	5
1.1	Validity of documentation	5
1.1.1	Retaining the documentation	5
1.1.2	Terminology: System environment A and B	5
1.2	Definition of symbols	6
2	Overview	7
2.1	Module structure	7
2.2	Module features	7
2.3	Front view	8
3	Safety	10
3.1	Intended use	10
3.2	Safety regulations	11
3.2.1	Use of qualified personnel	11
3.2.2	Warranty and liability	11
3.2.3	Disposal	11
4	Function description	12
4.1	Block diagram	12
4.2	Module features	12
4.2.1	Functions	12
4.2.2	Integrated protection mechanisms	13
4.2.3	Reaction times	13
4.3	Configuration	14
4.3.1	PSSu assignment in system environment A	14
4.3.1.1	Addresses in the process image	14
4.3.1.2	Status byte	14
4.3.2	PSSu assignment in system environment B	15
5	Installation	16
5.1	General installation guidelines	16
5.1.1	Dimensions	16
5.2	Installing the base module	18
5.3	Inserting and removing an electronic module	19
5.3.1	Inserting an electronic module	20
5.3.2	Removing an electronic module	21
5.3.3	Changing an electronic module during operation	21
6	Wiring	22
6.1	General wiring guidelines	22
6.1.1	Mechanical connection of the base modules	22
6.2	Terminal configuration	24
6.3	Connecting the module	27
7	Operation	28
7.1	Messages	28
7.2	Display elements	29

7.2.1	Display elements for module diagnostics	29
7.2.2	Display elements for output status	29
8	Technical details	30
9	Supplementary data	33
9.1	Permitted operating height	33
10	Order reference	34
10.1	Product	34
10.2	Accessories	34

1 Introduction

1.1 Validity of documentation

This documentation is valid for the products PSSu E S 4DO 0.5-D and PSSu E S 4DO 0.5-TD. It is valid until new documentation is published.

This operating manual explains the function and operation, describes the installation and provides guidelines on how to connect the product.

The module PSSu E S 4DO 0.5-TD is suitable for use where there are increased environmental requirements (see Technical Details).

1.1.1 Retaining the documentation

This documentation is intended for instruction and should be retained for future reference.

1.1.2 Terminology: System environment A and B

The PSSu system can be used in two different system environments. The module's application area is described in the chapter "Intended Use" of the manual.

The distinction is made between

- ▶ PSSu in system environment A
- ▶ PSSu in system environment B

The distinction is based on the application area of the PSSu system.

PSSu in system environment A may be used in the

- ▶ Decentralised system PSSu I/O
- ▶ **Not** in the automation system PSS 4000

PSSu in system environment B may be used in the

- ▶ Automation system PSS 4000, e.g. with
 - Decentralised system PSSu I/O with SafetyNET p
 - Control system PSSu PLC
 - Control system PSSu multi

1.2 Definition of symbols

Information that is particularly important is identified as follows:



DANGER!

This warning must be heeded! It warns of a hazardous situation that poses an immediate threat of serious injury and death and indicates preventive measures that can be taken.



WARNING!

This warning must be heeded! It warns of a hazardous situation that could lead to serious injury and death and indicates preventive measures that can be taken.



CAUTION!

This refers to a hazard that can lead to a less serious or minor injury plus material damage, and also provides information on preventive measures that can be taken.



NOTICE

This describes a situation in which the product or devices could be damaged and also provides information on preventive measures that can be taken. It also highlights areas within the text that are of particular importance.



INFORMATION

This gives advice on applications and provides information on special features.

2 Overview

2.1 Module structure

A module consists of

- ▶ Electronic module and
- ▶ Base module with
 - Screw terminals or
 - Cage clamp terminals

The base modules are the carrier units for the electronic modules and are used to connect the field wiring. The electronic modules are inserted on to the base modules and determine the module's function.

Details of the base modules that can be used are available in the chapter entitled “Intended Use”.

2.2 Module features

The product has the following features:

- ▶ 4 Digital outputs
 - Semiconductor technology
 - Single-pole
 - Positive-switching
 - Current load capacity per output: 0,5 A
 - Short circuit-proof
 - Overload-proof
- ▶ LEDs for:
 - Switch status of each output
 - Module error
- ▶ The module provides advanced diagnostic data.
- ▶ Optional access to the advanced diagnostic data in the process image (system environment A only)
- ▶ For standard applications in system environment A and B
- ▶ T-type:
 - PSSu E S 4DO 0.5-TD: for increased environmental requirements

2.3 Front view

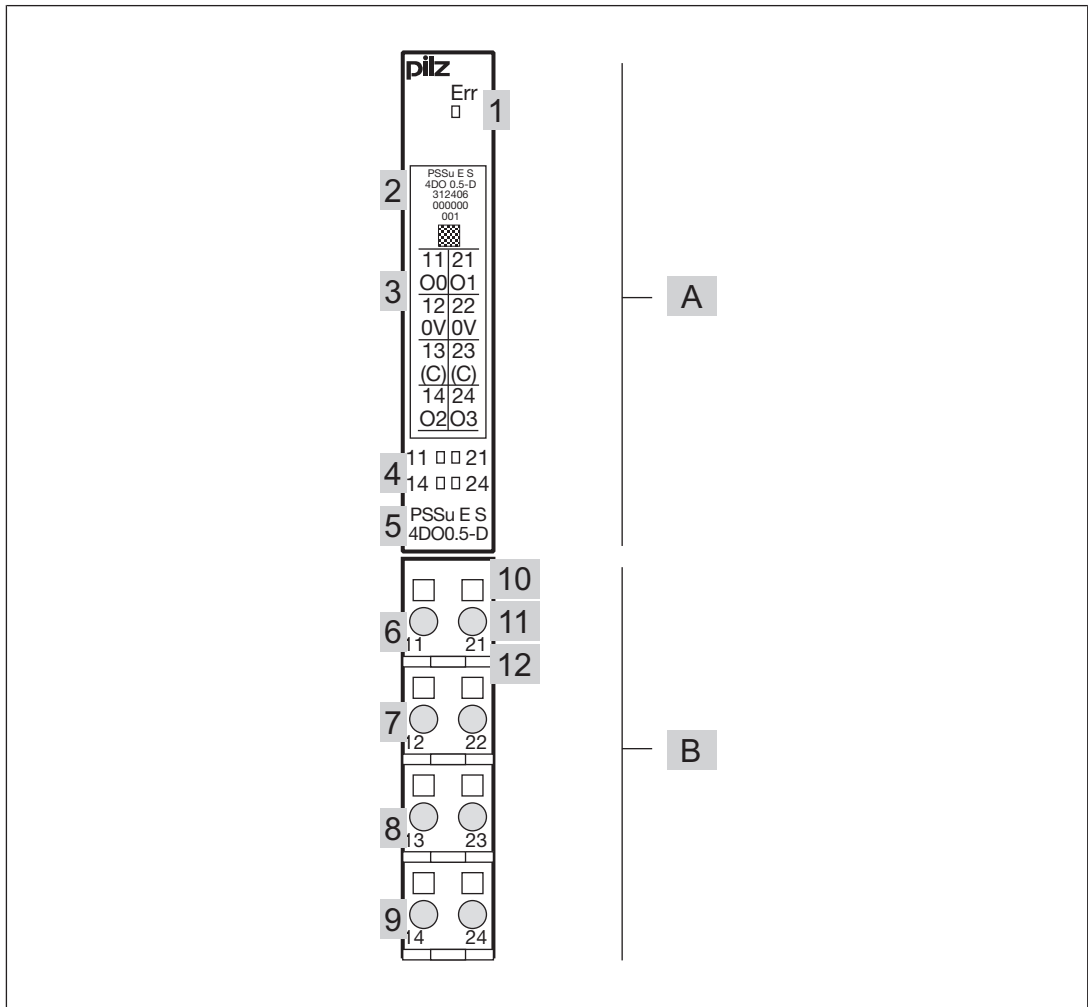

Legend:

- ▶ A: Electronic module
- ▶ B: Base module
- ▶ 1: LED for module diagnostics
- ▶ 2: Labelling strip with:
 - Name of electronic module
 - Order number
 - Serial number
 - Hardware version number
 - 2D code
- ▶ 3: Labelling strip for the terminal configuration on the base module
- ▶ 4: Status LEDs
- ▶ 5: Name of electronic module
- ▶ 6: Connection level 1
- ▶ 7: Connection level 2
- ▶ 8: Connection level 3

- ▶ 9: Connection level 4
- ▶ 10: Square mounting holes (connection levels 1, 2, 3 and 4)
 - With screw to loosen/tighten the screw terminal on base modules with screw terminals
 - With mechanism to operate the cage clamp on base modules with cage clamp terminals
- ▶ 11: Round connection holes (connection levels 1, 2, 3 and 4) for connecting the signal lines
- ▶ 12: Mounting slot for colour marker to label the connection level (connection levels 1, 2, 3 and 4)

3 Safety

3.1 Intended use

The module may be used for standard applications in system environment A and B.

The module provides type 1 outputs in accordance with IEC 61131-2. It may be used to switch:

- ▶ Resistive loads
- ▶ Inductive loads
- ▶ Capacitive loads

The module PSSu E S 4DO 0.5-TD is suitable for use where there are increased environmental requirements (see Technical Details).

With reference to the standard IEC 61131-2 the values stated in the technical details for ambient temperature are reduced at heights >2000 m operating height above sea level (see [Supplementary data \[33\]](#)).

Intended use includes making the electrical installation EMC-compliant. Please refer to the guidelines stated in the "PSSuniversal Installation Manual". The module is designed for use in an industrial environment. It is not suitable for use in a domestic environment, as this can lead to interference.

The following is deemed improper use in particular:

- ▶ Any component, technical or electrical modification to the module
- ▶ Use of the module outside the areas described in this manual
- ▶ Any use of the module that is not in accordance with the technical details.



INFORMATION

The module is supported by:

- ▶ PSSuniversal Configurator and PSSuniversal Assistant from Version 1.6.0
- ▶ PAS4000 from version 1.8.0
 - We recommend that you always use the latest version (download from www.pilz.de).

The PSSu E S 4DO 0.5-D module may be used in conjunction with the following base modules:

- ▶ PSSu BP 1/8 S
- ▶ PSSu BP 1/8 C
- ▶ PSSu BP-C 1/8 S
- ▶ PSSu BP-C 1/8 C
- ▶ PSSu BP 1/12 S
- ▶ PSSu BP 1/12 C
- ▶ PSSu BP-C1 1/12 S
- ▶ PSSu BP-C1 1/12 C

The PSSu E S 4DO 0.5-TD module may be used in conjunction with the following base modules:

- ▶ PSSu BP 1/8 S-T
- ▶ PSSu BP 1/8 C-T
- ▶ PSSu BP-C 1/8 S-T
- ▶ PSSu BP-C 1/8 C-T
- ▶ PSSu BP 1/12 S-T
- ▶ PSSu BP 1/12 C-T
- ▶ PSSu BP-C1 1/12 S-T
- ▶ PSSu BP-C1 1/12 C-T

3.2 Safety regulations

3.2.1 Use of qualified personnel

The products may only be assembled, installed, programmed, commissioned, operated, maintained and decommissioned by persons who are competent to do so.

A competent person is a qualified and knowledgeable person who, because of their training, experience and current professional activity, has the specialist knowledge required. To be able to inspect, assess and operate devices, systems and machines, the person has to be informed of the state of the art and the applicable national, European and international laws, directives and standards.

It is the company's responsibility only to employ personnel who

- ▶ Are familiar with the basic regulations concerning health and safety / accident prevention,
- ▶ Have read and understood the information provided in the section entitled Safety
- ▶ Have a good knowledge of the generic and specialist standards applicable to the specific application.

3.2.2 Warranty and liability

All claims to warranty and liability will be rendered invalid if

- ▶ The product was used contrary to the purpose for which it is intended,
- ▶ Damage can be attributed to not having followed the guidelines in the manual,
- ▶ Operating personnel are not suitably qualified,
- ▶ Any type of modification has been made (e.g. exchanging components on the PCB boards, soldering work etc.).

3.2.3 Disposal

- ▶ In safety-related applications, please comply with the mission time T_M in the safety-related characteristic data.
- ▶ When decommissioning, please comply with local regulations regarding the disposal of electronic devices (e.g. Electrical and Electronic Equipment Act).

4 Function description

4.1 Block diagram

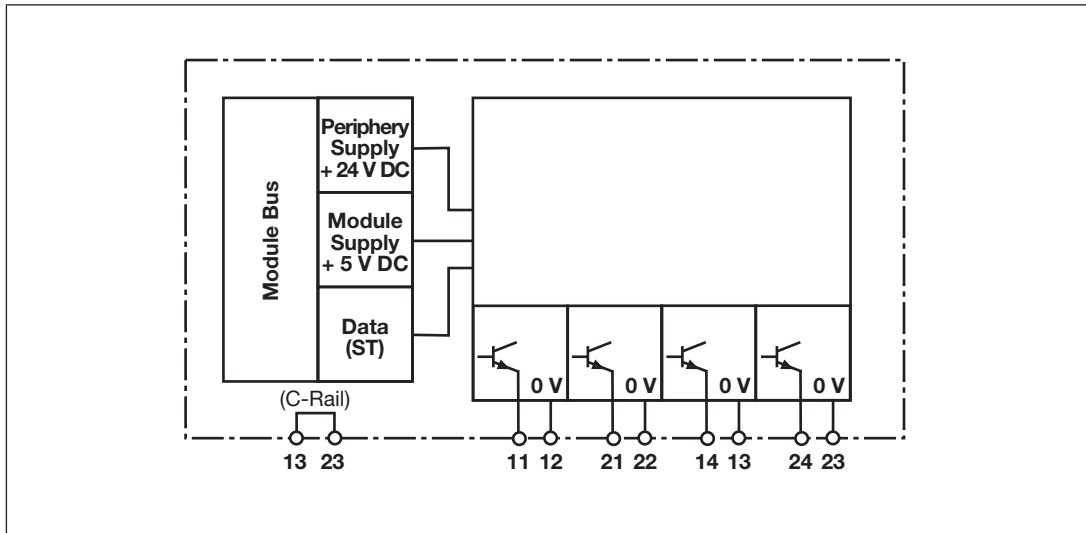

4.2 Module features

4.2.1 Functions

Module supply

- ▶ The module supply provides the module with voltage.

Signals at the output

- ▶ "0" signal (0 V) at the output:
 - Output is high impedance
 - No current to the load
- ▶ "1" signal (+24 V) at the output:
 - Output is low impedance
 - Current is supplied to the load

Periphery supply

- ▶ The module routes the periphery supply from the module bus to the base module terminals.
- ▶ The periphery supply is used to supply the outputs.

Outputs

- ▶ The head module sets the output status via the module bus.

The module provides advanced diagnostic data, which is also available in a status byte in the ST-PII (not in system environment B):

- ▶ Output overload/short circuit
- ▶ Excess module temperature

Permitted capacitive load based on output current

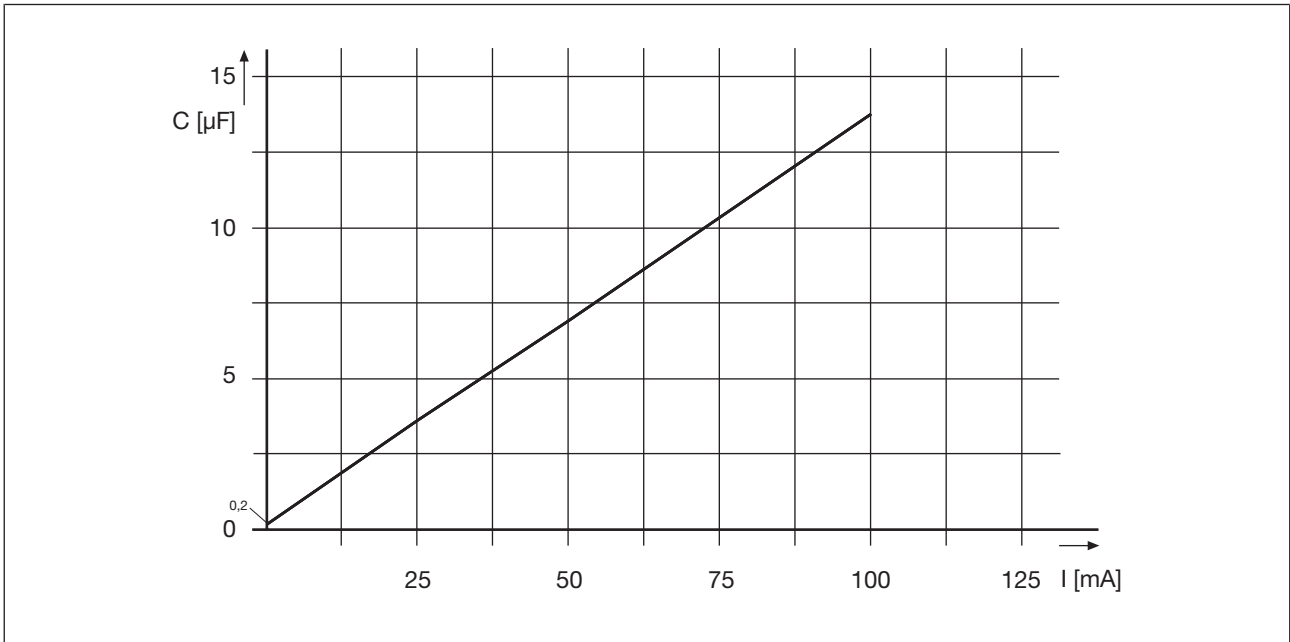

4.2.2 Integrated protection mechanisms

When the PSSu E F PS1(-T) or PSSu E F PS2(-T)(-R) is used to supply the system, the module supply is buffered for 20 ms if the supply voltage is interrupted.

The module provides the following diagnostic data:

- ▶ Start-up error
- ▶ Configuration error
- ▶ ST communication error
- ▶ Bus termination error
- ▶ Output overload
- ▶ Temperature error: too warm
- ▶ Temperature error: too hot

4.2.3 Reaction times

Information on the reaction times of the outputs can be found in the PSSuniversal System Description.

4.3 Configuration

4.3.1 PSSu assignment in system environment A

It is not necessary to configure ST outputs in the PSSuniversal Configurator on the PSS WIN-PRO system software. Overload detection and temperature monitoring can be configured: The entries in the status byte can be deactivated.

The ST process image can be optimised by combining adjacent bits of the same type into bytes.

Further information on configuration is available in the PSSuniversal Configurator's online help.

4.3.1.1 Addresses in the process image

The module occupies 4 consecutive bit addresses for the outputs in the process image of outputs. If the status byte is activated, it occupies an additional 8 consecutive bit addresses in the process image of inputs.

Configuration	SafetyBUS p	Standard bus system	
	FS-PIO	ST-PII	ST-PIO
Without status byte	- - -	- - -	4 Bit
With status byte ("S")	- - -	8 Bit	4 Bit

4.3.1.2 Status byte

The status byte contains the information on overload and overtemperature.

Structure and contents of the status byte:

Bit number	Signal	Meaning
0	0	No overload on output 0
	1	Overload on output 0
1	0	No overload on output 1
	1	Overload on output 1
2 ⁽¹⁾	0	No overload on output 2
	1	Overload on output 2
3 ⁽¹⁾	0	No overload on output 3
	1	Overload on output 3
4	0	No temperature error
	1	Temperature error: too warm
5	0	Switch-off temperature not reached
	1	Temperature error: too hot, outputs switch off
6	0	Reserved
	1	Reserved

Bit number	Signal	Meaning
7	0	Reserved
	1	Reserved

⁽¹⁾ Only on modules with four outputs

4.3.2 PSSu assignment in system environment B

Data access is via pre-defined I/O data types:

I/O data name	I/O data type	I/O data element	Meaning
O0(11), O1(21), O2(14), O3(24)	ST_O_DO	Data: BOOL	Output data O0 ... O3

The status byte is not available in the process image.

5 Installation

5.1 General installation guidelines

Please also refer to the PSSuniversal Installation Manual.



NOTICE

Damage due to electrostatic discharge!

Electrostatic discharge can damage components. Ensure against discharge before touching the product, e.g. by touching an earthed, conductive surface or by wearing an earthed armband.

5.1.1 Dimensions

Base modules with four connection levels:

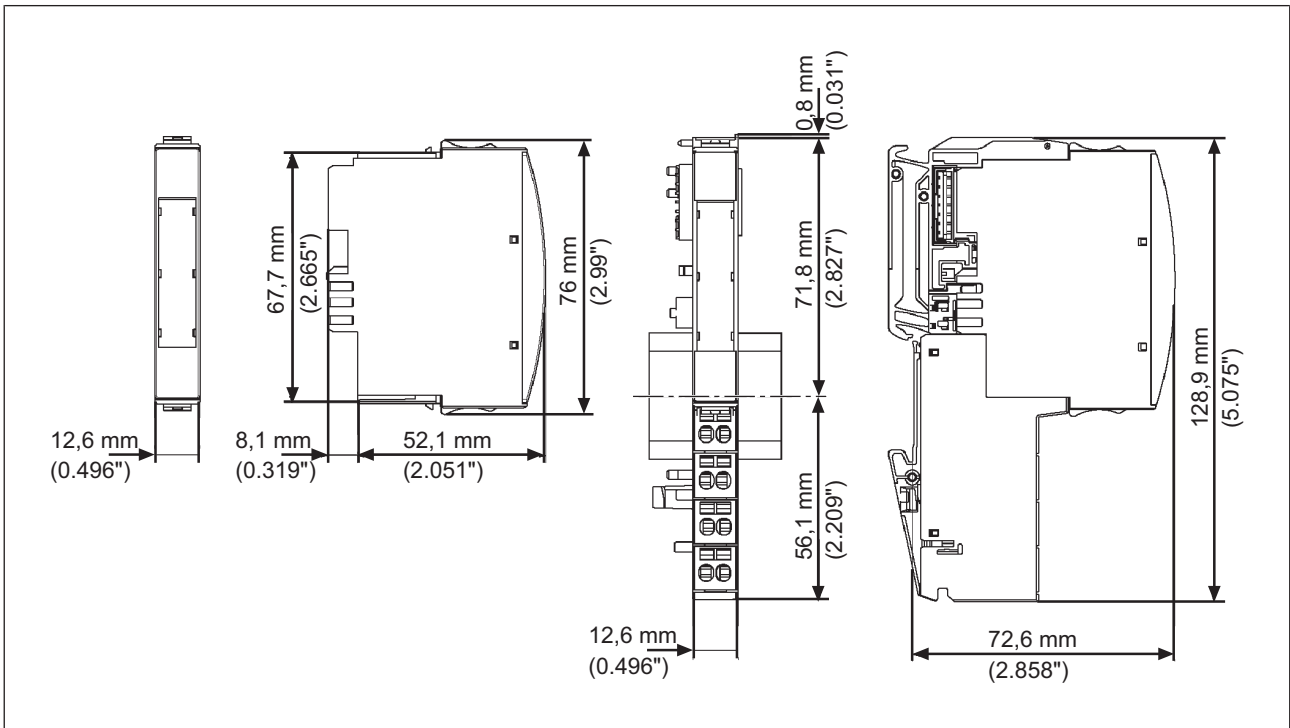

Base modules with six connection levels:

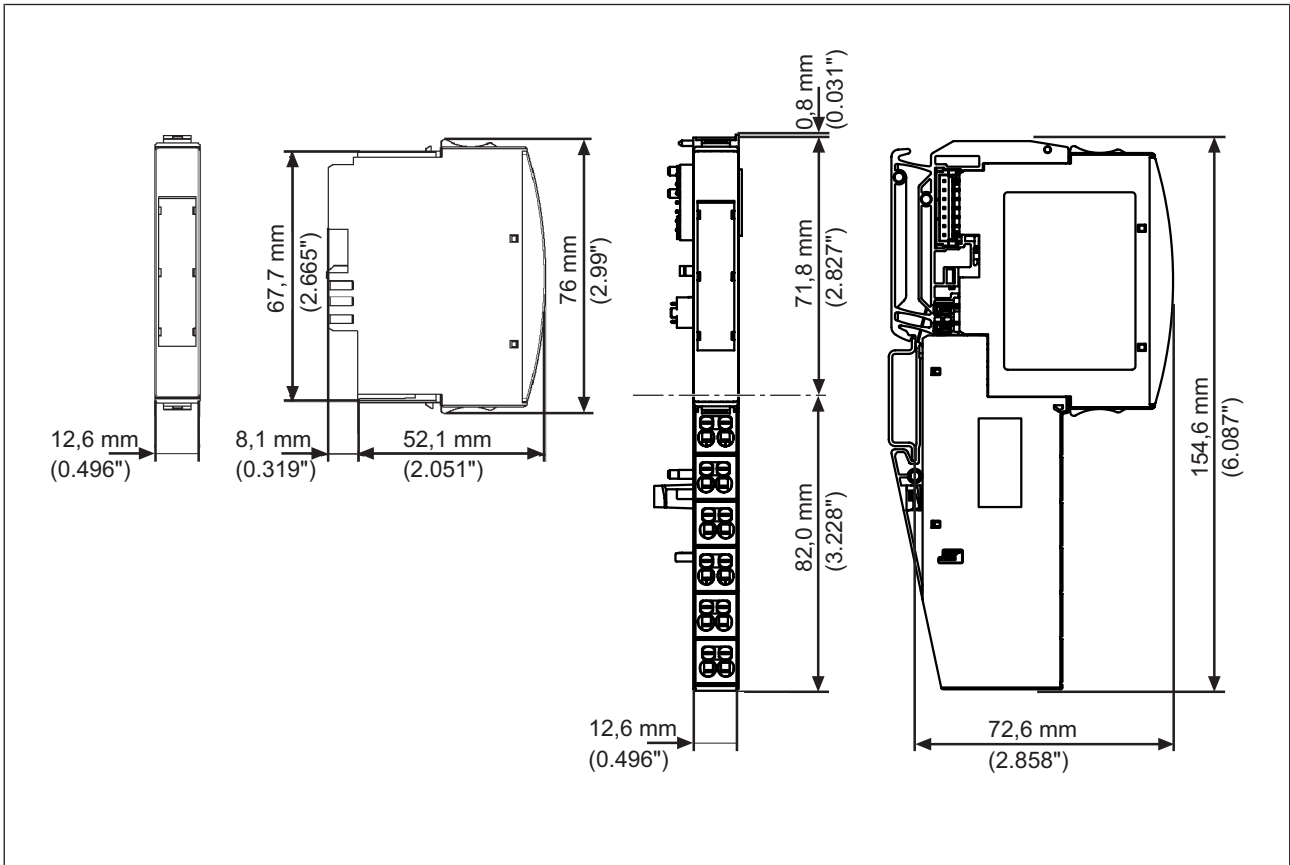

5.2 Installing the base module

Prerequisite:

- ▶ The head module must be installed.
- ▶ If the head module does not have an integrated power supply, a supply voltage module must be installed to the right of the head module.

Please note:

- ▶ For mechanical reasons it is not possible to mix base modules with screw terminals and base modules with cage clamp terminals.
- ▶ All contacts should be protected from contamination.
- ▶ The mechanics of the base modules are designed for 50 plug in/out cycles.

Procedure:

- ▶ We recommend that you wire up the base modules before inserting the electronic modules.
- ▶ Slot the groove on the base module on to the mounting rail from below [1].
- ▶ Push the base module back [2] until you hear it lock into position.
- ▶ On the mounting rail, slide the base module to the left until you hear the two lateral mounting hooks on the adjacent module lock into position [3].

Schematic representation:

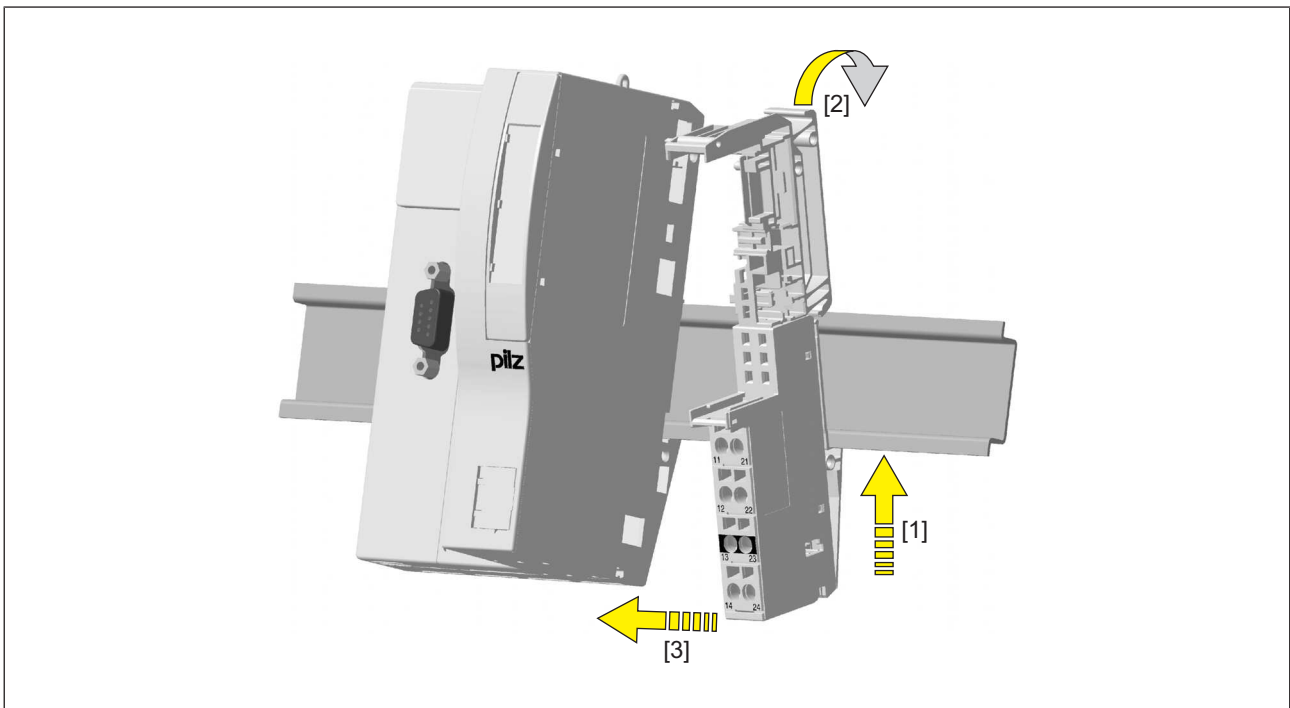

5.3 Inserting and removing an electronic module

Please note:

- ▶ Only insert on to base modules that are already installed.
- ▶ Preferably these base modules should be ready wired.
- ▶ Electronic modules with outputs may only be inserted and removed when the load is switched off. Unforeseeable error reactions may be triggered if modules are inserted and removed under load.
- ▶ When an electronic module is plugged into a base module for the first time, one part of the coding element remains on the electronic module, while its counterpart is fixed on to the base module. This is how the base module is coded.
- ▶ The mechanics of the electronic modules are designed for 50 plug in/out cycles.

5.3.1 Inserting an electronic module

Procedure:

- ▶ The electronic module must audibly lock into position [1].
- ▶ Mark the electronic module using the labelling strips [2].

Schematic representation:

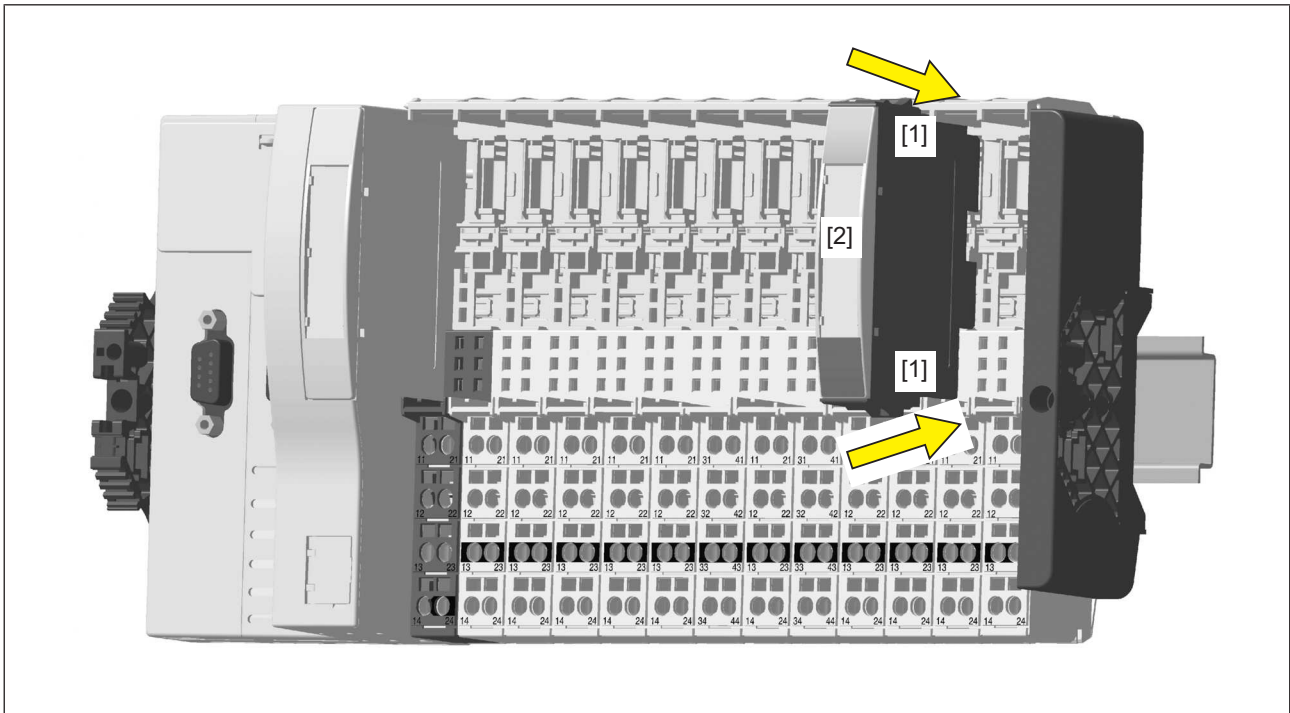

5.3.2 Removing an electronic module

Procedure:

- ▶ Press the locking mechanisms [1] together simultaneously.
- ▶ Pull out the electronic module [2].

Schematic representation:

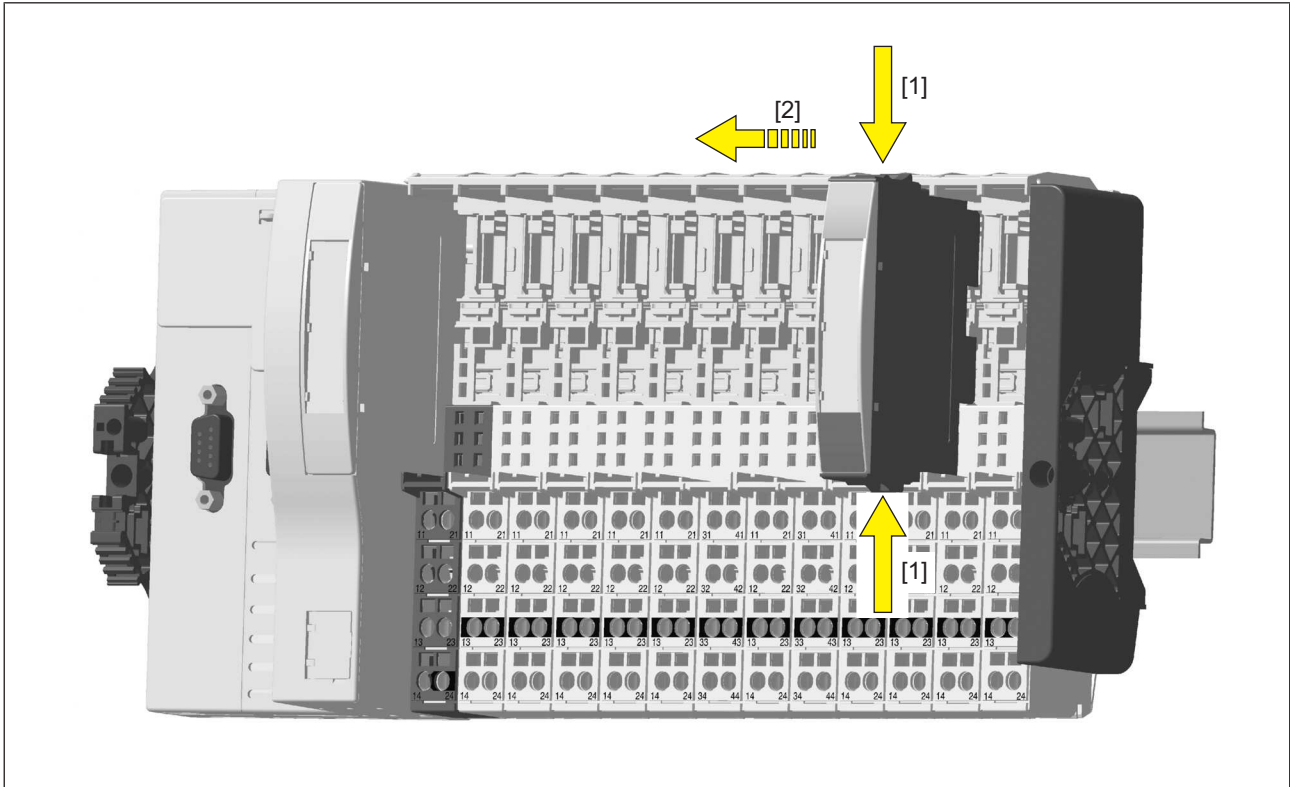

5.3.3 Changing an electronic module during operation

It is possible to change an electronic module during operation. The configuration data is retained when a module is changed.

Effects:

- ▶ System environment A:
 - In the event of a potential FS communication error, the FS section of the PSSu system and all relevant I/O-Groups (SafetyBUS p) switch to a STOP condition.
- ▶ System environment B:
 - All FS hardware outputs on the PSSu system switch to a safe condition.
 - The substitute values are used for the modules' FS outputs, with Valid Bits = FALSE.



CAUTION!

Sparking can cause interference and errors!

Only change the module when the load is switched off!

6 Wiring

6.1 General wiring guidelines

Please note:

- ▶ The actuators may be connected using unshielded cables.
- ▶ The outputs do not need suppression for inductive loads.
- ▶ Use copper wiring.
- ▶ The terminal configuration as stated on the front plate applies for base modules with C-rail. The terminal configuration as stated in the technical documentation applies for all other base modules.

6.1.1 Mechanical connection of the base modules

Procedure:

- ▶ Use a flat blade screwdriver (DIN 5264-A)!

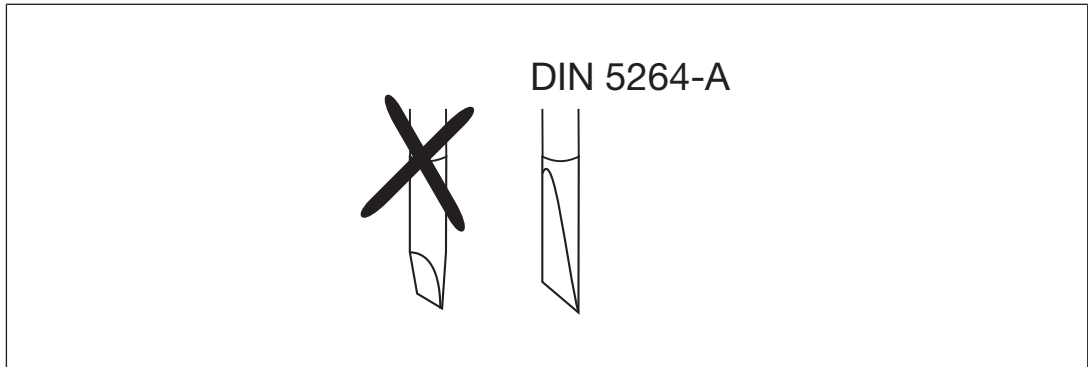

- ▶ Strip the wire back 8 mm.
- ▶ If necessary, label the connection level with a colour marker [3].
- ▶ Base module with screw terminals:
 - Use a screwdriver to loosen the screw on the screw terminal [1]
 - Insert the stripped cable into the round fixing hole [2], as far as it will go.
 - Tighten up the screw on the screw terminal.
 - Check that the cable is firmly seated.
- ▶ Base module with cage clamp terminals:
 - Insert the screwdriver [4] into the square hole [1].
 - Insert the stripped cable into the round fixing hole [2], as far as it will go [5].
 - Pull out the screwdriver [6].
 - Check that the cable is firmly seated.

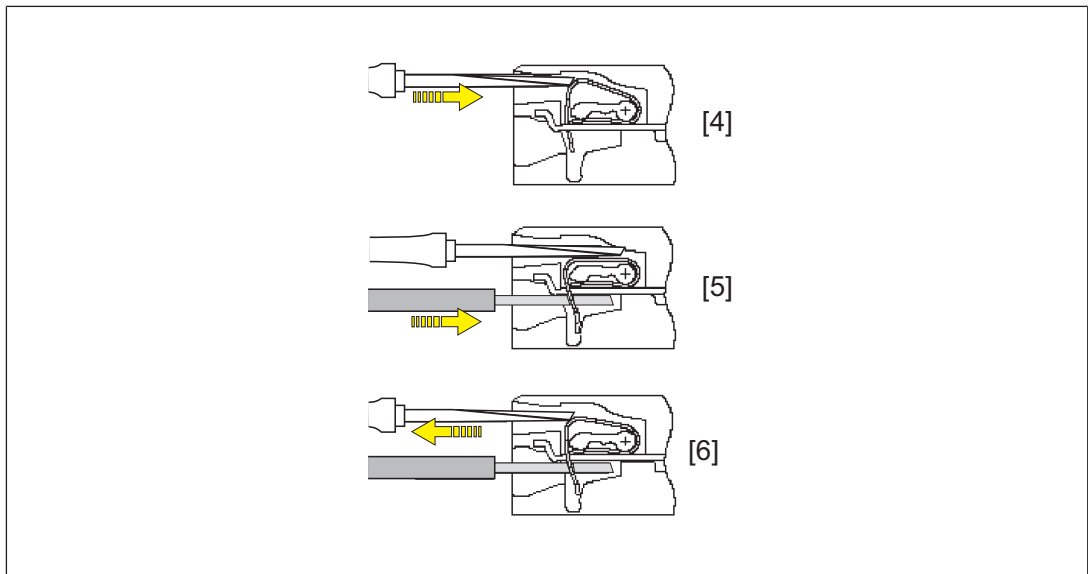
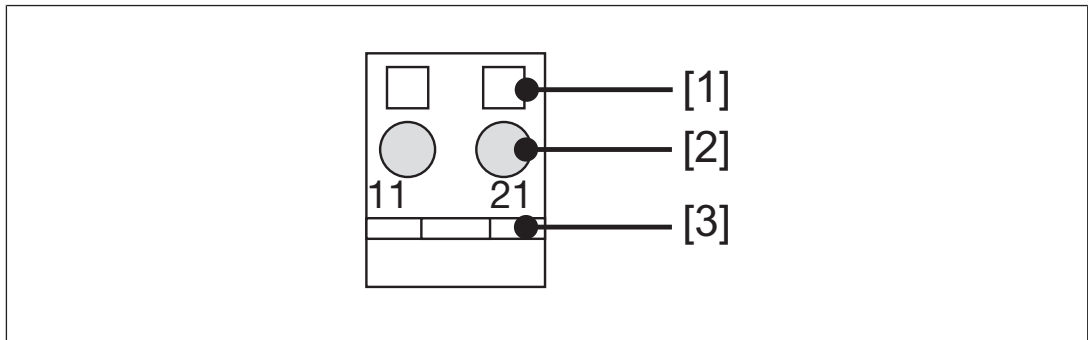

Please note:

- ▶ The minimum cable cross section for field connection terminals on the base modules is 0.14 mm² (AWG26).
- ▶ The maximum cable cross section for field connection terminals is:
 - Digital inputs: 1.5 mm² (AWG16)
 - Digital outputs: 2.0 mm² (AWG14)
 - Inputs/outputs on the counter modules: 1.5 mm² (AWG16)
 - Analogue inputs/outputs: 1.5 mm² (AWG16)
 - Communication cables: 1.5 mm² (AWG16)
 - Test pulse outputs: 1.5 mm² (AWG16)
 - Power supply: 2.5 mm² (AWG12)
 - Functional earth: 2.5 mm² (AWG12)

- ▶ On base modules with screw terminals:
 - If you use a multi-strand cable to connect the I/Os, it is recommended that you use ferrules conforming to Parts 1 and 2 of DIN 46228, 0.14 ... 1.5 mm², Form A or C, although this is not essential. To crimp the ferrules you can use crimp pliers (crimp form A or C) conforming to EN 60947-1, such as the PZ 1.5 or PZ 6.5 from Weidmüller, for example.
 - Maximum torque setting: 0.8 Nm
- ▶ Use copper wiring.

6.2 Terminal configuration

Base module	Terminal configuration	
Screw terminals: PSSu BP 1/8 S PSSu BP 1/8 S-T Cage clamp terminals: PSSu BP 1/8 C PSSu BP 1/8 C-T	Without C-rail: 11: Output O0 21: Output O1 12-22: 0 V periphery supply (12-22 linked within the base module) 13-23: 0 V periphery supply (13-23 linked within the base module) 14: Output O2 24: Output O3	

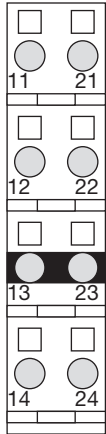
Base module	Terminal configuration	
<p>Screw terminals: PSSu BP-C 1/8 S PSSu BP-C 1/8 S-T</p> <p>Cage clamp terminals: PSSu BP-C 1/8 C PSSu BP-C 1/8 C-T</p>	<p>With C-rail:</p> <p>11: Output O0</p> <p>21: Output O1</p> <p>12-22: 0 V periphery supply (12-22 linked within the base module)</p> <p>13-23: C-rail supply (13-23 linked within the base module)</p> <p>14: Output O2</p> <p>24: Output O3</p>	

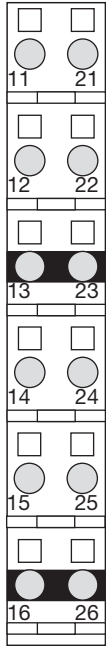
Base module	Terminal configuration	
<p>Screw terminals: PSSu BP-C1 1/12 S PSSu BP-C1 1/12 S-T</p> <p>Cage clamp terminals: PSSu BP-C1 1/12 C PSSu BP-C1 1/12 C-T</p>	<p>With C-rail:</p> <p>11: Output O0</p> <p>21: Output O1</p> <p>12-22: 0 V periphery supply (12-22 linked within the base module)</p> <p>13-23: C-rail supply (13-23-16-26 linked within the base module)</p> <p>14: Output O2</p> <p>24: Output O3</p> <p>15-25: 0 V periphery supply (15-25 linked within the base module)</p> <p>16-26: C-rail supply (13-23-16-26 linked within the base module)</p>	

6.3 Connecting the module

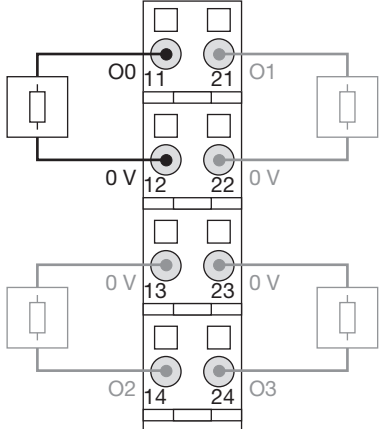
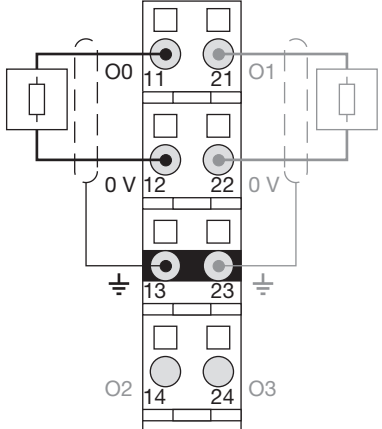
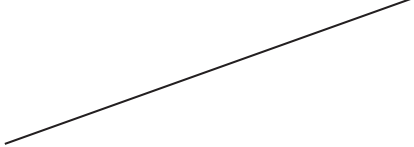
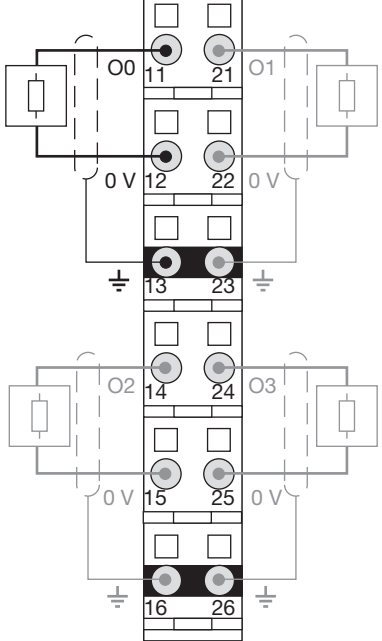
Output circuit	Without C-rail	With C-rail
<p>Single-channel actuator Base modules with four connection levels</p>		
<p>Single-channel actuator Base modules with six connection levels</p>		

7 Operation

7.1 Messages

An error will be signalled to the head module and will be entered in the head module's error stack. A module error will also be displayed via the "Err" LED (see section entitled "Display elements").

The module can detect the following errors:

Error	Explanation	Remedy
Start-up error	Error as the PSSu system starts up	Change faulty module.
Configuration error	Incorrect module type configured.	The configured hardware registry does not match the actual hardware registry.
ST communication error	Error during ST communication	Change faulty module.
Bus termination error	There is no terminating plate or there is a bad contact with the module bus.	Install a terminating plate with integrated end bracket or insert the base modules together correctly.
Overload/short circuit	Load on output too high.	Rectify overload or short circuit.
Temperature error: too warm ⁽¹⁾	Ambient temperature too high: Error stack entry	Ensure there is sufficient ventilation in the control cabinet or prevent overload.
Temperature error: too hot ⁽¹⁾	Ambient temperature too high: Outputs are switched off	Ensure there is sufficient ventilation in the control cabinet or prevent overload.

⁽¹⁾ There are two levels of overtemperature.

▶ Too warm:

If a module's temperature exceeds a threshold value, the module sends a warning to the head module. If the temperature drops back below the threshold value, the module sends an all-clear.

▶ Too hot:

If a module's temperature exceeds a further threshold value, the module sends an error message to the head module and switches off the outputs.

▶ After the "too hot" message has been received, if the temperature drops back below the "too warm" threshold value, the outputs will switch on if the head module has set the status of the outputs to "1".

Further information on PSSu error messages is available in the online help for the PSSuniversal Assistant system software.



7.2 Display elements

Legend

-  LED on
-  LED off



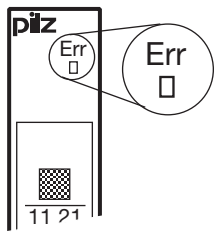



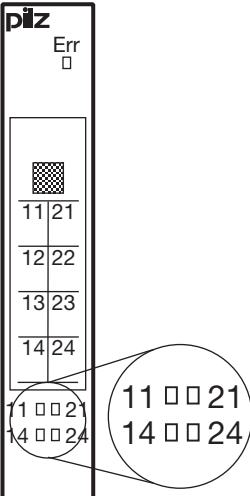

7.2.1 Display elements for module diagnostics

The "Err" LED is used to indicate a module error and a missing periphery supply.

	LED			Meaning
	Name	Colour	State	
	Err	---		No fault
	Red		Periphery supply is missing or module is faulty	

7.2.2 Display elements for output status

Each output is assigned an LED for displaying the output status (LEDs "11", "21", "14" and "24").

	LED			Meaning		
	Designation	Colour	Status	Signal	Output	Terminal
	11	---		0 signal	O0 (Output 0)	11
		Green		1 signal		
	21	---		0 signal	O1 (Output 1)	21
		Green		1 signal		
	14	---		0 signal	O2 (Output 2)	14
		Green		1 signal		
	24	---		0 signal	O3 (Output 3)	24
		Green		1 signal		

8 Technical details

General	312406	314406
Certifications	CE, UKCA, cULus Listed	CE, UKCA, cULus Listed
Application range	Standard	Standard
Module's device code	0411h	0411h
Number of ST output bits	4	4
Number of ST status bits	8	8
Application in system environment A		
from ST firmware version, other head modules	16	16
from ST firmware version PSSu H S PN	1	1
Application in system environment B		
from ST firmware version, head modules	1.8.0	1.8.0
Electrical data	312406	314406
Internal supply voltage (module supply)		
Module's power consumption	0,25 W	0,25 W
Periphery's supply voltage (peri- phery supply)		
Voltage range	16,8 - 30 V	16,8 - 30 V
Module's current consumption with no load	30 mA	30 mA
Module's power consumption with no load	0,72 W	0,72 W
Max. power dissipation of module	1,5 W	1,5 W
Semiconductor outputs	312406	314406
Number of positive-switching single-pole semiconductor outputs	4	4
Rated voltage	24 V DC	24 V DC
Typ. output current at "1" signal and rated voltage of semiconductor output	0,5 A	0,5 A
Max. output current with 1 output under load	2 A	2 A
Max. output current with 2 outputs under load	1,5 A	1,5 A
Permitted current range	0,000 - 0,620 A	0,000 - 0,620 A
Residual current at "0" signal	0,02 mA	0,02 mA
Max. transient pulsed current	6 A	6 A
Typ. threshold value for overload	8 A	8 A
Max. internal voltage drop	60 mV	60 mV

Semiconductor outputs		
	312406	314406
Max. processing time of semiconductor output when signal changes from "1" to "0"	0,5 ms	0,5 ms
Max. processing time of semiconductor output when signal changes from "0" to "1"	0,01 ms	0,01 ms
Potential isolation from system voltage	Yes	Yes
Short circuit-proof	Yes	Yes
Permitted loads	inductive, capacitive, resistive	inductive, capacitive, resistive
Environmental data		
	312406	314406
Climatic suitability	EN 60068-2-1, EN 60068-2-14, EN 60068-2-2, EN 60068-2-30, EN 60068-2-78	EN 60068-2-1, EN 60068-2-14, EN 60068-2-2, EN 60068-2-30, EN 60068-2-78
Ambient temperature		
in accordance with the standard	EN 60068-2-14	EN 60068-2-14
Temperature range	0 - 60 °C	-40 - 70 °C
Storage temperature		
in accordance with the standard	EN 60068-2-1/-2	EN 60068-2-1/-2
Temperature range	-25 - 70 °C	-40 - 70 °C
Climatic suitability		
in accordance with the standard	EN 60068-2-30, EN 60068-2-78	EN 60068-2-30, EN 60068-2-78
Humidity	93 % r. h. at 40 °C	93 % r. h. at 40 °C
Condensation during operation	Not permitted	Short-term
Max. operating height above SL	2000 m	5000 m
EMC	EN 61000-4-2, EN 61000-4-3, EN 61000-4-4, EN 61000-4-5, EN 61000-4-6, EN 61131-2	EN 61000-4-2, EN 61000-4-3, EN 61000-4-4, EN 61000-4-5, EN 61000-4-6, EN 61131-2
Vibration		
in accordance with the standard	EN 60068-2-6	EN 60068-2-6
Frequency	10 - 150 Hz	10 - 1000 Hz
Acceleration	1g	5g
Shock stress		
in accordance with the standard	EN 60068-2-27	EN 60068-2-27
Number of shocks	6	6
Acceleration	15g	15g
Duration	11 ms	11 ms
in accordance with the standard	EN 60068-2-27	EN 60068-2-27
Number of shocks	1000	1000
Acceleration	10g	25g
Duration	16 ms	6 ms
Airgap creepage		
in accordance with the standard	EN 60664-1, EN 61131-2	EN 60664-1, EN 61131-2
Overvoltage category	II	II
Pollution degree	2	2

Environmental data	312406	314406
Protection type		
in accordance with the standard	EN 60529	EN 60529
Housing	IP20	IP20
Mounting area (e.g. control cabinet)	IP54	IP54
Mechanical data	312406	314406
Material		
Bottom	PC	PC
Front	PC	PC
Coding	PA	PA
Dimensions		
Height	76 mm	76 mm
Width	12,6 mm	12,6 mm
Depth	60,2 mm	60,2 mm
Weight	33 g	34 g
Mechanical coding		
Type	B	B
Colour	Dark grey	Dark grey

Where standards are undated, the 2008-04 latest editions shall apply.

9 Supplementary data

9.1 Permitted operating height

The values stated in the technical details apply to the use of the device in operating heights up to max. 2000 m above SL. When used at higher levels, restrictions of the ambient temperature (standard IEC 61131-2) must be taken into account.

Operating height above SL [m]	Multiplication factors for the devices' ambient temperature
0 ... 2000	1.0
3000	0.9
4000	0.8
5000	0.7

10 Order reference

10.1 Product

Product type	Features	Order no.
PSSu E S 4DO 0.5-D	Electronic module, base type	312406
PSSu E S 4DO 0.5-TD	Electronic module, T-type	314406

10.2 Accessories

Base modules

Product type	Features	Order no.
PSSu BP 1/8 S	Base module without C-rail with screw terminals	312600
PSSu BP 1/8 S-T	Base module without C-rail with screw terminals, T-type	314600
PSSu BP 1/8 C	Base module without C-rail with cage clamp terminals	312601
PSSu BP 1/8 C-T	Base module without C-rail with cage clamp terminals, T-type	314601
PSSu BP-C 1/8 S	Base module with C-rail and screw terminals	312610
PSSu BP-C 1/8 S-T	Base module with C-rail and screw terminals, T-type	314610
PSSu BP-C 1/8 C	Base module with C-rail and cage clamp terminals	312611
PSSu BP-C 1/8 C-T	Base module with C-rail and cage clamp terminals, T-type	314611
PSSu BP 1/12 S	Base module without C-rail with screw terminals	312618
PSSu BP 1/12 S-T	Base module without C-rail with screw terminals, T-type	314618
PSSu BP 1/12 C	Base module without C-rail with cage clamp terminals	312619
PSSu BP 1/12 C-T	Base module without C-rail with cage clamp terminals, T-type	314619
PSSu BP-C1 1/12 S	Base module with C-rail and screw terminals	312622
PSSu BP-C1 1/12 S-T	Base module with C-rail and screw terminals, T-type	314622
PSSu BP-C1 1/12 C	Base module with C-rail and cage clamp terminals	312623
PSSu BP-C1 1/12 C-T	Base module with C-rail and cage clamp terminals, T-type	314623

