



► PSSu K S 16DI

PILZ

THE SPIRIT OF SAFETY

Operating Manual-22053-EN-10

- Decentralised system PSSuniversal I/O



This document is the original document.

Where unavoidable, for reasons of readability, the masculine form has been selected when formulating this document. We do assure you that all persons are regarded without discrimination and on an equal basis.

All rights to this documentation are reserved by Pilz GmbH & Co. KG. Copies may be made for the user's internal purposes. Suggestions and comments for improving this documentation will be gratefully received.

Pilz®, PIT®, PMI®, PNOZ®, Primo®, PSEN®, PSS®, PVIS®, SafetyBUS p®, SafetyEYE®, SafetyNET p®, the spirit of safety® are registered and protected trademarks of Pilz GmbH & Co. KG in some countries.



SD means Secure Digital

1	Introduction	5
1.1	Validity of documentation	5
1.1.1	Retaining the documentation	5
1.1.2	Terminology: System environment A and B	5
1.2	Definition of symbols	6
2	Overview	7
2.1	Module structure	7
2.2	Module features	7
2.3	Front view	8
3	Safety	9
3.1	Intended use	9
3.2	Safety regulations	10
3.2.1	Use of qualified personnel	10
3.2.2	Warranty and liability	10
3.2.3	Disposal	10
4	Function description	11
4.1	Block diagram	11
4.2	Module features	11
4.2.1	Function description	11
4.2.2	Integrated protection mechanisms	11
4.2.3	Reaction times	12
4.3	Configuration	12
4.3.1	PSSu assignment in system environment A	12
4.3.1.1	Addresses in the process image	12
4.3.2	PSSu assignment in system environment B	12
5	Installation	13
5.1	General installation guidelines	13
5.1.1	Dimensions	13
5.2	Install compact module	15
5.3	Install/uninstall connector	17
5.4	Install labelling bracket	19
6	Wiring	20
6.1	General wiring guidelines	20
6.1.1	Connectors' mechanical connection	20
6.1.2	Connect/disconnect the cables	20
6.2	Terminal configuration	22
6.3	Connecting the module	24
7	Operation	25
7.1	Messages	25
7.2	Display elements	26
7.2.1	Display elements for module diagnostics	26
7.2.2	Display elements for input status	26

8	Technical details	27
9	Order reference	30
9.1	Product.....	30
9.2	Accessories.....	30

1 Introduction

1.1 Validity of documentation

This documentation is valid for the product PSSu K S 16DI. It is valid until new documentation is published.

This operating manual explains the function and operation, describes the installation and provides guidelines on how to connect the product.

1.1.1 Retaining the documentation

This documentation is intended for instruction and should be retained for future reference.

1.1.2 Terminology: System environment A and B

The PSSu system can be used in two different system environments. The module's application area is described in the chapter "Intended Use" of the manual.

The distinction is made between

- ▶ PSSu in system environment A
- ▶ PSSu in system environment B

The distinction is based on the application area of the PSSu system.

PSSu in system environment A may be used in the

- ▶ Decentralised system PSSu I/O
- ▶ **Not** in the automation system PSS 4000

PSSu in system environment B may be used in the

- ▶ Automation system PSS 4000, e.g. with
 - Decentralised system PSSu I/O with SafetyNET p
 - Control system PSSu PLC
 - Control system PSSu multi

1.2 Definition of symbols

Information that is particularly important is identified as follows:



DANGER!

This warning must be heeded! It warns of a hazardous situation that poses an immediate threat of serious injury and death and indicates preventive measures that can be taken.



WARNING!

This warning must be heeded! It warns of a hazardous situation that could lead to serious injury and death and indicates preventive measures that can be taken.



CAUTION!

This refers to a hazard that can lead to a less serious or minor injury plus material damage, and also provides information on preventive measures that can be taken.



NOTICE

This describes a situation in which the product or devices could be damaged and also provides information on preventive measures that can be taken. It also highlights areas within the text that are of particular importance.



INFORMATION

This gives advice on applications and provides information on special features.

2 Overview

2.1 Module structure

The module combines the function unit (inputs or outputs) and connection levels in one housing.

Wiring is via 10-pin or 30-pin connectors with spring-loaded terminals, which are plugged into the connector strips on the module.

Details of the applicable connectors with spring-loaded terminals are available in the chapter entitled "Intended Use".

2.2 Module features

The product has the following features:

- ▶ 16 Digital inputs
- ▶ LEDs for:
 - Switch status of each input
 - Module error
- ▶ 2 x 10-pin connector strip
- ▶ Communication via:
 - Standard fieldbus
- ▶ For standard applications in system environment A and B

Accessories:

- ▶ Connector with spring-loaded terminals (necessary for operation)
- ▶ Labelling bracket
- ▶ Labelling strips (sheets)

2.3 Front view

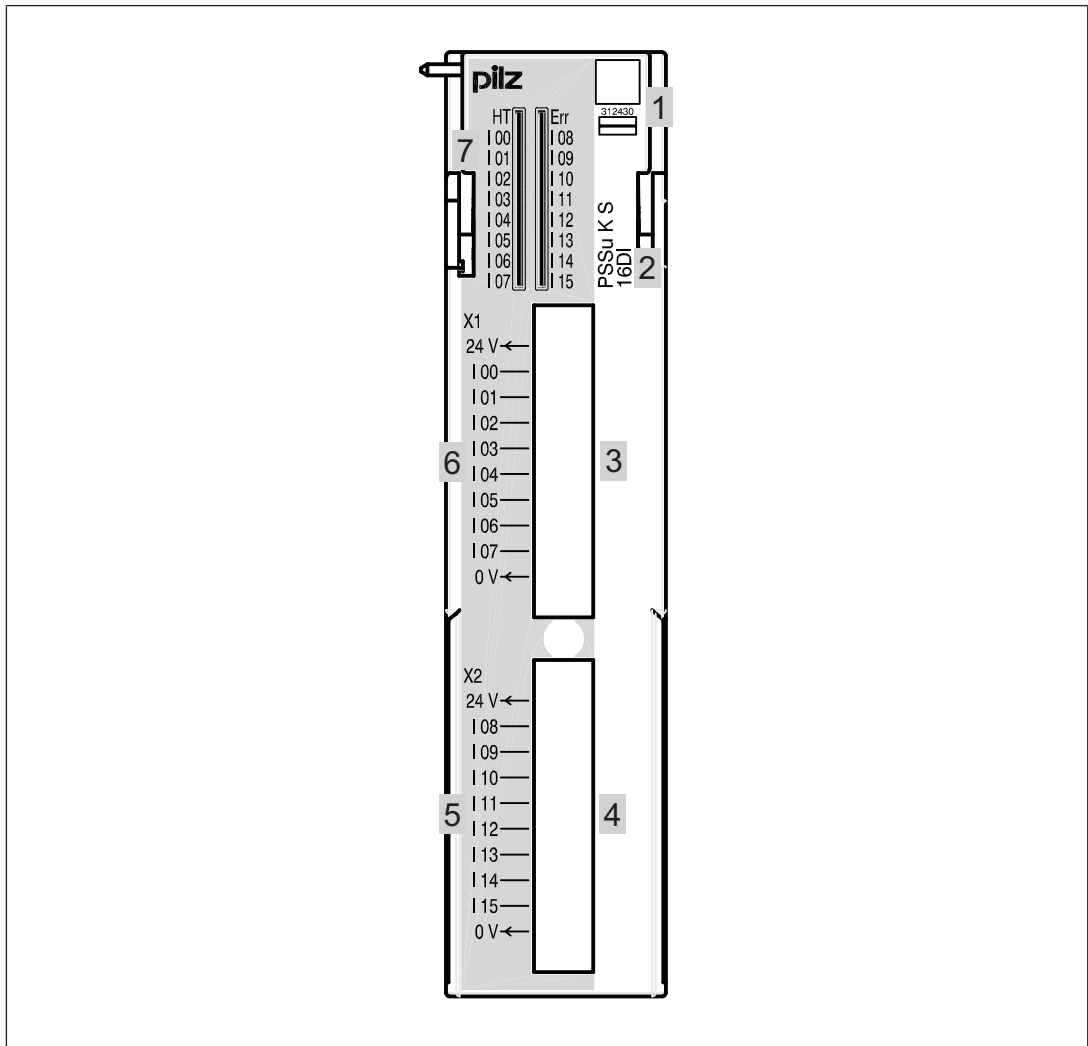

Key:

- ▶ 1: Labelling strip with:
 - 2D code
 - Order Number
 - Serial Number
 - Hardware version number
- ▶ 2: Name of compact module
- ▶ 3: Connector strip X1 for connectors with spring-loaded terminals
- ▶ 4: Connector strip X2 for connectors with spring-loaded terminals
- ▶ 5: Labelling strip for connector strip X2
- ▶ 6: Labelling strip for connector strip X1
- ▶ 7: LEDs for status display and module diagnostics

3 Safety

3.1 Intended use

The module may be used for standard applications in system environment A and B.

The module PSSu K S 16DI can be used as a non-safety-related component in accordance with the Lifts Directive 2014/33/EU. It meets the environmental requirements for passenger and goods lifts in accordance with EN 81-1/2, EN 81-20, EN 81-22 and EN 81-50, as well as the requirements for escalators and moving walks in accordance with EN 115-1.

The programmable safety system should be installed in a protected environment that meets at least the requirements of pollution degree 2. Example: Protected inside space or control cabinet with protection class IP54 and corresponding air conditioning.

The module provides type 1 inputs in accordance with IEC 61131-2. It may be used as an input module for standard functions.

Intended use includes making the electrical installation EMC-compliant. Please refer to the guidelines stated in the "PSSuniversal Installation Manual". The module is designed for use in an industrial environment. It is not suitable for use in a domestic environment, as this can lead to interference.

The following is deemed improper use in particular:

- ▶ Any component, technical or electrical modification to the module
- ▶ Use of the module outside the areas described in this manual
- ▶ Any use of the module that is not in accordance with the technical details.



INFORMATION

The module is supported by:

- ▶ PSSuniversal Configurator and PSSuniversal Assistant from Version 1.8.1.
- ▶ PAS4000 from Version 1.7.0
 - We recommend that you always use the latest version (download from www.pilz.com).

The PSSu K S 16DI module may be used with the following connectors with spring-loaded terminals:

- ▶ PSSu A Con 1/10 C
- ▶ PSSu A Con 3/30 C



WARNING!

The module may **not** be used in combination with PSSu E F BSW(-T) modules in safety-related applications.

3.2 Safety regulations

3.2.1 Use of qualified personnel

The products may only be assembled, installed, programmed, commissioned, operated, maintained and decommissioned by persons who are competent to do so.

A competent person is a qualified and knowledgeable person who, because of their training, experience and current professional activity, has the specialist knowledge required. To be able to inspect, assess and operate devices, systems and machines, the person has to be informed of the state of the art and the applicable national, European and international laws, directives and standards.

It is the company's responsibility only to employ personnel who

- ▶ Are familiar with the basic regulations concerning health and safety / accident prevention,
- ▶ Have read and understood the information provided in the section entitled Safety
- ▶ Have a good knowledge of the generic and specialist standards applicable to the specific application.

3.2.2 Warranty and liability

All claims to warranty and liability will be rendered invalid if

- ▶ The product was used contrary to the purpose for which it is intended,
- ▶ Damage can be attributed to not having followed the guidelines in the manual,
- ▶ Operating personnel are not suitably qualified,
- ▶ Any type of modification has been made (e.g. exchanging components on the PCB boards, soldering work etc.).

3.2.3 Disposal

- ▶ In safety-related applications, please comply with the mission time T_M in the safety-related characteristic data.
- ▶ When decommissioning, please comply with local regulations regarding the disposal of electronic devices (e.g. Electrical and Electronic Equipment Act).

4 Function description

4.1 Block diagram

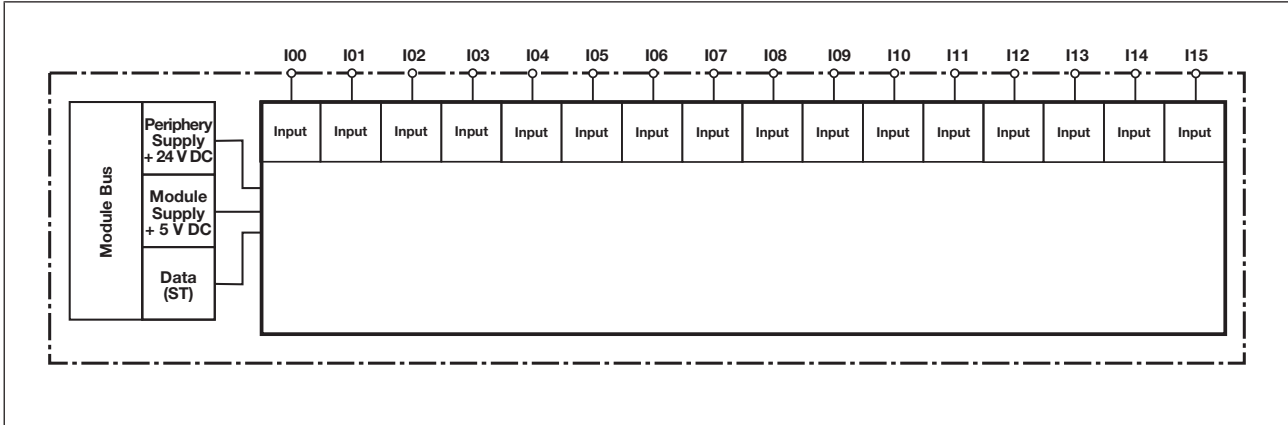

4.2 Module features

4.2.1 Function description

Module supply

- ▶ The module supply provides the module with voltage.

Periphery supply

- ▶ The module routes the periphery supply from the module bus to the module's connector strips.
- ▶ The periphery supply is used to supply the sensors.
- ▶ The module does not switch the periphery supply.
- ▶ The periphery supply has no current limitation.

Inputs

- ▶ The input status is signalled to the head module via the module bus.
- ▶ The inputs have input filters.

4.2.2 Integrated protection mechanisms

When the PSSu E F PS1(-T) or PSSu E F PS2(-T)(-R) is used to supply the system, the module supply is buffered for 20 ms if the supply voltage is interrupted.

The module provides the following diagnostic data:

- ▶ Start-up error
- ▶ Configuration error
- ▶ ST communication error
- ▶ Bus termination error
- ▶ Temperature error

4.2.3 Reaction times

Information on the reaction times of the inputs can be found in the "PSSuniversal" System Description and the System Description "Automation system PSS 4000".

4.3 Configuration

4.3.1 PSSu assignment in system environment A

It is not necessary to configure ST inputs in the PSSuniversal Configurator on the PSS WIN-PRO system software, but ST modules can be selected and displayed.

The ST process image can be optimised by combining adjacent bits of the same type into bytes.

Further information on configuration is available in the PSSuniversal Configurator's online help.

4.3.1.1 Addresses in the process image

The module occupies 16 consecutive bit addresses in the process image.

Configuration	SafetyBUS p	Standard bus system	
	FS-P11	ST-P11	ST-PIO
None	---	16 Bit	---

4.3.2 PSSu assignment in system environment B

Data access is via pre-defined I/O data types:

I/O data name	I/O data type	I/O data element	Meaning
I00 ... I07	ST_I_DI	Data: BOOL	Input data I00 ... I07
O00 ... O07	ST_O_DO	Data: BOOL	Output data O00 ... O07

5 Installation

5.1 General installation guidelines

Please refer also to the PSSuniversal Installation Manual.



NOTICE

Damage due to electrostatic discharge!

Electrostatic discharge can damage components. Ensure against discharge before touching the product, e.g. by touching an earthed, conductive surface or by wearing an earthed armband.

5.1.1 Dimensions

Module with connector:

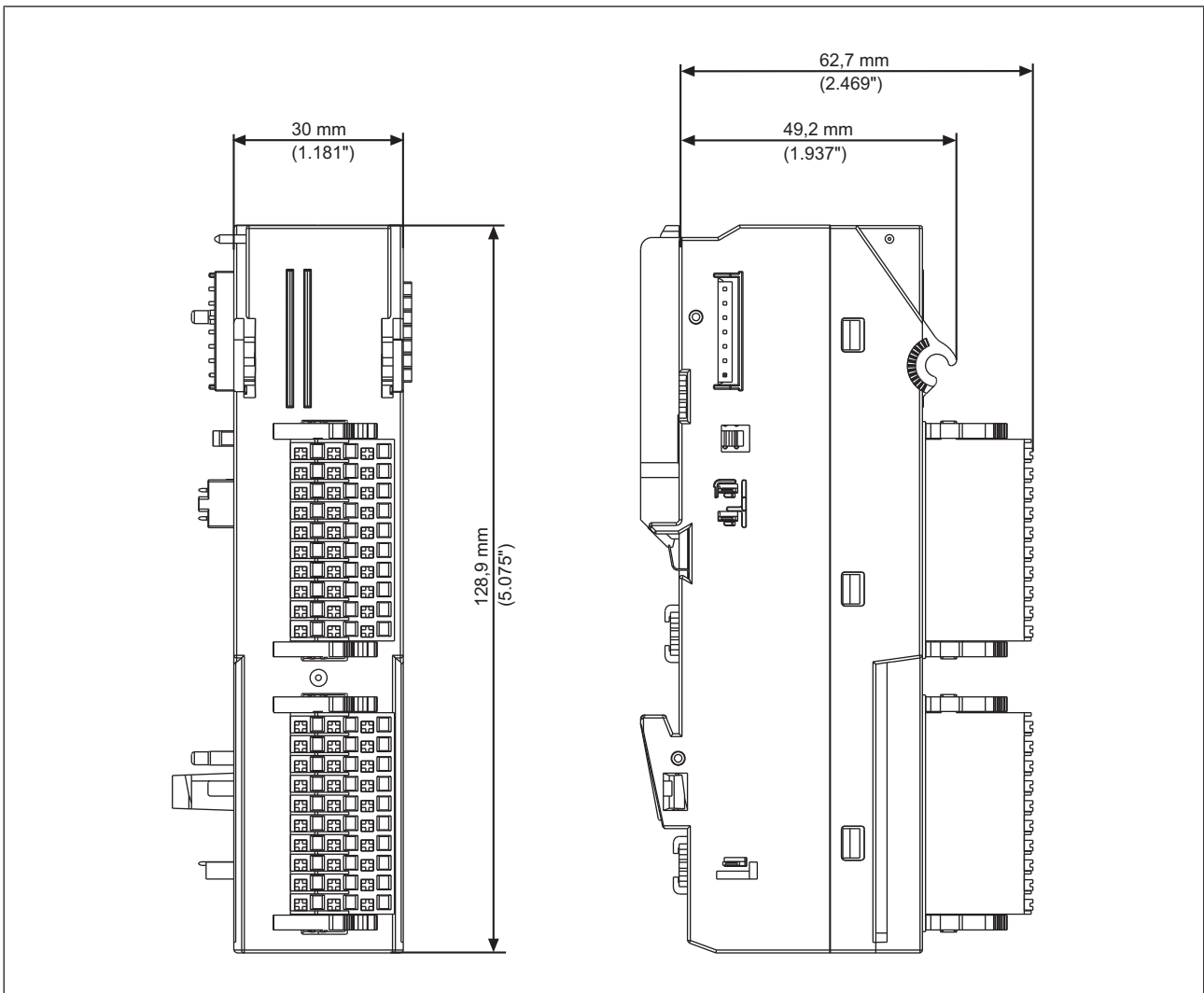

Module with connector and labelling bracket:

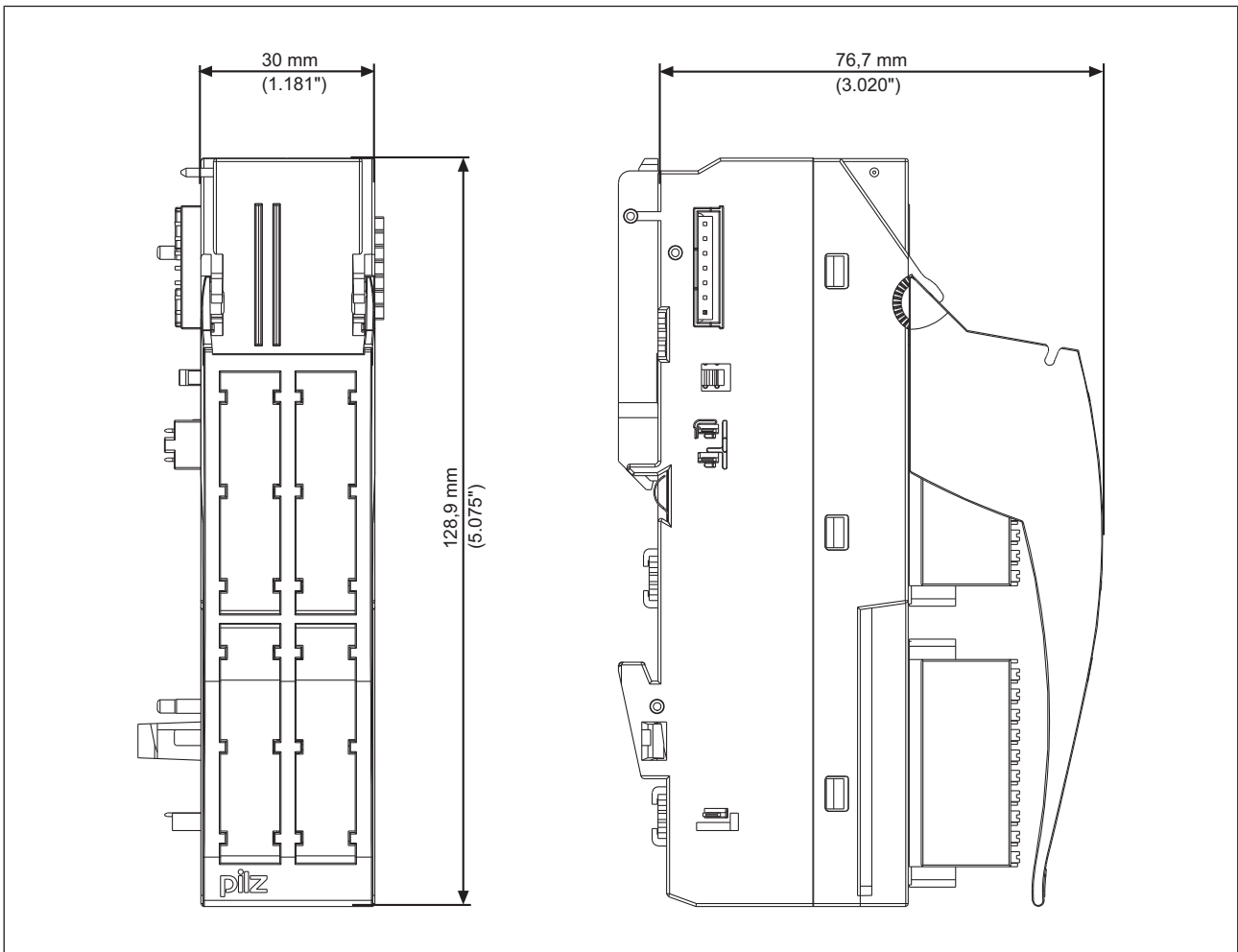

5.2 Install compact module

Prerequisite:

- ▶ The head module must be installed.
- ▶ If the head module does not have an integrated power supply, a supply voltage module must be installed to the right of the head module.
- ▶ A base module with screw terminals may not be installed to the left of the compact module.

Please note:

- ▶ All contacts should be protected from contamination.
- ▶ The mechanics of the compact modules are designed for 50 plug in/out cycles.

Procedure:

- ▶ Slot the groove on the compact module on to the mounting rail from below [1].
- ▶ Push the compact module back as far as it will go [2].
- ▶ Make sure that the locking mechanism [3] is pushed downwards, connecting the module firmly to the mounting rail.
- ▶ On the mounting rail, slide the compact module to the left.



NOTICE

Potential contact damage due to twisting!

The contacts for the Module Supply and Periphery Supply can be bent by twisting the compact modules on the mounting rail.

- On the mounting rail, carefully slide the compact module to the left, in parallel to the adjoining module, until you hear the lateral mounting hooks on the adjacent module lock into position [4].

Schematic representation:

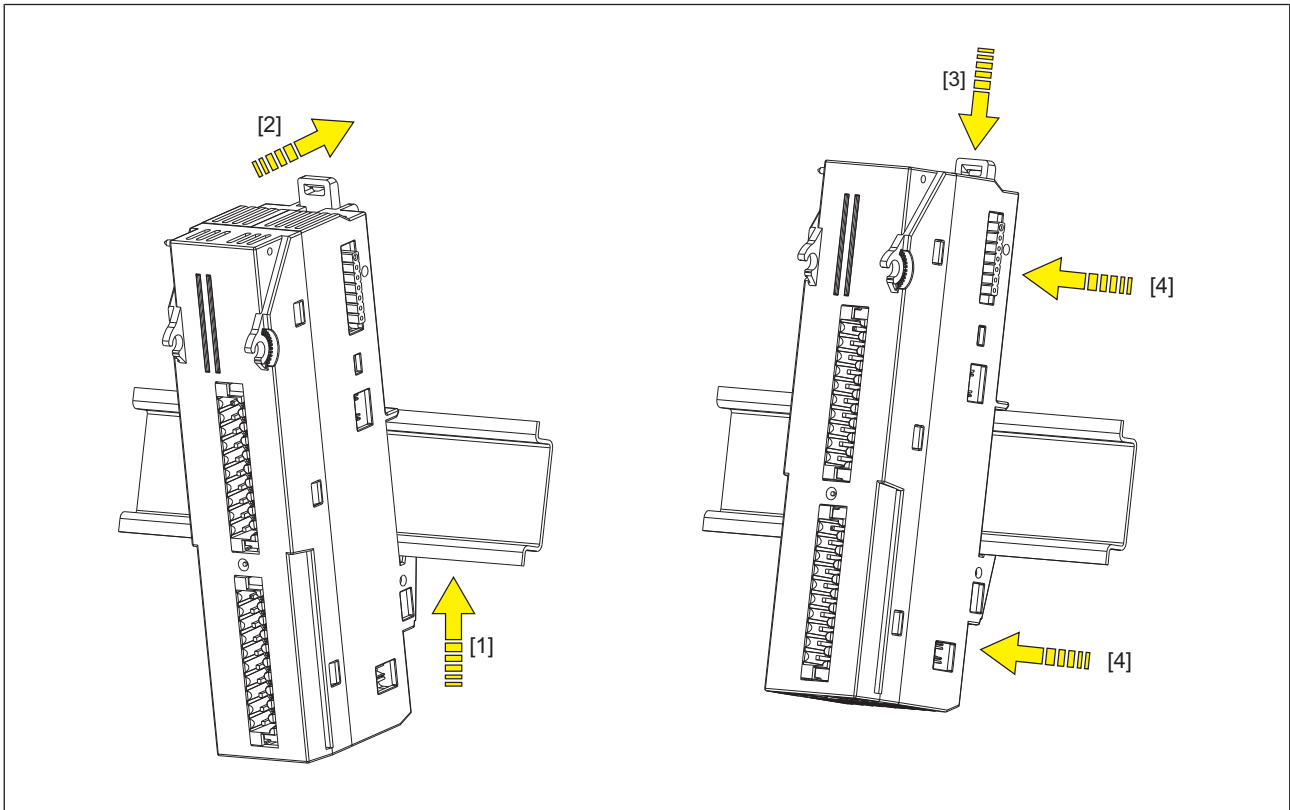

5.3 Install/uninstall connector

We recommend that the connectors with spring-loaded terminals are wired before they are plugged in.

Please note:

- ▶ All contacts should be protected from contamination.
- ▶ The mechanics of the connector are designed for 25 plug in/out cycles.

Installation procedure:

- ▶ Plug the connector into the required connector strip until you hear it lock into position [1].



INFORMATION

The two locking levers automatically hook into place when plugged in. As a result the connector is firmly connected to the module.

Schematic representation:

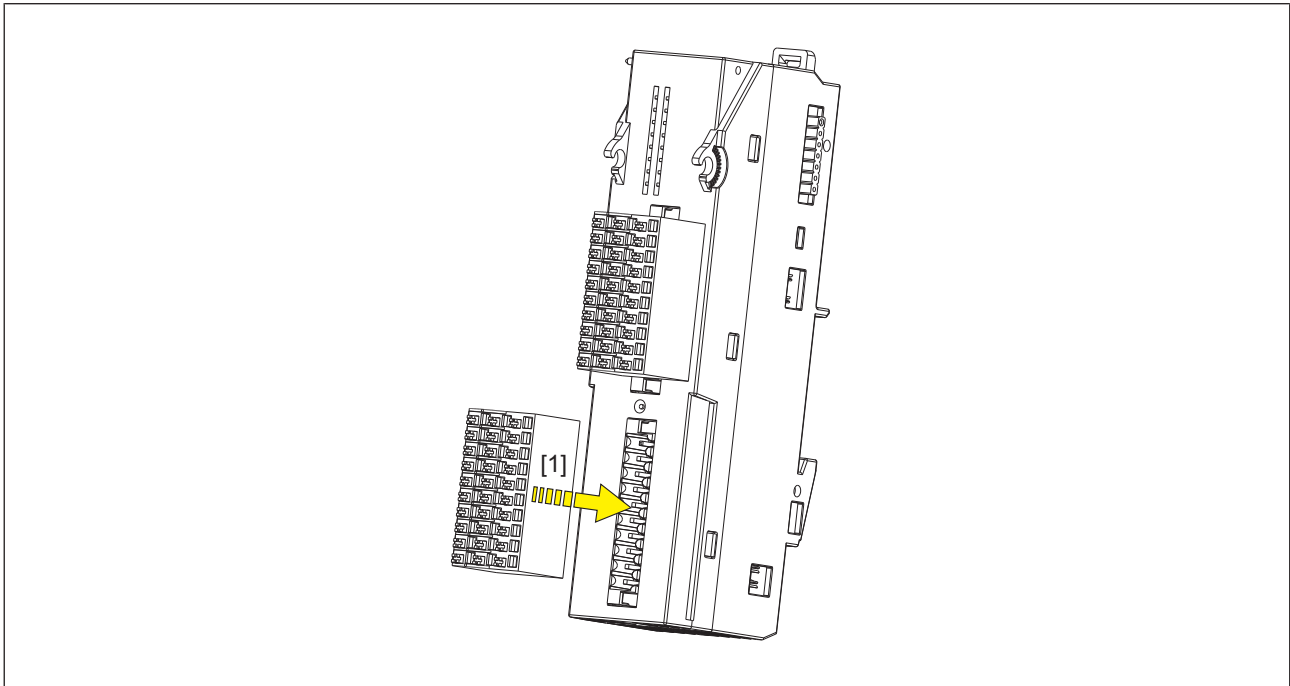

Uninstallation procedure:

- ▶ Push both locking levers to the left, as far as they will go [1].



INFORMATION

This will automatically lift the connector, which can then be removed from the module.



NOTICE

As you remove the connector, grasp the connector housing and not the cable harness.

Schematic representation:

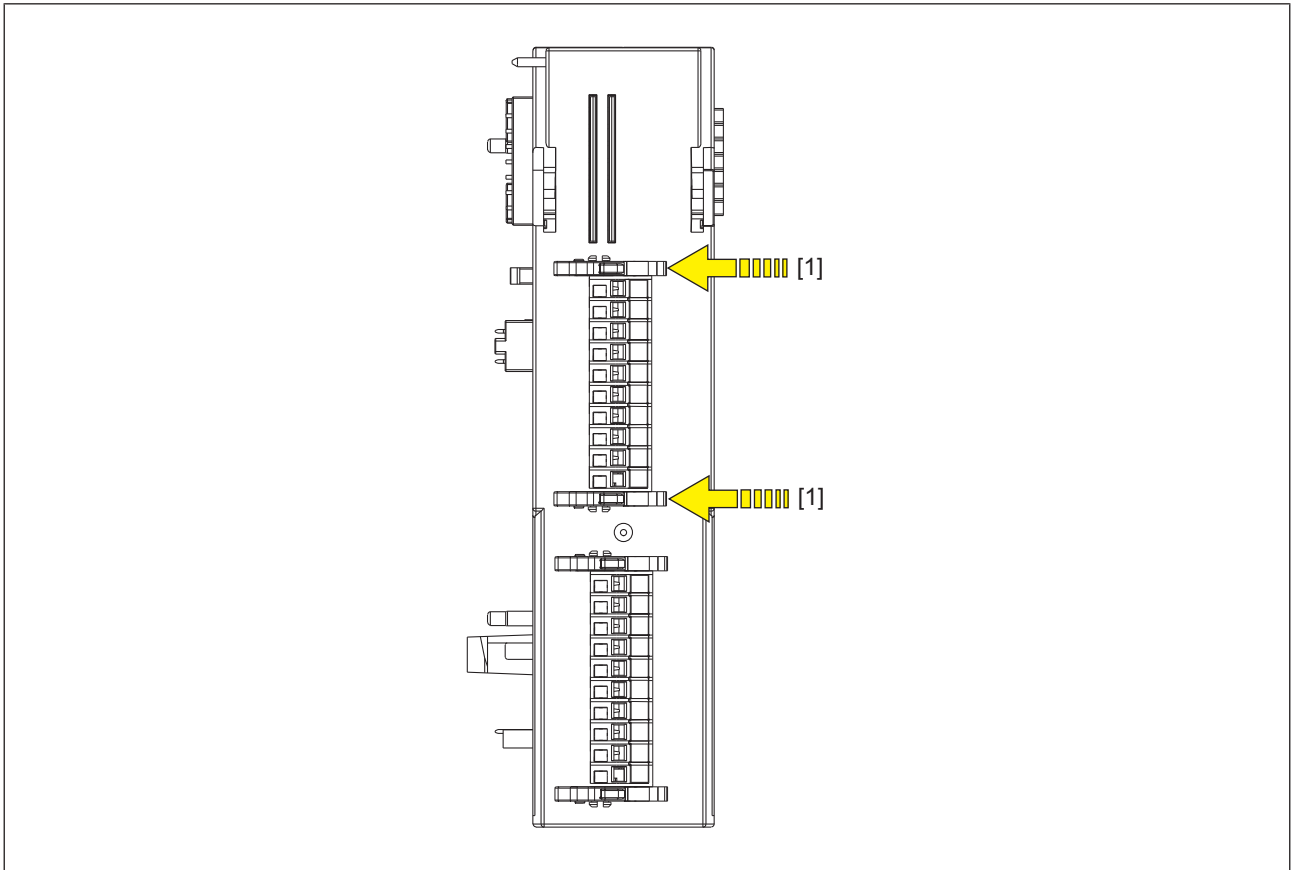

5.4 Install labelling bracket

Installation procedure:

- ▶ We recommend that the labelling strips are attached to the labelling bracket prior to installation.
- ▶ Slot the two pins on the labelling bracket into the receiving lugs on the module [1].
- ▶ Check that the labelling bracket is firmly seated.

Schematic representation:

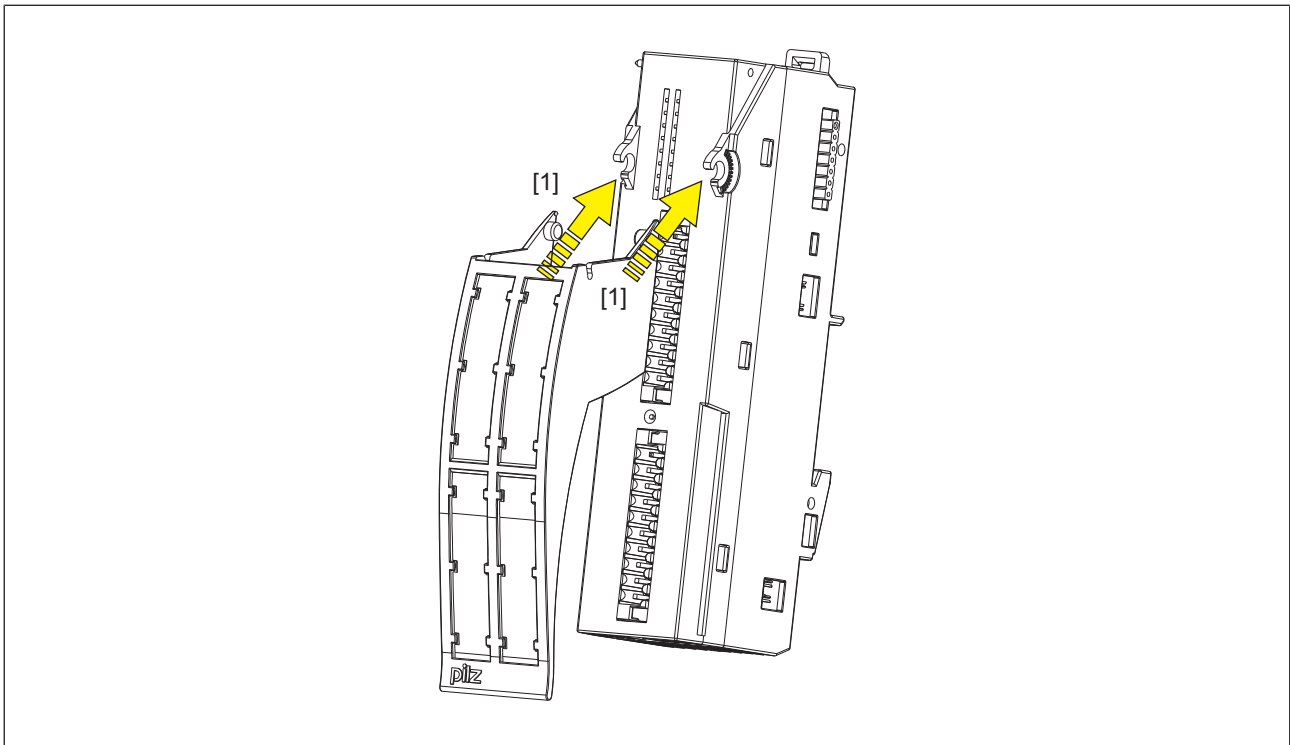

6 Wiring

6.1 General wiring guidelines

Please note:

- ▶ Signal lines do not have to be shielded.

6.1.1 Connectors' mechanical connection

Please note:

- ▶ The conductor cross section on the spring-loaded terminals without ferrules is 0,2 - 1 mm², 22 - 18 AWG.
- ▶ If you are using multi-core or fine-core cables we recommend ferrules in accordance with DIN 46228/Part 1 or DIN 46228/Part 4, 0.2 ... 1 mm². To crimp the ferrules we recommend crimping pliers (crimp form A) conforming to EN 60947-1, such as the PZ 6/5 from Weidmüller, for example.
- ▶ Terminal points per connection: 1
- ▶ Stripping length: 8 mm

6.1.2 Connect/disconnect the cables

We recommend you use a screw driver with a 0.4 x 2.5 mm (DIN 5264) blade!

Strip the cable:

- ▶ Strip the cable [1] and apply a ferrule if necessary (DIN 46228/Part 1 or DIN 46228/Part 4).

Connect cable:

- ▶ Using the screwdriver, press the actuator button on the spring-loaded terminal down as far as it will go [2], keep it held down and insert the stripped cable into the plug connection as far as it will go [2].
- ▶ Check that the cable is firmly seated [3].

Disconnect cable:

- ▶ Using the screwdriver, press the actuator button down as far as it will go [4], keep it held down and pull the cable out of the plug connection [4].

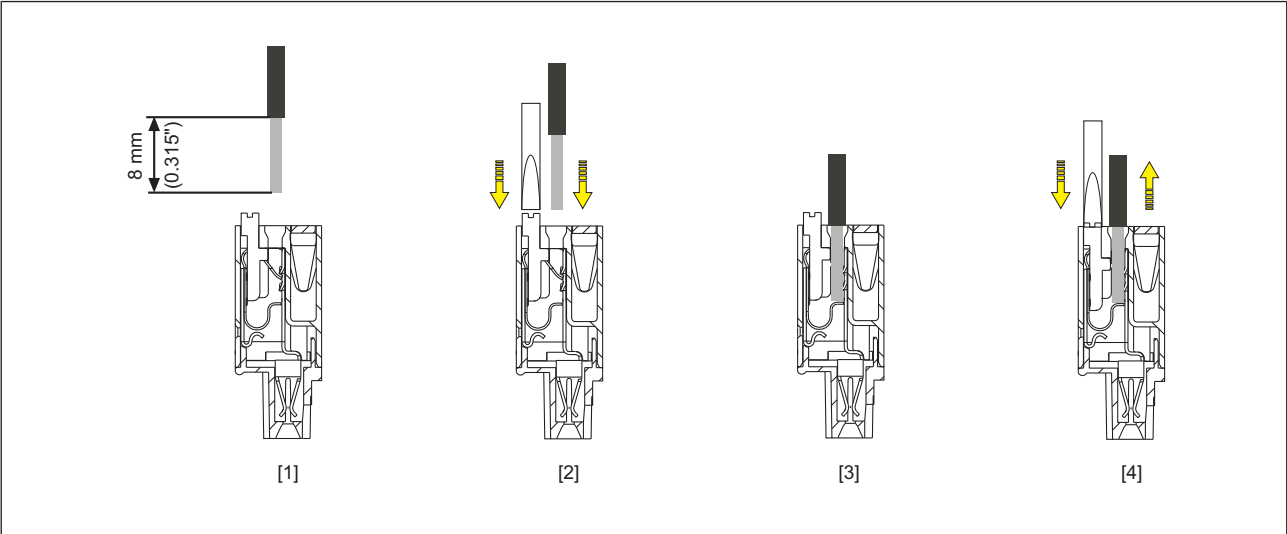
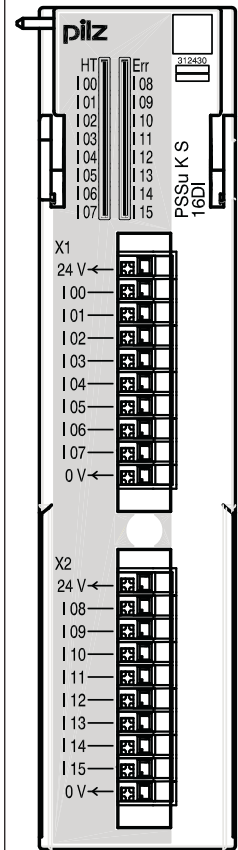

Fig.: Connect and disconnect the cables

6.2 Terminal configuration

Terminal configuration	
<p>Connector with spring-loaded terminals (1-row/10-pin): PSSu A Con 1/10 C</p>	<p>1. connection level</p> <p>X1:</p> <p>24 V: +24 V (periphery supply)</p> <p>I 00: Input 0</p> <p>I 01: Input 1</p> <p>I 02: Input 2</p> <p>I 03: Input 3</p> <p>I 04: Input 4</p> <p>I 05: Input 5</p> <p>I 06: Input 6</p> <p>I 07: Input 7</p> <p>0 V: 0 V (periphery supply)</p> <p>X2:</p> <p>24 V: +24 V (periphery supply)</p> <p>I 08: Input 8</p> <p>I 09: Input 9</p> <p>I 10: Input 10</p> <p>I 11: Input 11</p> <p>I 12: Input 12</p> <p>I 13: Input 13</p> <p>I 14: Input 14</p> <p>I 15: Input 15</p> <p>0 V: 0 V (periphery supply)</p>



Terminal configuration				
<p>Connector with spring-loaded terminals (3-row/30-pin): PSSu A Con 3/30 C</p>	<p>1. connection level</p> <p>X1: 24 V: +24 V (periphery supply) I 00: Input 0 I 01: Input 1 I 02: Input 2 I 03: Input 3 I 04: Input 4 I 05: Input 5 I 06: Input 6 I 07: Input 7 0 V: 0 V (periphery supply)</p> <p>X2: 24 V: +24 V (periphery supply) I 08: Input 8 I 09: Input 9 I 10: Input 10 I 11: Input 11 I 12: Input 12 I 13: Input 13 I 14: Input 14 I 15: Input 15 0 V: 0 V (periphery supply)</p>	<p>2. connection level</p> <p>X1: +24 V (periphery supply) is present at all 10 spring-loaded terminals.</p> <p>X2: +24 V (periphery supply) is present at all 10 spring-loaded terminals.</p>	<p>3. connection level</p> <p>X1: 0 V (periphery supply) is present at all 10 spring-loaded terminals.</p> <p>X2: 0 V (periphery supply) is present at all 10 spring-loaded terminals.</p>	<p>The diagram shows a 30-pin connector with two rows of terminals. The top row (X1) contains terminals I00 through I07, a 24V supply terminal, and a 0V supply terminal. The bottom row (X2) contains terminals I08 through I15, a 24V supply terminal, and a 0V supply terminal. A separate section at the top shows terminals HT, Err, and I08 through I15.</p>

6.3 Connecting the module

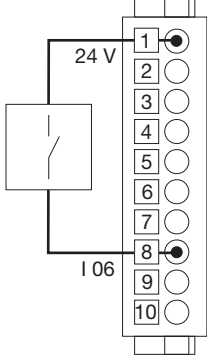
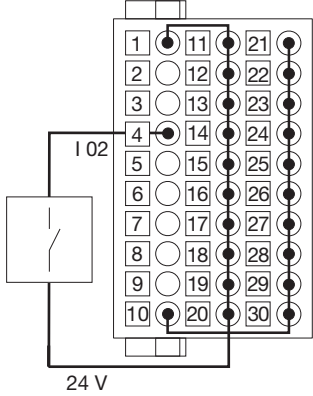
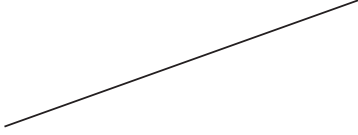
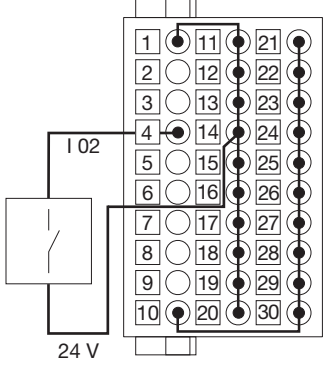
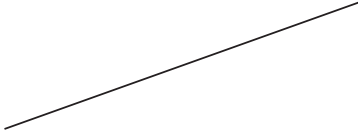
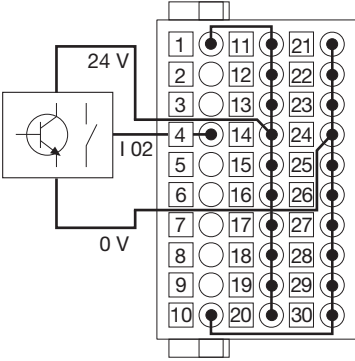
Input circuit	1-row/10-pin connector PSSu A Con 1/10 C	3-row/30-pin connector PSSu A Con 3/30 C
Single-wire technology		
Two-wire technology		
Three-wire technology		

7 Operation

7.1 Messages

A module error is displayed via the "Err" LED (see section entitled "Display elements"). It is signalled to the head module and then entered in the

- ▶ Error stack, with PSSu in system environment A
- ▶ Diagnostic log, with PSSu in system environment B.

of the head module.



The module can detect the following errors:

Error	Explanation	Remedy
Start-up error	Error as the PSSu system starts up.	Change faulty module.
Configuration error	Incorrect module type configured.	The configured hardware registry does not match the actual hardware registry.
ST communication error	Error in ST communication with the head module.	Change faulty module.
Bus termination error	There is no end bracket.	Install a terminating plate with integrated end angle.
Temperature error: too warm	Temperature in module too high: Error stack entry	Ensure there is sufficient ventilation in the control cabinet or prevent overload.

Further information on PSSu error messages is available in the online help for the PSSuniversal Assistant system software.



7.2 Display elements

Legend

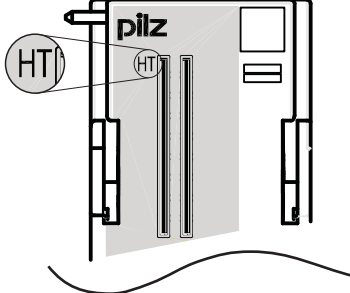

-  LED on
-  LED off

7.2.1 Display elements for module diagnostics

The module has an LED for displaying temperature errors ("HT" LED).

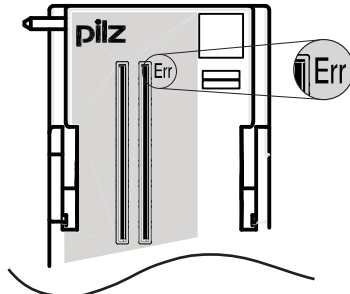

	LED			Meaning
	Designation	Colour	Status	
	HT	---	●	No error
	Yellow		Temperature too high	

The module has an LED for displaying module errors ("Err" LED).

	LED			Meaning
	Designation	Colour	Status	
	Err	---	●	No error
	Red		Module is faulty	

7.2.2 Display elements for input status

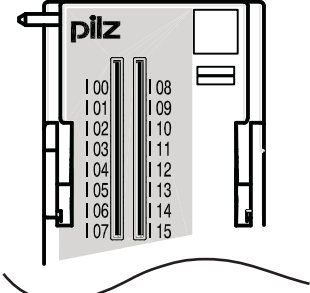
Each input is assigned an LED for displaying the input status (LEDs "I 00 ... I 15").

	LED			Meaning
	Designation	Colour	Status	Signal
	I 00	---	●	0 signal
	.	Green		1 signal
	.			
I 15				

8 Technical details

General	
Certifications	BG, CE, TÜV, UKCA, cULus Listed
Application range	Standard
Module's device code	0230h
Number of ST input bits	16
Application in system environment A	
from ST firmware version, other head modules	17
from ST firmware version PSSu H S PN	2
from ST firmware version PSSu WR S IDN	9
Application in system environment B	
from ST firmware version, head modules	1.7.0
Electrical data	
Internal supply voltage (module supply)	
Module's power consumption	0,24 W
Periphery's supply voltage (periphery supply)	
Voltage range	16,8 - 30 V
Module's current consumption with no load	0 mA
Module's power consumption with no load	0,00 W
Max. power dissipation of module	2 W
Inputs	
Quantity	16
Input voltage in accordance with EN 61131-2 Type 1	24 V DC
Input current at rated voltage	3 mA
Input current range	2,5 - 4 mA
Min. threshold voltage when signal changes from "1" to "0"	11 V
Max. threshold voltage when signal changes from "0" to "1"	12 V
Max. processing time of input when signal changes from "1" to "0"	4 ms
Max. processing time of input when signal changes from "0" to "1"	4 ms
Min. processing time of input when signal changes from "1" to "0"	3 ms
Min. processing time of input when signal changes from "0" to "1"	3 ms
Potential isolation between input and internal module bus voltage	Yes
Environmental data	
Climatic suitability	EN 60068-2-1, EN 60068-2-14, EN 60068-2-2, EN 60068-2-30, EN 60068-2-78
Ambient temperature	
in accordance with the standard	EN 60068-2-14
Temperature range	0 - 60 °C

Environmental data

Storage temperature	
in accordance with the standard	EN 60068-2-1/-2
Temperature range	-25 - 70 °C
Climatic suitability	
in accordance with the standard	EN 60068-2-30, EN 60068-2-78
Humidity	93 % r. h. at 40 °C
Condensation during operation	Not permitted
Max. operating height above SL	2000 m
EMC	EN 55011: class A, EN 61000-4-11, EN 61000-4-2, EN 61000-4-3, EN 61000-4-4, EN 61000-4-5, EN 61000-4-6, EN 61000-4-8, EN 61000-4-9
Vibration	
in accordance with the standard	EN 60068-2-6
Frequency	10 - 55 Hz
Amplitude	0,35 mm
Acceleration	1g
Shock stress	
in accordance with the standard	EN 60068-2-27
Number of shocks	6
Acceleration	15g
Duration	11 ms
in accordance with the standard	EN 60068-2-27
Number of shocks	1000
Acceleration	10g
Duration	16 ms
Airgap creepage	
in accordance with the standard	EN 60664-1, EN 61131-2
Overvoltage category	II
Pollution degree	2
Protection type	
in accordance with the standard	EN 60529
Housing	IP20
Mounting area (e.g. control cabinet)	IP54

Mechanical data

Material	
Bottom	PC
Front	PC
Labelling bracket (accessories)	PC
Mounting type	plug-in
Conductor cross section with spring-loaded terminals: Flexible with/without crimp connector	0,2 - 1 mm², 22 - 18 AWG
Spring-loaded terminals: Terminal points per connection	1
Stripping length with spring-loaded terminals	8 mm

Mechanical data

Dimensions

Height	128,9 mm
Width	30 mm
Depth	56 mm
Depth incl. connector (accessories)	69,5 mm
Depth incl. labelling bracket (accessories)	83,5 mm
Weight	87 g

Where standards are undated, the 2005-04 latest editions shall apply.

9 Order reference

9.1 Product

Product type	Features	Order no.
PSSu K S 16DI	Compact module without connector, labelling bracket and labelling strips, base type	312430

9.2 Accessories

Terminals

Product type	Features	Order no.
PSSu A Con 1/10 C	Connector with spring-loaded terminals 1-row/10-pin, scope of supply: 2 pieces	313115
PSSu A Con 3/30 C	Connector with spring-loaded terminals 3-row/30-pin, scope of supply: 2 pieces	313116

Labelling

Product type	Features	Order no.
PSSu A LC 0.1	Labelling bracket, scope of delivery: 5 pieces	312966
PSSu A LA0	Labelling strips, laser printable, scope of delivery: 1080 pieces (10 x DIN A4 sheet, 108 on each)	312958

► Support

Technical support is available from Pilz round the clock.

Americas

Brazil

+55 11 97569-2804

Canada

+1 888 315 7459

Mexico

+52 55 5572 1300

USA (toll-free)

+1 877-PILZUSA (745-9872)

Asia

China

+86 21 60880878-216

Japan

+81 45 471-2281

South Korea

+82 31 778 3300

Australia and Oceania

Australia

+61 3 95600621

New Zealand

+64 9 6345350

Europe

Austria

+43 1 7986263-0

Belgium, Luxembourg

+32 9 3217570

France

+33 3 88104003

Germany

+49 711 3409-444

Ireland

+353 21 4804983

Italy, Malta

+39 0362 1826711

Scandinavia

+45 74436332

Spain

+34 938497433

Switzerland

+41 62 88979-32

The Netherlands

+31 347 320477

Turkey

+90 216 5775552

United Kingdom

+44 1536 462203

You can reach our international hotline on:

+49 711 3409-222

support@pilz.com

Pilz develops environmentally-friendly products using ecological materials and energy-saving technologies. Offices and production facilities are ecologically designed, environmentally-aware and energy-saving. So Pilz offers sustainability, plus the security of using energy-efficient products and environmentally-friendly solutions.



We are represented internationally. Please refer to our homepage www.pilz.com for further details or contact our headquarters.

Headquarters: Pilz GmbH & Co. KG, Felix-Wankel-Straße 2, 73760 Ostfildern, Germany
Telephone: +49 711 3409-0, Telefax: +49 711 3409-133, E-Mail: info@pilz.com, Internet: www.pilz.com

PILZ
THE SPIRIT OF SAFETY

22053-EN-10, 2023-06 Printed in Germany
© Pilz GmbH & Co. KG, 2019

CECE®, CHRE®, CMSE®, InduraNET p®, Leansafe®, Master of Safety®, Master of Security®, PAS4000®, PAScall®, PASconfig®, Pilz®, PTT®, PLID®, PMCPirimo®, PMCPiritego®, PMCTendo®, PMD®, PMJ®, PNOZ®, PRBM®, PRCM®, PRIMO®, PRM®, PSEN®, PSENi®, PSS®, PVS®, SafetyBUS p®, SafetyEYE®, SafetyNET p®, THE SPIRIT OF SAFETY® are registered and protected trademarks of Pilz GmbH & Co. KG in some countries. We would point out that product features may vary from the details stated in this document, depending on the status at the time of publication and the scope of the equipment. We accept no responsibility for the validity, accuracy and entirety of the text and graphics presented in this information. Please contact our Technical Support if you have any questions.