



▶ PSSu E S 2AO I(-T)

PILZ

THE SPIRIT OF SAFETY

Operating Manual-21435-EN-05

- Decentralised system PSSuniversal I/O



This document is the original document.

Where unavoidable, for reasons of readability, the masculine form has been selected when formulating this document. We do assure you that all persons are regarded without discrimination and on an equal basis.

All rights to this documentation are reserved by Pilz GmbH & Co. KG. Copies may be made for the user's internal purposes. Suggestions and comments for improving this documentation will be gratefully received.

Pilz®, PIT®, PMI®, PNOZ®, Primo®, PSEN®, PSS®, PVIS®, SafetyBUS p®, SafetyEYE®, SafetyNET p®, the spirit of safety® are registered and protected trademarks of Pilz GmbH & Co. KG in some countries.



SD means Secure Digital

1	Introduction	5
1.1	Validity of documentation	5
1.1.1	Retaining the documentation	5
1.1.2	Terminology: System environment A and B	5
1.2	Definition of symbols	6
2	Overview	7
2.1	Module structure	7
2.2	Module features	7
2.3	Front view	8
3	Safety	10
3.1	Intended use	10
3.2	Safety regulations	11
3.2.1	Use of qualified personnel	11
3.2.2	Warranty and liability	11
3.2.3	Disposal	11
4	Function description	12
4.1	Block diagram	12
4.2	Module features	12
4.2.1	Functions	12
4.2.2	Integrated protection mechanisms	13
4.3	Configuration	13
4.3.1	Current range	13
4.3.2	Data formats	14
4.3.3	Scaling	15
4.3.3.1	DAC raw value	16
4.3.3.2	Hardware calibration	16
4.3.3.3	Manufacturer scaling	17
4.3.3.4	User scaling	18
4.3.3.5	Example calculation	18
4.3.4	Switch-on value	19
4.3.5	Summary and overview	20
4.3.6	PSSu assignment in system environment A	20
4.3.6.1	Addresses in the process image	20
4.3.7	PSSu assignment in system environment B	21
5	Installation	22
5.1	General installation guidelines	22
5.1.1	Dimensions	22
5.2	Installing the base module	24
5.3	Inserting and removing an electronic module	25
5.3.1	Inserting an electronic module	26
5.3.2	Removing an electronic module	27
5.3.3	Changing an electronic module during operation	27

6	Wiring	28
6.1	General wiring guidelines.....	28
6.1.1	Mechanical connection of the base modules	28
6.2	Terminal configuration.....	30
6.3	Connecting the module	32
7	Operation	33
7.1	Messages.....	33
7.2	Display elements.....	34
7.2.1	Display elements for module diagnostics.....	34
7.2.2	Display elements for output status.....	34
8	Technical details	35
9	Supplementary data	38
9.1	Permitted operating height.....	38
10	Order reference	39
10.1	Product.....	39
10.2	Accessories.....	39

1 Introduction

1.1 Validity of documentation

This documentation is valid for the products PSSu E S 2AO I and PSSu E S 2AO I-T. It is valid until new documentation is published.

This operating manual explains the function and operation, describes the installation and provides guidelines on how to connect the product.

Electronic module with analogue outputs for standard applications

1.1.1 Retaining the documentation

This documentation is intended for instruction and should be retained for future reference.

1.1.2 Terminology: System environment A and B

The PSSu system can be used in two different system environments. The module's application area is described in the chapter "Intended Use" of the manual.

The distinction is made between

- ▶ PSSu in system environment A
- ▶ PSSu in system environment B

The distinction is based on the application area of the PSSu system.

PSSu in system environment A may be used in the

- ▶ Decentralised system PSSu I/O
- ▶ **Not** in the automation system PSS 4000

PSSu in system environment B may be used in the

- ▶ Automation system PSS 4000, e.g. with
 - Decentralised system PSSu I/O with SafetyNET p
 - Control system PSSu PLC
 - Control system PSSu multi

1.2 Definition of symbols

Information that is particularly important is identified as follows:



DANGER!

This warning must be heeded! It warns of a hazardous situation that poses an immediate threat of serious injury and death and indicates preventive measures that can be taken.



WARNING!

This warning must be heeded! It warns of a hazardous situation that could lead to serious injury and death and indicates preventive measures that can be taken.



CAUTION!

This refers to a hazard that can lead to a less serious or minor injury plus material damage, and also provides information on preventive measures that can be taken.



NOTICE

This describes a situation in which the product or devices could be damaged and also provides information on preventive measures that can be taken. It also highlights areas within the text that are of particular importance.



INFORMATION

This gives advice on applications and provides information on special features.

2 Overview

2.1 Module structure

A module consists of

- ▶ Electronic module and
- ▶ Base module with
 - Screw terminals or
 - Cage clamp terminals

The base modules are the carrier units for the electronic modules and are used to connect the field wiring. The electronic modules are inserted on to the base modules and determine the module's function.

Details of the base modules that can be used are available in the chapter entitled “Intended Use”.

2.2 Module features

The product has the following features:

- ▶ 2 analogue current outputs
- ▶ Configurable current ranges:
 - 0 ... 20 mA single-pole, referenced to earth (single-ended)
 - 4 ... 20 mA single-pole, referenced to earth (single-ended)
- ▶ Resolution: 12 Bit
- ▶ LEDs for:
 - Operating status per output
 - Module error
- ▶ For standard applications in system environment A and B
- ▶ T-type:
 - PSSu E S 2AO I-T: for increased environmental requirements

2.3 Front view

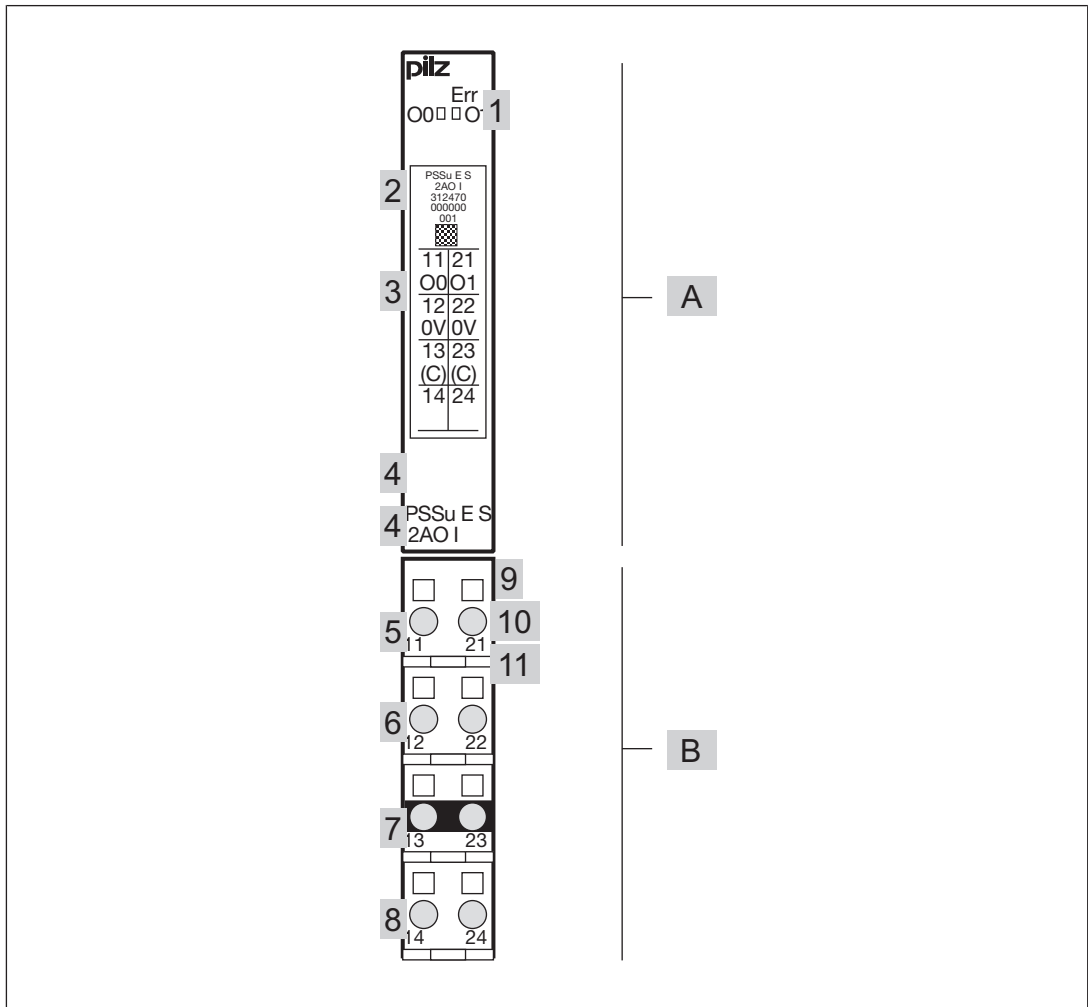

Legend:

- ▶ A: Electronic module
- ▶ B: Base module
- ▶ 1: LEDs for
 - Module diagnostics
 - Status indicator
- ▶ 2: Labelling strip with:
 - Name of electronic module
 - Order number
 - Serial number
 - Hardware version number
 - 2D code
- ▶ 3: Labelling strip for the terminal configuration on the base module
- ▶ 4: Name of electronic module
- ▶ 5: Connection level 1
- ▶ 6: Connection level 2

- ▶ 7: Connection level 3
- ▶ 8: Connection level 4
- ▶ 9: Square mounting holes (connection levels 1, 2, 3 and 4)
 - With screw to loosen/tighten the screw terminal on base modules with screw terminals
 - With mechanism to operate the cage clamp on base modules with cage clamp terminals
- ▶ 10: Round connection holes (connection levels 1, 2, 3 and 4) for connecting the signal lines
- ▶ 11: Mounting slot for colour marker to label the connection level (connection levels 1, 2, 3 and 4)

3 Safety

3.1 Intended use

The module may be used for standard applications in system environment A and B.

The module provides analogue outputs. It may be used as an output module for standard functions.

The module PSSu E S 2AO I-T is suitable for use where there are increased environmental requirements (see [Technical details](#) [ 35]).

With reference to the standard IEC 61131-2 the values stated in the technical details for ambient temperature are reduced at heights >2000 m operating height above sea level (see [Supplementary data](#) [ 38]).

Intended use includes making the electrical installation EMC-compliant. Please refer to the guidelines stated in the "PSSuniversal Installation Manual". The module is designed for use in an industrial environment. It is not suitable for use in a domestic environment, as this can lead to interference.

The following is deemed improper use in particular:

- ▶ Any component, technical or electrical modification to the module
- ▶ Use of the module outside the areas described in this manual
- ▶ Any use of the module that is not in accordance with the technical details.



INFORMATION

The module is supported by

- ▶ PSSuniversal Configurator and PSSuniversal Assistant from Version 1.4.0
- ▶ PAS4000 from Version 1.0.0
 - We recommend that you always use the latest version (download from www.pilz.com).

The PSSu E S 2AO I module may be used in conjunction with the following base modules:

- ▶ PSSu BP 1/8 S
- ▶ PSSu BP 1/8 C
- ▶ PSSu BP 1/12 S
- ▶ PSSu BP 1/12 C
- ▶ PSSu BP-C 1/8 S
- ▶ PSSu BP-C 1/8 C
- ▶ PSSu BP-C 1/12 S
- ▶ PSSu BP-C 1/12 C

The module PSSu E S 2AO I-T may be used in conjunction with the following base modules:

- ▶ PSSu BP 1/8 S-T
- ▶ PSSu BP 1/8 C-T
- ▶ PSSu BP 1/12 S-T
- ▶ PSSu BP 1/12 C-T
- ▶ PSSu BP-C 1/8 S-T
- ▶ PSSu BP-C 1/8 C-T
- ▶ PSSu BP-C 1/12 S-T
- ▶ PSSu BP-C 1/12 C-T

3.2 Safety regulations

3.2.1 Use of qualified personnel

The products may only be assembled, installed, programmed, commissioned, operated, maintained and decommissioned by persons who are competent to do so.

A competent person is a qualified and knowledgeable person who, because of their training, experience and current professional activity, has the specialist knowledge required. To be able to inspect, assess and operate devices, systems and machines, the person has to be informed of the state of the art and the applicable national, European and international laws, directives and standards.

It is the company's responsibility only to employ personnel who

- ▶ Are familiar with the basic regulations concerning health and safety / accident prevention,
- ▶ Have read and understood the information provided in the section entitled Safety
- ▶ Have a good knowledge of the generic and specialist standards applicable to the specific application.

3.2.2 Warranty and liability

All claims to warranty and liability will be rendered invalid if

- ▶ The product was used contrary to the purpose for which it is intended,
- ▶ Damage can be attributed to not having followed the guidelines in the manual,
- ▶ Operating personnel are not suitably qualified,
- ▶ Any type of modification has been made (e.g. exchanging components on the PCB boards, soldering work etc.).

3.2.3 Disposal

- ▶ In safety-related applications, please comply with the mission time T_M in the safety-related characteristic data.
- ▶ When decommissioning, please comply with local regulations regarding the disposal of electronic devices (e.g. Electrical and Electronic Equipment Act).

4 Function description

4.1 Block diagram

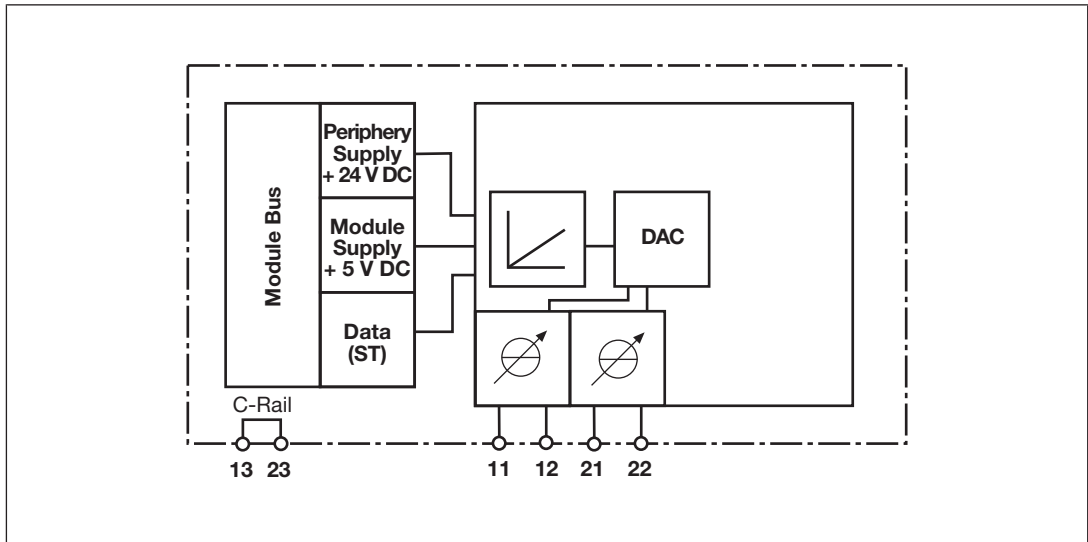

4.2 Module features

4.2.1 Functions

Module supply

- ▶ The module supply provides the module with voltage.

Periphery supply

- ▶ The supply for the outputs is generated from the periphery supply.
- ▶ The periphery supply and the outputs are galvanically isolated.

The output signals for each output are transmitted to the output module via the ST module bus. The resolution is 12 bits (4095 steps). Additional signal processing can be defined using the system software (see schematic representation of signal processing). The individual steps are described in the "Configuration" section.

All the configuration data is stored in the head module and is assigned to the output module on restart. This way the configuration data is retained even if you change the output module.

Schematic representation of signal processing:

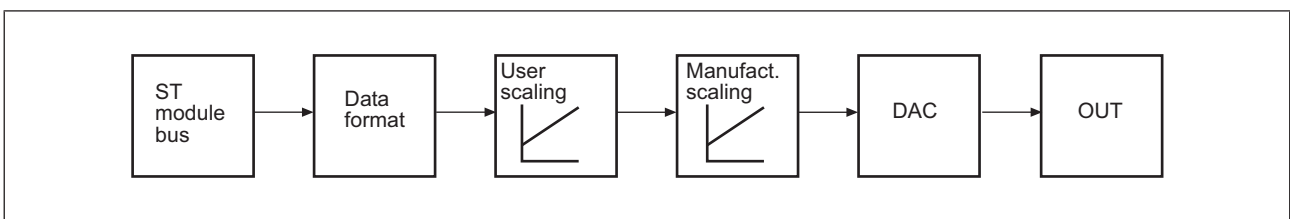

4.2.2 Integrated protection mechanisms

When the PSSu E F PS1(-T) or PSSu E F PS2(-T)(-R) is used to supply the system, the module supply is buffered for 20 ms if the supply voltage is interrupted.

The module detects the following errors:

- ▶ Start-up error
- ▶ Configuration error
- ▶ ST communication error
- ▶ Bus termination error

4.3 Configuration

The following options exist for configuring the module in system environment A:

- ▶ Via a fieldbus without the modular device description file
Without the modular device description file it is only possible to configure the input or output range. All other configuration details have default values.
- ▶ Via a fieldbus with the modular device description file
With a modular device description file it is possible to configure all the values.
- ▶ Via the USB port of the head module, using the PSSuniversal Configurator
All the values can be configured using the PSSuniversal Assistant. Any configuration via the USB port will overwrite the configuration made via the fieldbus.

If a module has been configured via the head module's USB port, it is locked and cannot be overwritten by the fieldbus. This lock can be deactivated again in the PSSuniversal Configurator.

The following options exist for configuring the module in system environment B:

- ▶ Via the head module's USB port with PAS4000.

4.3.1 Current range

You can configure the following current ranges per module:

- ▶ 0 ... 20 mA single-pole, referenced to earth (single-ended)
- ▶ 4 ... 20 mA single-pole, referenced to earth (single-ended)

4.3.2 Data formats

The way in which the analogue value is displayed depends on the voltage range, on scaling and on the data format. The following examples show the relationship between the values with default scaling.

You can configure the following data formats:

- ▶ Two's complement (default)
The digital values are transferred with 15 bits plus a sign bit (MSB). The MSB is "1" with negative values and "0" with positive values.
- ▶ Sign and magnitude representation
The digital values are transferred with 15 bits plus a sign bit (MSB). The MSB is "1" with negative values and "0" with positive values. With negative values there is a distinction between sign and magnitude representation and two's complement representation.
- ▶ Formation of magnitude option
Negative digital values are converted into positive values of equal magnitude.

As the module's resolution is 12 bits plus sign bit, the three least significant bits have no significance for the analogue value.

Analogue value and typical digital value with a current range of 0 ... 20 mA, two's complement or sign and magnitude representation:

Analogue value of current	Decimal digital value	Binary digital value	Hexadecimal digital value
0 mA	0	0000 0000 0000 0000	0000 _H
10 mA	16 384	0100 0000 0000 0000	4000 _H
20 mA	32 767	0111 1111 1111 1111	7FFF _H

Analogue value and typical digital value with a current range of 4 ... 20 mA, two's complement or sign and magnitude representation:

Analogue value of current	Decimal digital value	Binary digital value	Hexadecimal digital value
4 mA	0	0000 0000 0000 0000	0000 _H
12 mA	16 384	0100 0000 0000 0000	4000 _H
20 mA	32 767	0111 1111 1111 1111	7FFF _H

4.3.3 Scaling

Scaling is a multi-stage process to adapt the values to the DA converter. The straight path in the diagram indicates the default configuration.

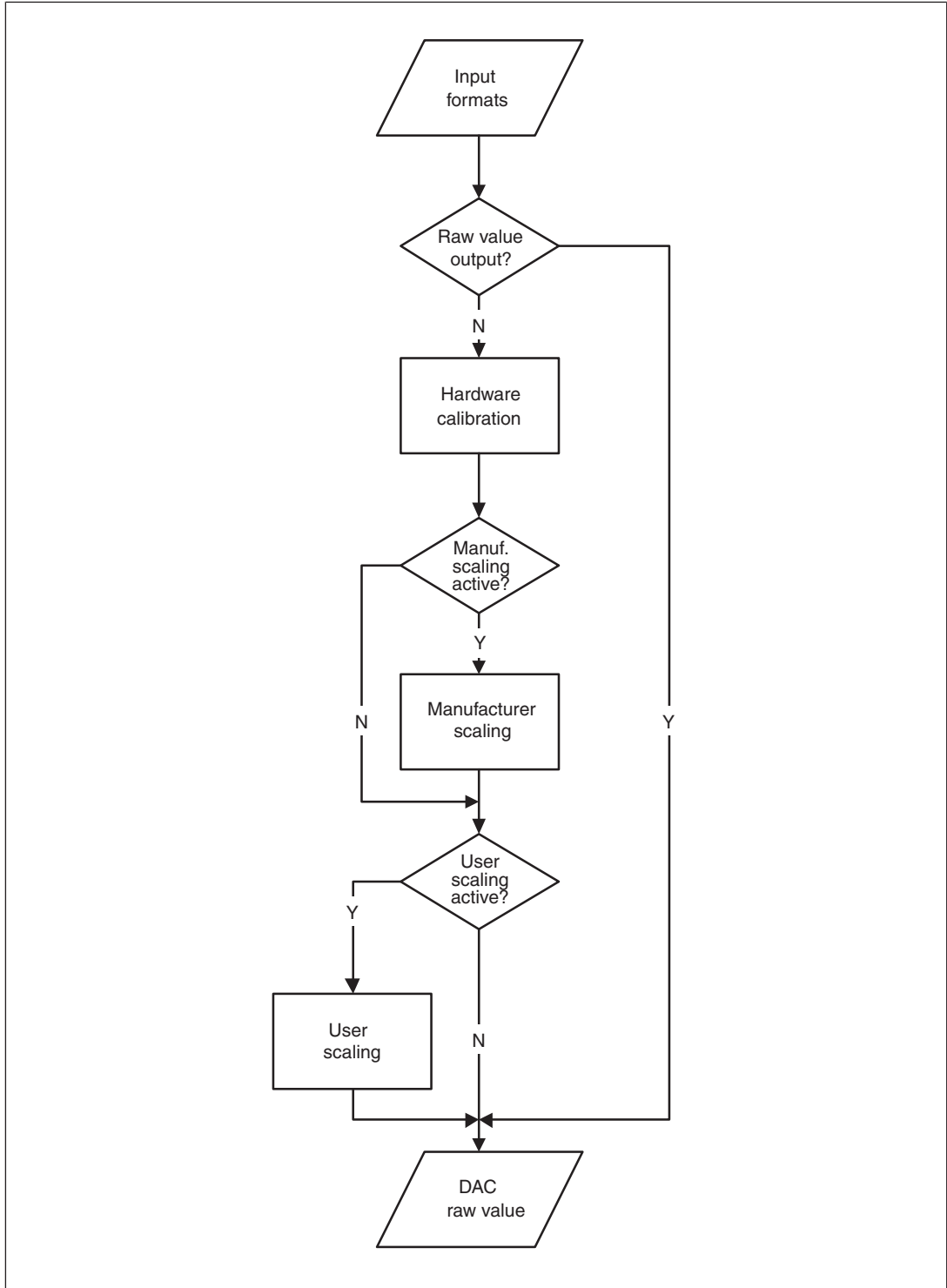

Analogue value and typical digital value with a current range of 0 ... 20 mA and default values:

Analogue value of current	Decimal digital value
0 mA	0
10 mA	16 384
20 mA	32 767

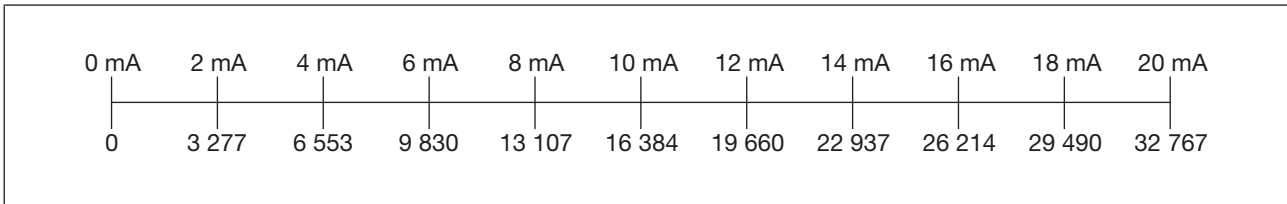

Analogue value and typical digital value with a current range of 4 ... 20 mA and default values:

Analogue value of current	Decimal digital value
4 mA	0
12 mA	16 384
20 mA	32 767

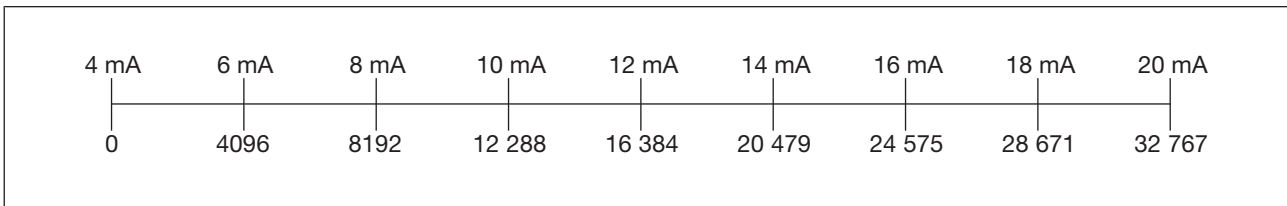

4.3.3.1 DAC raw value

You can configure each channel so that the raw value is transferred directly to the DA converter, without calibration or scaling.

4.3.3.2 Hardware calibration

Each channel is calibrated ex-works in order to correct component dispersion and other influences.

The range is divided so that zero is assigned the value 0 and the end point is assigned the value 4095_D (0FFF_H).

4.3.3.3 Manufacturer scaling

The manufacturer scaling is used to define the offset (zero point compensation) and gain (amplification) of the digital signal.

Manufacturer scaling active (default setting)

- ▶ Default values for manufacturer scaling:
 - Offset (b_1): 0
 - Gain (a_1): 32_D (20_H)



INFORMATION

The default setting for gain (a_1) means an amplification factor of 0.125 (1/8).

The digital value after manufacturer scaling is calculated using the following formula:

- ▶ $y = (a_1 / 256_D * x) + b_1$ or
- ▶ $y = (a_1 / 100_H * x) + b_1$

Key:

- ▶ **y**: Digital value after manufacturer scaling
- ▶ **x**: Digital value before manufacturer scaling
- ▶ **a_1** : Gain
- ▶ **b_1** : Offset
- ▶ **$a_1 / 256_D$** : Amplification factor



INFORMATION

With the given amplification factor, gain (a_1) is calculated as follows:

Gain (a_1) = Amplification factor * 256_D

Amplification by 5 % is therefore:

$1.05 * 256_D = 269_D$

Arithmetic examples using decimal values:

Digital value before manufacturer scaling (x)	Gain (a ₁)	Offset (b ₁)	Amplification factor (a ₁ / 256 _D)	Value after manufacturer scaling (y)
1 000	256	0	1	1 000
1 000	512	0	2	2 000
1 000	32	0	0,125	125
1 000	269	500	1,05	1 550
1 000	128	-50	0,5	450

The module always uses two's complement representation for internal processing, irrespective of the configured data format. The values from 0000_H to FFFF_H form a number circle in the two's complement representation. 8000_H follows 7FFF_H (= 32 767_D) and is interpreted as the lowest negative number (= -32 768_D). 32 767_D is never exceeded; the value never falls below -32,768_D.



INFORMATION

If 7FFF_H is exceeded as a result of scaling, unintended values may be set on the output.

4.3.3.4 User scaling

User scaling is an additional scaling level prior to manufacturer scaling. You can use this scaling to correct local influences. The function is the same as that of manufacturer scaling:

$$y = (a_2 / 256_D * x) + b_2 \text{ or}$$

$$y = (a_2 / 100_H * x) + b_2$$

$$a_2 = \text{Amplification factor} * 256_D$$

User scaling is deactivated in the default setting. The default value for offset is 0. The default value for gain is 256_D (100_H). That corresponds to amplification factor 1.

4.3.3.5 Example calculation

Task:

If the PIO shows a decimal value of 20 000, there should be 20 mA at the output. User scaling should be used in this case (Gain a₂). Manufacturer scaling should not be changed. All numbers are decimals.

Solution:

User scaling

$$y = (a_2 / 256 * x) + b_2$$

and manufacturer scaling

$$y = (a_1 / 256 * x) + b_1$$

act consecutively, giving:

$$y = (a_1 / 256 * ((a_2 / 256 * x) + b_2)) + b_1 \text{ or:}$$

$$y = (a_1 * a_2 * x / 65536) + (a_1 * b_2 / 256) + b_1$$

With default values for $a_1 = 32$, $b_1 = 0$ and the default value $b_2 = 0$:

$$y = a_2 * x / 2048$$

$$a_2 = y * 2048 / x$$

Due to the hardware calibration the converter's output range is divided so that the 20 mA end point is assigned the value $x = 4095$. With the default values $y = 4095$ and $x = 20,000$ the result is:

$$\text{Gain } a_2 = 419$$

4.3.4 Switch-on value

When the PSSuniversal is switched on, the output assumes the switch-on value until the module receives data for the value of the output. You can configure the outputs per channel with the manufacturer switch-on value (default) or you can use a freely definable user switch-on value. The manufacturer switch-on value is:

- ▶ 0 mA for the current range 0 ... 20 mA and
- ▶ 4 mA for the current range 4 ... 20 mA.

If the module does not receive any data from the module bus for 50 ms, the outputs are reset to the switch-on value.

Switch-on values are entered in the system software as decimal values. With default scaling, the decimal value (n) is calculated from the analogue value at the output (I_{Start}) as follows:

- ▶ Current range 0 ... 20 mA:
 $n = 32\,767 * I_{\text{Start}} / 20 \text{ mA}$
- ▶ Current range 4 ... 20 mA:
 $n = 32\,767 * (I_{\text{Start}} - 4 \text{ mA}) / 16 \text{ mA}$

example:

- ▶ Switch-on values as an analogue value at the output (I_{Start}):
 - Switch-on value for channel 1 is to be 8 mA.
 - Switch-on value for channel 2 is to be 15 mA.
- ▶ Entry in the system software at
Current range 0 ... 20 mA:
 - Switch-on value 1 corresponds to 13 107
 - Switch-on value 2 corresponds to 24 576
- ▶ Entry in the system software at
Current range 4 ... 20 mA:
 - Switch-on value 1 corresponds to 8 192
 - Switch-on value 2 corresponds to 22 528

The relationship between the switch-on value and the actual current at the output is dependent on the scaling. The module sets the current, which corresponds to the switch-on voltage after scaling. Please refer to the "Scaling" section in this manual.

4.3.5 Summary and overview

The module has the following configuration options:

Configurable properties	Default value	Meaning
Output range	0	0 mA ... 20 mA (1 = 4 mA ... 20 mA)
Manufacturer scaling active	1/TRUE	Activated
Manufacturer scaling offset	0	Offset: Magnitude 0
Manufacturer scaling gain	32 _D	Amplification by 1/8, displaced three bit places
User scaling active	0/FALSE	Deactivated
User scaling offset	0	Offset: Magnitude 0
User scaling gain	256 _D	1x amplification, signal unchanged
Switch-on value active	0/FALSE	Manufacturer switch-on value active (1/TRUE = User switch-on value active)
Manufacturer switch-on value	0	0 mA / 4 mA on switch-on
User switch-on value	0	0 mA / 4 mA on switch-on
Sign and magnitude representation active	0/FALSE	Deactivated; two's complement is activated
Formation of magnitude active	0/FALSE	Deactivated
Output DAC raw value only	0/FALSE	Deactivated

4.3.6 PSSu assignment in system environment A

4.3.6.1 Addresses in the process image

Each output channel occupies 16 consecutive bit addresses for the output data.

Configuration	Standard bus system	
	ST-P11	ST-PIO
None	---	32 Bit

Bit sequence in the PIO:

Input	PIO	Assignment
Output O0	1	LSB

	16	MSB
Output O1	17	LSB

	32	MSB

4.3.7 PSSu assignment in system environment B

Data access is via pre-defined I/O data types:

I/O data name	I/O data type	I/O data element	Meaning
O0(11), O1(21)	ST_O_AO	Data: WORD	Output data O0, O1

5 Installation

5.1 General installation guidelines

Please also refer to the PSSuniversal Installation Manual.



NOTICE

Damage due to electrostatic discharge!

Electrostatic discharge can damage components. Ensure against discharge before touching the product, e.g. by touching an earthed, conductive surface or by wearing an earthed armband.

5.1.1 Dimensions

Base modules with four connection levels:

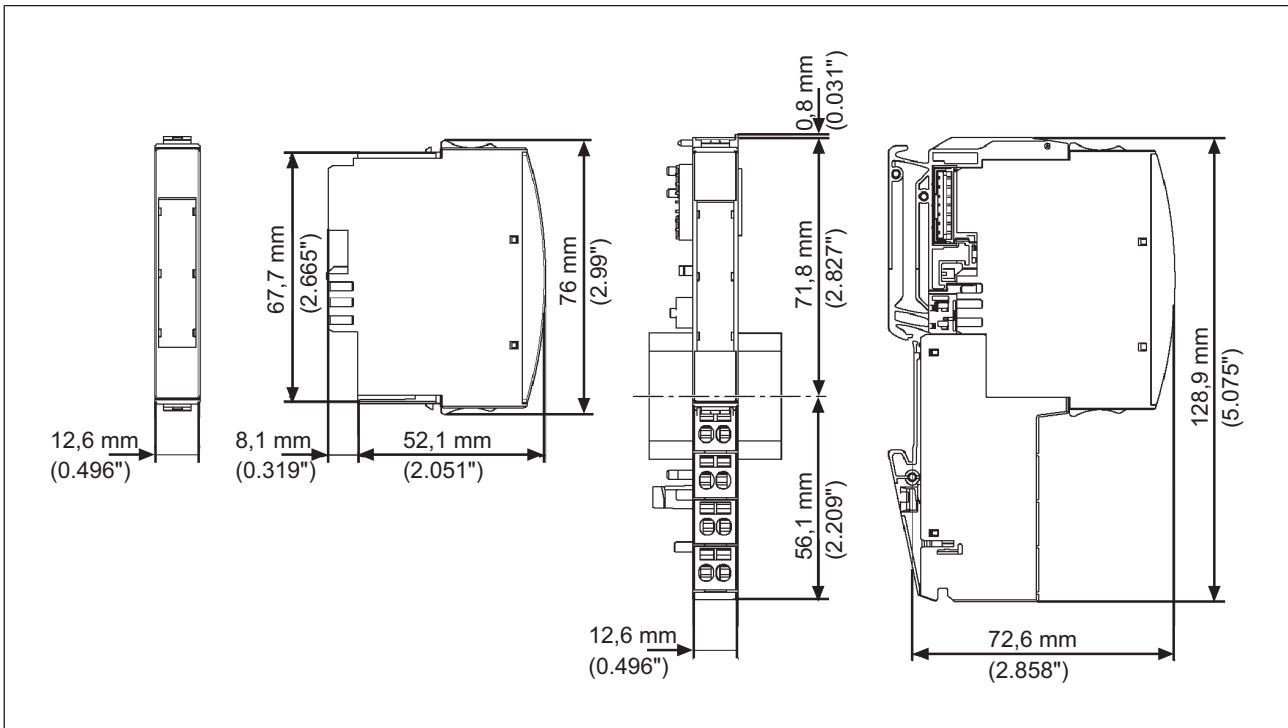

Base modules with six connection levels:

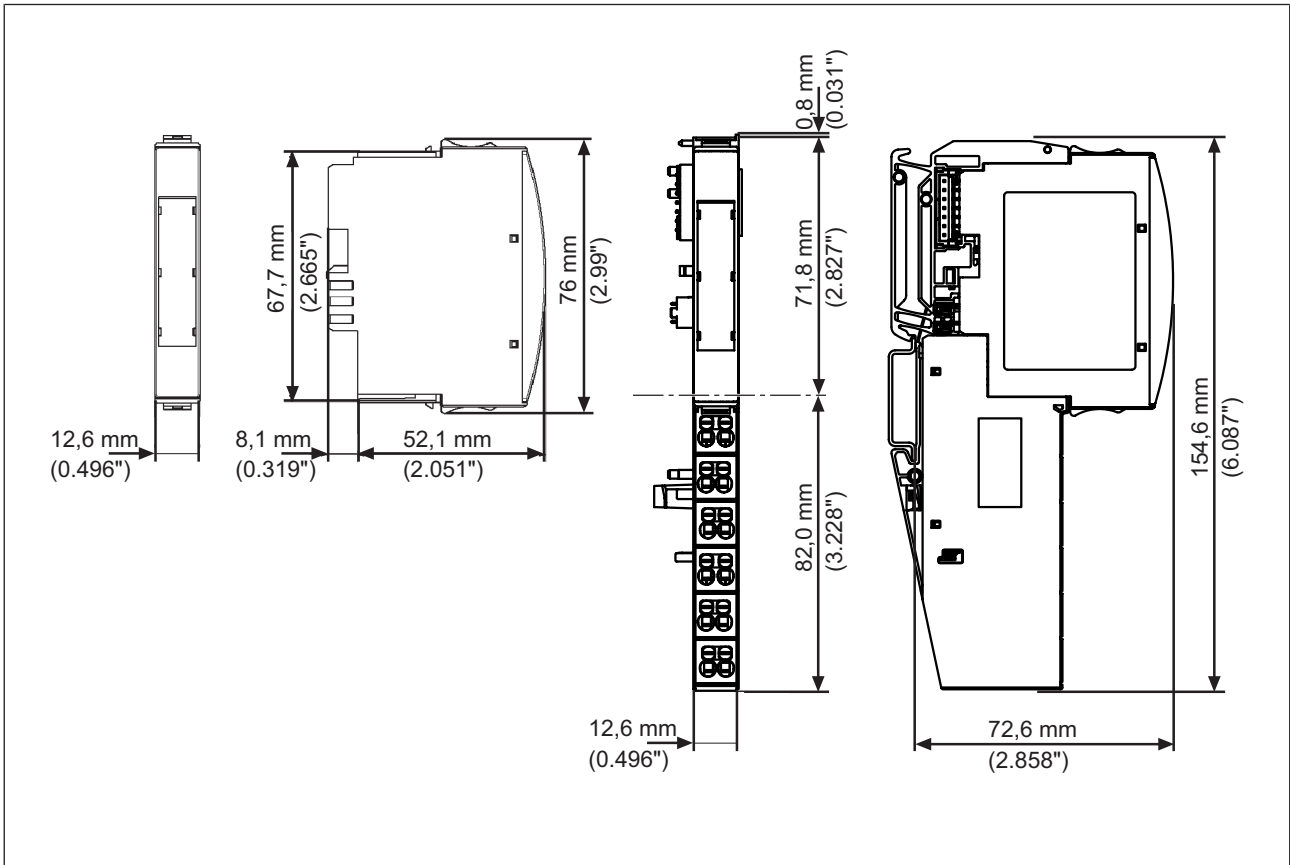

5.2 Installing the base module

Prerequisite:

- ▶ The head module must be installed.
- ▶ If the head module does not have an integrated power supply, a supply voltage module must be installed to the right of the head module.

Please note:

- ▶ For mechanical reasons it is not possible to mix base modules with screw terminals and base modules with cage clamp terminals.
- ▶ All contacts should be protected from contamination.
- ▶ The mechanics of the base modules are designed for 50 plug in/out cycles.

Procedure:

- ▶ We recommend that you wire up the base modules before inserting the electronic modules.
- ▶ Slot the groove on the base module on to the mounting rail from below [1].
- ▶ Push the base module back [2] until you hear it lock into position.
- ▶ On the mounting rail, slide the base module to the left until you hear the two lateral mounting hooks on the adjacent module lock into position [3].

Schematic representation:

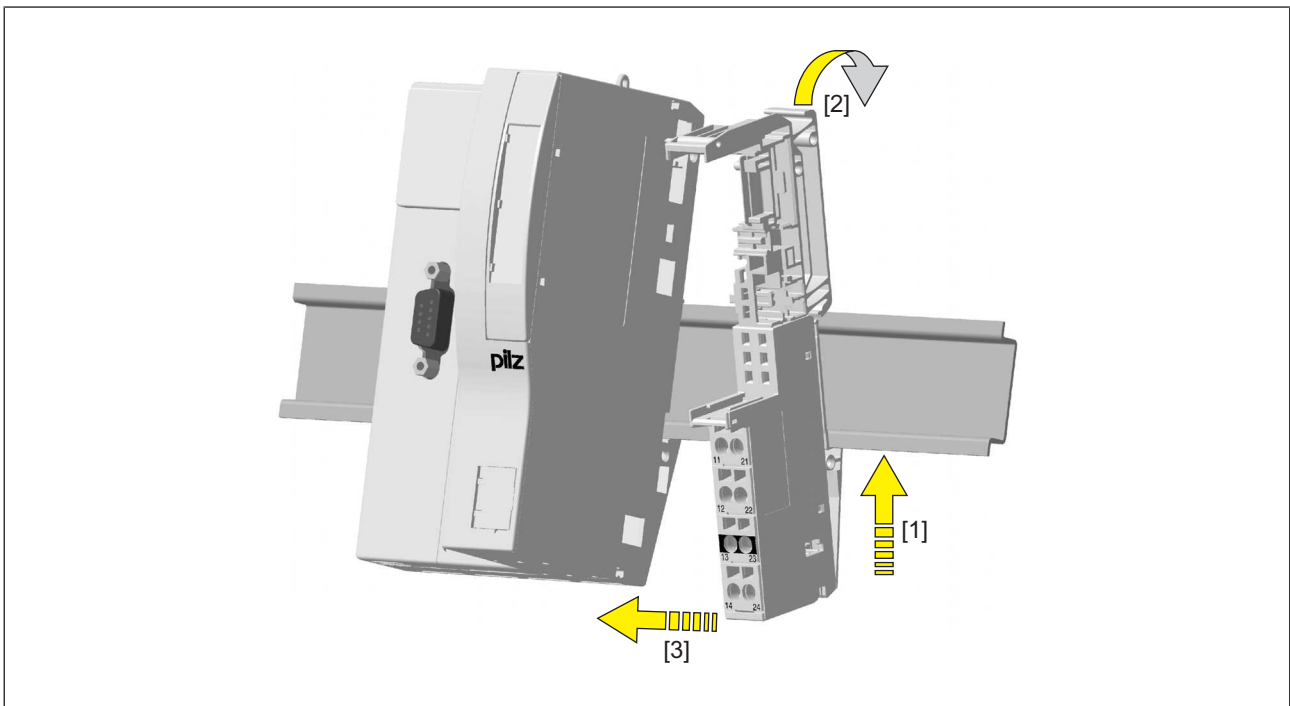

5.3 Inserting and removing an electronic module

Please note:

- ▶ Only insert on to base modules that are already installed.
- ▶ Preferably these base modules should be ready wired.
- ▶ Electronic modules with outputs may only be inserted and removed when the load is switched off. Unforeseeable error reactions may be triggered if modules are inserted and removed under load.
- ▶ When an electronic module is plugged into a base module for the first time, one part of the coding element remains on the electronic module, while its counterpart is fixed on to the base module. This is how the base module is coded.
- ▶ The mechanics of the electronic modules are designed for 50 plug in/out cycles.

5.3.1 Inserting an electronic module

Procedure:

- ▶ The electronic module must audibly lock into position [1].
- ▶ Mark the electronic module using the labelling strips [2].

Schematic representation:

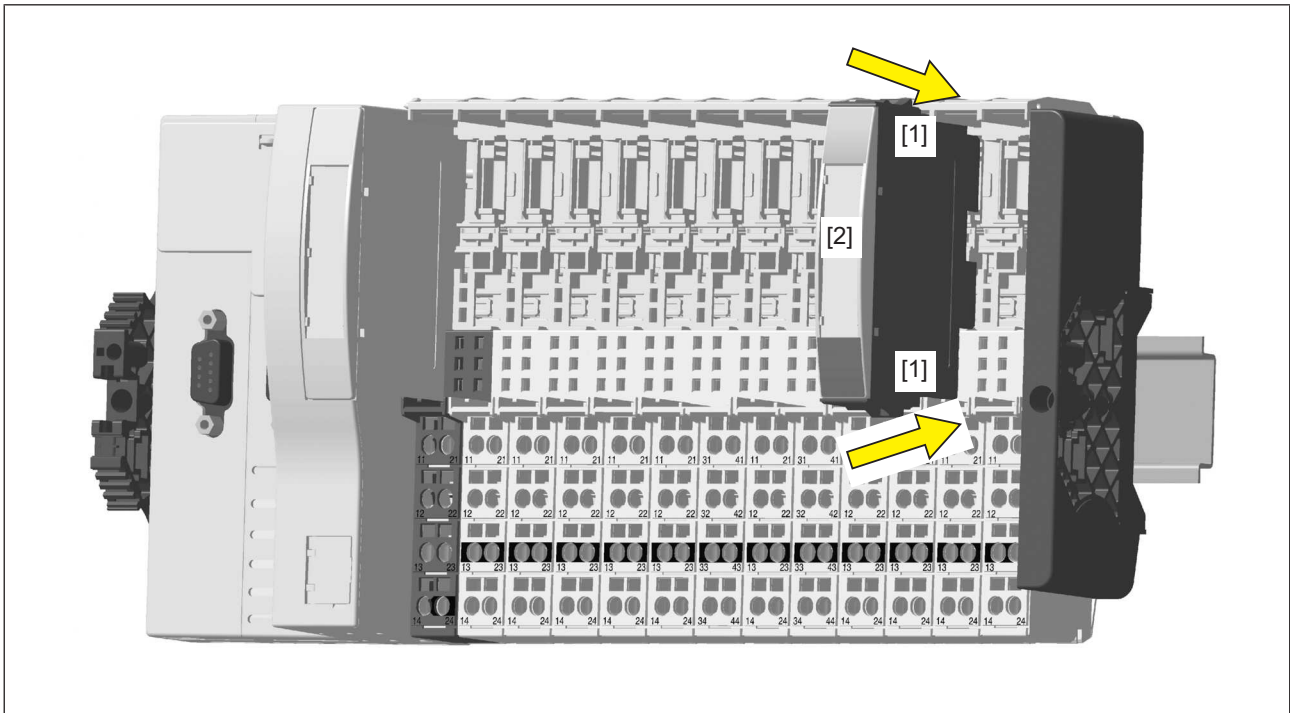

5.3.2 Removing an electronic module

Procedure:

- ▶ Press the locking mechanisms [1] together simultaneously.
- ▶ Pull out the electronic module [2].

Schematic representation:

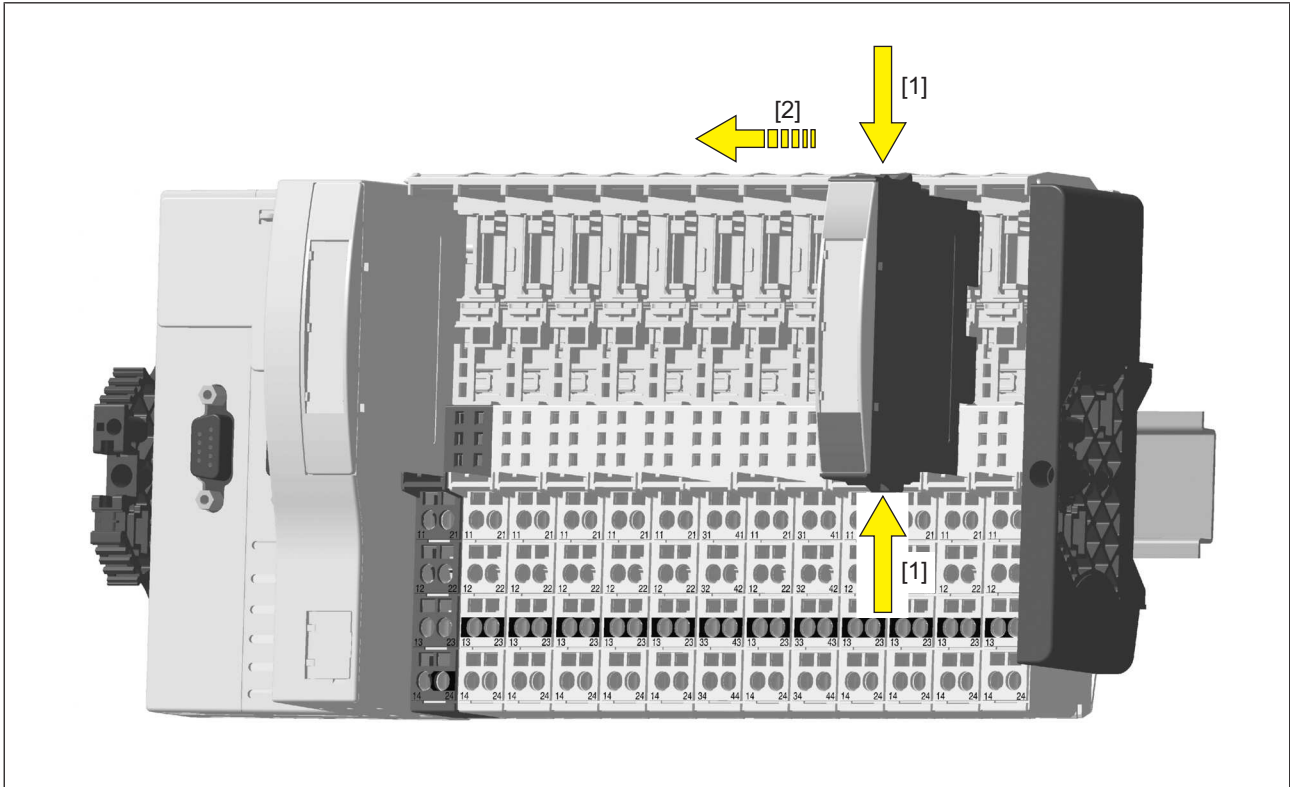

5.3.3 Changing an electronic module during operation

It is possible to change an electronic module during operation. The configuration data is retained when a module is changed.

Effects:

- ▶ System environment A:
 - In the event of a potential FS communication error, the FS section of the PSSu system and all relevant I/O-Groups (SafetyBUS p) switch to a STOP condition.
- ▶ System environment B:
 - All FS hardware outputs on the PSSu system switch to a safe condition.
 - The substitute values are used for the modules' FS outputs, with Valid Bits = FALSE.



CAUTION!

Sparking can cause interference and errors!

Only change the module when the load is switched off!

6 Wiring

6.1 General wiring guidelines

Please note:

- ▶ The supply voltages for actuators and sensors must be extra low voltages with protective electrical separation (PELV or SELV) in accordance with VDE 0100, Part 410. Failure to do so could result in electric shock.
- ▶ We recommend that you use shielded signal lines.
- ▶ On base modules with C-rail:
 - Connect the shield to the terminals on the C-rail.
 - Connect the C-rail with low impedance to the functional earth.
- ▶ On base modules without C-rail:
 - Connect the shield as shown in the terminal configuration section.
The module connects the shield to the mounting rail.
 - Connect the mounting rail to the functional earth via an earthing terminal.
- ▶ In environments with strong EMC interference, base modules without a C-rail provide better protection if the shield is connected.
- ▶ Use copper wiring.
- ▶ The terminal configuration as stated on the front plate applies for base modules with C-rail. The terminal configuration as stated in the technical documentation applies for all other base modules.

6.1.1 Mechanical connection of the base modules

Procedure:

- ▶ Use a flat blade screwdriver (DIN 5264-A)!

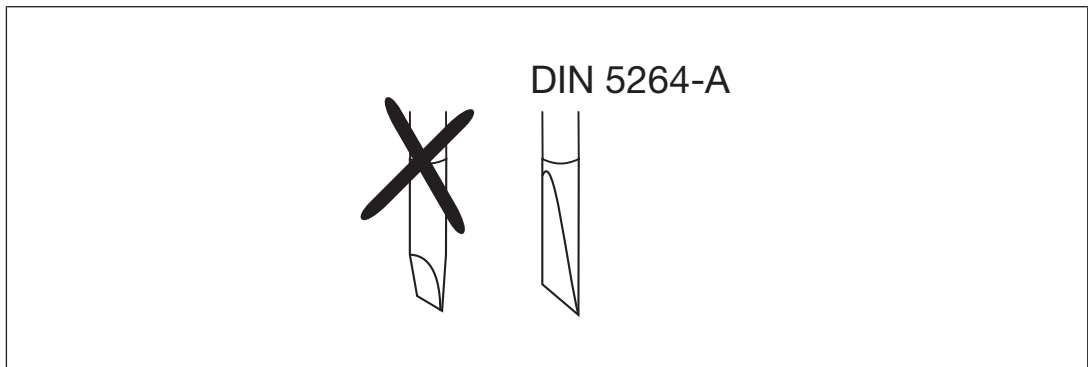

- ▶ Strip the wire back 8 mm.

- ▶ If necessary, label the connection level with a colour marker [3].
- ▶ Base module with screw terminals:
 - Use a screwdriver to loosen the screw on the screw terminal [1]
 - Insert the stripped cable into the round fixing hole [2], as far as it will go.
 - Tighten up the screw on the screw terminal.
 - Check that the cable is firmly seated.
- ▶ Base module with cage clamp terminals:
 - Insert the screwdriver [4] into the square hole [1].
 - Insert the stripped cable into the round fixing hole [2], as far as it will go [5].
 - Pull out the screwdriver [6].
 - Check that the cable is firmly seated.

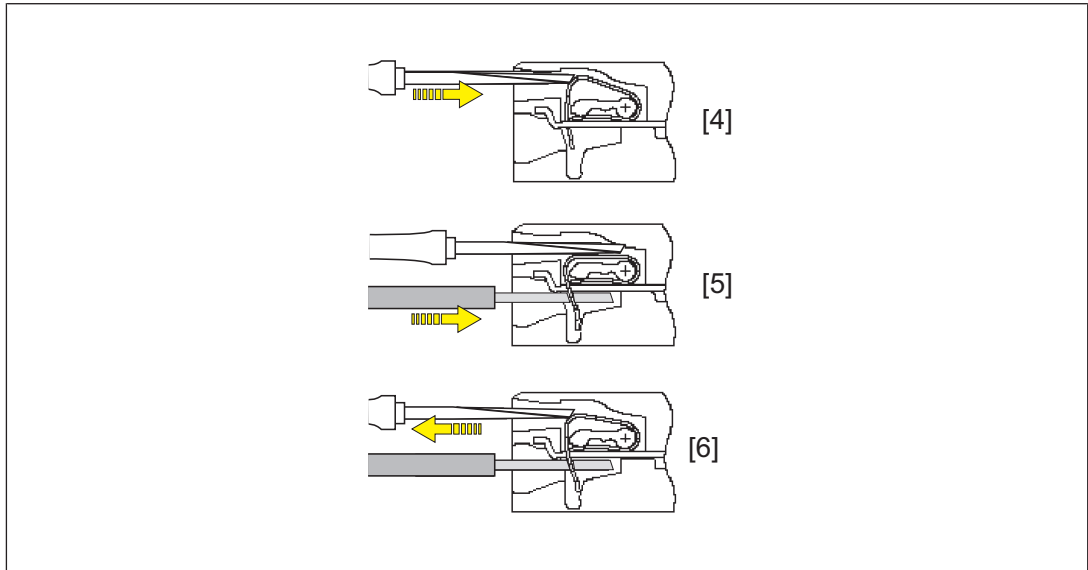
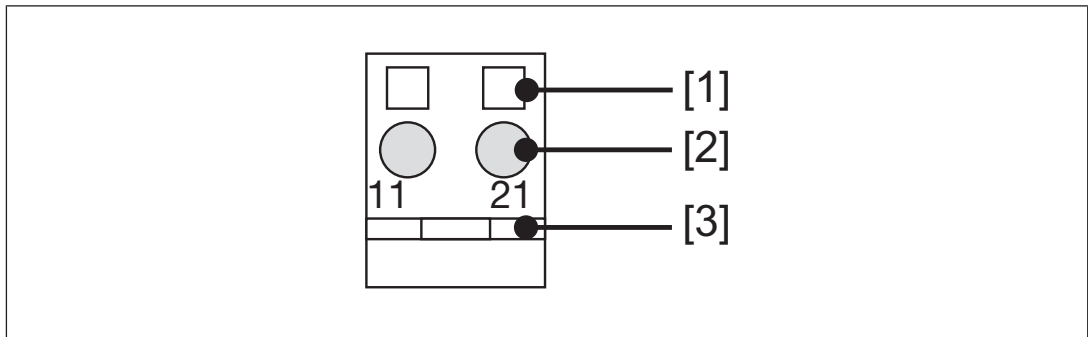

Please note:

- ▶ The minimum cable cross section for field connection terminals on the base modules is 0.14 mm² (AWG26).

- ▶ The maximum cable cross section for field connection terminals is:
 - Digital inputs: 1.5 mm² (AWG16)
 - Digital outputs: 2.0 mm² (AWG14)
 - Inputs/outputs on the counter modules: 1.5 mm² (AWG16)
 - Analogue inputs/outputs: 1.5 mm² (AWG16)
 - Communication cables: 1.5 mm² (AWG16)
 - Test pulse outputs: 1.5 mm² (AWG16)
 - Power supply: 2.5 mm² (AWG12)
 - Functional earth: 2.5 mm² (AWG12)
- ▶ On base modules with screw terminals:
 - If you use a multi-strand cable to connect the I/Os, it is recommended that you use ferrules conforming to Parts 1 and 2 of DIN 46228, 0.14 ... 1.5 mm², Form A or C, although this is not essential. To crimp the ferrules you can use crimp pliers (crimp form A or C) conforming to EN 60947-1, such as the PZ 1.5 or PZ 6.5 from Weidmüller, for example.
 - Maximum torque setting: 0.8 Nm
- ▶ Use copper wiring.

6.2 Terminal configuration

Base module	Terminal configuration	
Screw terminals: PSSu BP 1/8 S PSSu BP 1/8 S-T Cage clamp terminals: PSSu BP 1/8 C PSSu BP 1/8 C-T	Without C-rail: 11: Output O0 21: Output O1 12-22: 0 V analogue (12-22 linked within the base module) 13-23: Shield connection (13-23 linked within the base module) 14: Not connected 24: Not connected	

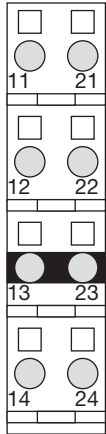
Base module	Terminal configuration	
<p>Screw terminals: PSSu BP-C 1/8 S PSSu BP-C 1/8 S-T</p> <p>Cage clamp terminals: PSSu BP-C 1/8 C PSSu BP-C 1/8 C-T</p>	<p>With C-rail:</p> <p>11: Output O0</p> <p>21: Output O1</p> <p>12-22: 0 V analogue (12-22 linked within the base module)</p> <p>13-23: C-rail supply, shield connection (13-23 linked within the base module)</p> <p>14: Not connected</p> <p>24: Not connected</p>	

6.3 Connecting the module

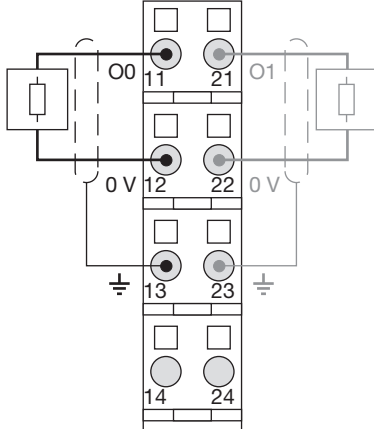
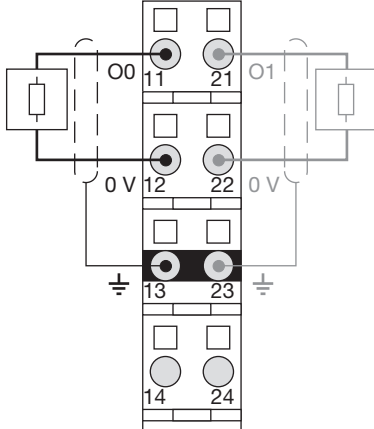
Output circuit	Without C-rail	With C-rail
<p>current range 0 ... 20 mA current range 4 ... 20 mA single-pole, referenced to earth</p>		

7 Operation

7.1 Messages

A module error is displayed via the "Err" LED (see section entitled "Display elements"). It is signalled to the head module and then entered in the

- ▶ Error stack, with PSSu in system environment A
- ▶ Diagnostic log, with PSSu in system environment B.

of the head module.

The module can detect the following errors:

Module error	Explanation	Remedy
Start-up error	Error as the PSSu system starts up	Change faulty module.
Configuration error	Incorrect module type configured.	The configured hardware registry does not match the actual hardware registry.
ST communication error	Error during ST communication	Change faulty module.
Bus termination error	There is no terminating plate or there is a bad contact with the module bus.	Install a terminating plate with integrated end bracket or insert the base modules together correctly.
Timeout error on the output	No data has been received for the output from the module bus for longer than 50 ms.	Check ST communication or configuration.



7.2 Display elements

Legend

-  LED on
-  LED off



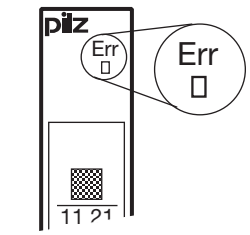

7.2.1 Display elements for module diagnostics

The module has an LED for displaying module errors ("Err" LED).

	LED			Meaning
	Name	Colour	Status	
	Err	---		No error
	Red		Module error	

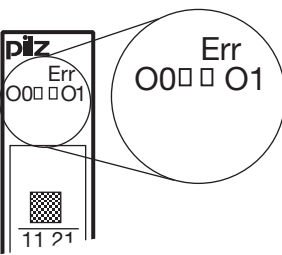
7.2.2 Display elements for output status

Each output is assigned an LED for displaying the output status (LEDs "O0" and "O1"). The green LED lights up as soon as the module receives data from the module bus that is to be output.

	LED			Meaning		
	Designation	Colour	Status	Signal	Output	Terminal
	O0	---		No signal detected	O0 (Output 1)	11
		green		Signal detected		
	O1	---		No signal detected	O1 (Output 2)	21
		green		Signal detected		

8 Technical details

General	312470	314470
Certifications	CE, UKCA, cULus Listed	CE, UKCA, cULus Listed
Application range	Standard	Standard
Module's device code	0510h	0510h
Number of ST output bits	32	32
Application in system environment A		
from ST firmware version, other head modules	7	7
from ST firmware version PSSu H S PN	1	1
from ST firmware version PSSu WR S IDN	4	4
Application in system environment B		
from ST firmware version, head modules	1.0.0	1.0.0
Electrical data	312470	314470
Internal supply voltage (module supply)		
Module's power consumption	0,22 W	0,22 W
Periphery's supply voltage (periphery supply)		
Voltage range	16,8 - 30 V	16,8 - 30 V
Module's current consumption with no load	54 mA	54 mA
Module's power consumption with no load	1,29 W	1,29 W
Max. power dissipation of module	0,5 W	0,5 W
Permitted loads	inductive, resistive	inductive, resistive
Analogue outputs	312470	314470
Number of analogue outputs	2	2
Type of analogue outputs	Current	Current
Output range	0 .. 20 mA	0 .. 20 mA
Resolution (without sign bit)	12 Bit	12 Bit
Max. open circuit voltage	14 V	14 V
Max. permitted resistive load	500 Ohm	500 Ohm
Deviations from the measuring range limit value		
Linearity error	0,15 %	0,15 %
Output variable error at 25 °C	0,3 %	0,3 %
Max. output variable error for EMC measurements at 25 °C	2 %	2 %
Temperature coefficient	0,02 %/K	0,02 %/K

Analogue outputs	312470	314470
Potential isolation between output and voltage for the internal module bus	Yes	Yes
Potential isolation between output and periphery supply	Yes	Yes
Typ. processing time of the analogue output	1 ms	1 ms
Environmental data	312470	314470
Climatic suitability	EN 60068-2-1, EN 60068-2-14, EN 60068-2-2, EN 60068-2-30, EN 60068-2-78	EN 60068-2-1, EN 60068-2-14, EN 60068-2-2, EN 60068-2-30, EN 60068-2-78
Ambient temperature		
in accordance with the standard	EN 60068-2-14	EN 60068-2-14
Temperature range	0 - 60 °C	-40 - 70 °C
Storage temperature		
in accordance with the standard	EN 60068-2-1/-2	EN 60068-2-1/-2
Temperature range	-25 - 70 °C	-40 - 70 °C
Climatic suitability		
in accordance with the standard	EN 60068-2-30, EN 60068-2-78	EN 60068-2-30, EN 60068-2-78
Humidity	93 % r. h. at 40 °C	93 % r. h. at 40 °C
Condensation during operation	Not permitted	Short-term
Max. operating height above SL	2000 m	5000 m
EMC	EN 61000-4-2, EN 61000-4-3, EN 61000-4-4, EN 61000-4-5, EN 61000-4-6, EN 61000-6-2, EN 61000-6-4	EN 61000-4-2, EN 61000-4-3, EN 61000-4-4, EN 61000-4-5, EN 61000-4-6, EN 61000-6-2, EN 61000-6-4
Vibration		
in accordance with the standard	EN 60068-2-6	EN 60068-2-6
Frequency	10 - 150 Hz	10 - 150 Hz
Amplitude	0,35 mm	0,35 mm
Acceleration	1g	1g
Broadband noise		
in accordance with the standard	–	EN 60068-2-64
Frequency	–	5 - 500 Hz
Acceleration	–	1,9grms
Shock stress		
in accordance with the standard	EN 60068-2-27	EN 60068-2-27
Number of shocks	6	6
Acceleration	15g	15g
Duration	11 ms	11 ms
in accordance with the standard	EN 60068-2-27	EN 60068-2-27
Number of shocks	1000	1000
Acceleration	10g	10g
Duration	16 ms	16 ms

Environmental data	312470	314470
Airgap creepage		
in accordance with the standard	EN 60664-1	EN 60664-1
Overvoltage category	II	II
Pollution degree	2	2
Protection type		
in accordance with the standard	EN 60529	EN 60529
Housing	IP20	IP20
Terminals	IP20	IP20
Mounting area (e.g. control cabinet)	IP54	IP54
Mechanical data	312470	314470
Material		
Bottom	PC	PC
Front	PC	PC
Coding	PA	PA
Mounting type	plug-in	plug-in
Dimensions		
Height	76 mm	76 mm
Width	12,6 mm	12,6 mm
Depth	60,2 mm	60,2 mm
Weight	36 g	38 g
Mechanical coding		
Type	E	E
Colour	Dark grey	Dark grey

Where standards are undated, the 2005-04 latest editions shall apply.

9 Supplementary data

9.1 Permitted operating height

The values stated in the technical details apply to the use of the device in operating heights up to max. 2000 m above SL. When used at higher levels, restrictions of the ambient temperature (standard IEC 61131-2) must be taken into account.

Operating height above SL [m]	Multiplication factors for the devices' ambient temperature
0 ... 2000	1.0
3000	0.9
4000	0.8
5000	0.7

10 Order reference

10.1 Product

Product type	Features	Order no.
PSSu E S 2AO I	Electronic module, base type	312470
PSSu E S 2AO I-T	Electronic module, T-type	314470

10.2 Accessories

Base modules

Product type	Features	Order no.
PSSu BP 1/8 S	Base module without C-rail with screw terminals	312600
PSSu BP 1/8 S-T	Base module without C-rail with screw terminals, T-type	314600
PSSu BP 1/8 C	Base module without C-rail with cage clamp terminals	312601
PSSu BP 1/8 C-T	Base module without C-rail with cage clamp terminals, T-type	314601
PSSu BP-C 1/8 S	Base module with C-rail and screw terminals	312610
PSSu BP-C 1/8 S-T	Base module with C-rail and screw terminals, T-type	314610
PSSu BP-C 1/8 C	Base module with C-rail and cage clamp terminals	312611
PSSu BP-C 1/8 C-T	Base module with C-rail and cage clamp terminals, T-type	314611
PSSu BP 1/12 S	Base module without C-rail with screw terminals	312618
PSSu BP 1/12 S-T	Base module without C-rail with screw terminals, T-type	314618
PSSu BP 1/12 C	Base module without C-rail with cage clamp terminals	312619
PSSu BP 1/12 C-T	Base module without C-rail with cage clamp terminals, T-type	314619
PSSu BP-C 1/12 S	Base module with C-rail and screw terminals	312620
PSSu BP-C 1/12 S-T	Base module with C-rail and screw terminals, T-type	314620
PSSu BP-C 1/12 C	Base module with C-rail and cage clamp terminals	312621
PSSu BP-C 1/12 C-T	Base module with C-rail and cage clamp terminals, T-type	314621

▶ Support

Technical support is available from Pilz round the clock.

Americas

Brazil

+55 11 97569-2804

Canada

+1 888 315 7459

Mexico

+52 55 5572 1300

USA (toll-free)

+1 877-PILZUSA (745-9872)

Asia

China

+86 21 60880878-216

Japan

+81 45 471-2281

South Korea

+82 31 778 3300

Australia and Oceania

Australia

+61 3 95600621

New Zealand

+64 9 6345350

Europe

Austria

+43 1 7986263-0

Belgium, Luxembourg

+32 9 3217570

France

+33 3 88104003

Germany

+49 711 3409-444

Ireland

+353 21 4804983

Italy, Malta

+39 0362 1826711

Scandinavia

+45 74436332

Spain

+34 938497433

Switzerland

+41 62 88979-32

The Netherlands

+31 347 320477

Turkey

+90 216 5775552

United Kingdom

+44 1536 462203

You can reach our international hotline on:

+49 711 3409-222

support@pilz.com

Pilz develops environmentally-friendly products using ecological materials and energy-saving technologies. Offices and production facilities are ecologically designed, environmentally-aware and energy-saving. So Pilz offers sustainability, plus the security of using energy-efficient products and environmentally-friendly solutions.



We are represented internationally. Please refer to our homepage www.pilz.com for further details or contact our headquarters.

Headquarters: Pilz GmbH & Co. KG, Felix-Wankel-Straße 2, 73760 Ostfildern, Germany
Telephone: +49 711 3409-0, Telefax: +49 711 3409-133, E-Mail: info@pilz.com, Internet: www.pilz.com

PILZ
THE SPIRIT OF SAFETY