



## PSSu E PS-P 5V

**PILZ**  
THE SPIRIT OF SAFETY

- ▶ Decentralised system PSSuniversal I/O

This document is the original document.

Where unavoidable, for reasons of readability, the masculine form has been selected when formulating this document. We do assure you that all persons are regarded without discrimination and on an equal basis.

All rights to this documentation are reserved by Pilz GmbH & Co. KG. Copies may be made for the user's internal purposes. Suggestions and comments for improving this documentation will be gratefully received.

Pilz®, PIT®, PMI®, PNOZ®, Primo®, PSEN®, PSS®, PVIS®, SafetyBUS p®, SafetyEYE®, SafetyNET p®, the spirit of safety® are registered and protected trademarks of Pilz GmbH & Co. KG in some countries.



SD means Secure Digital

<b>1</b>	<b>Introduction</b> .....	<b>4</b>
1.1	Validity of documentation .....	4
1.1.1	Retaining the documentation .....	4
1.2	Definition of symbols .....	4
<b>2</b>	<b>Overview</b> .....	<b>6</b>
2.1	Module structure .....	6
2.2	Module features .....	6
2.3	Front view .....	7
<b>3</b>	<b>Safety</b> .....	<b>9</b>
3.1	Intended use .....	9
3.2	Safety regulations .....	10
3.2.1	Use of qualified personnel .....	10
3.2.2	Warranty and liability .....	10
3.2.3	Disposal .....	10
<b>4</b>	<b>Function description</b> .....	<b>11</b>
4.1	Block diagram .....	11
4.2	Module features .....	11
4.2.1	Integrated protection mechanisms .....	11
4.2.2	Functions .....	11
4.3	Configuration .....	12
<b>5</b>	<b>Installation</b> .....	<b>13</b>
5.1	General installation guidelines .....	13
5.1.1	Dimensions .....	13
5.2	Installing the base module .....	15
5.3	Inserting and removing an electronic module .....	16
5.3.1	Inserting an electronic module .....	17
5.3.2	Removing an electronic module .....	18
5.3.3	Changing an electronic module during operation .....	18
<b>6</b>	<b>Wiring</b> .....	<b>19</b>
6.1	General wiring guidelines .....	19
6.1.1	Mechanical connection of the base modules .....	19
6.2	Terminal configuration .....	21
<b>7</b>	<b>Operation</b> .....	<b>24</b>
7.1	Messages .....	24
7.2	Display elements .....	24
7.2.1	Display elements for module diagnostics .....	24
<b>8</b>	<b>Technical details</b> .....	<b>25</b>
<b>9</b>	<b>Order reference</b> .....	<b>27</b>
9.1	Product .....	27
9.2	Accessories .....	27

# 1 Introduction

## 1.1 Validity of documentation

This documentation is valid for the product PSSu E PS-P 5V. It is valid until new documentation is published.

This operating manual explains the function and operation, describes the installation and provides guidelines on how to connect the product.

### 1.1.1 Retaining the documentation

This documentation is intended for instruction and should be retained for future reference.

## 1.2 Definition of symbols

Information that is particularly important is identified as follows:



### **DANGER!**

This warning must be heeded! It warns of a hazardous situation that poses an immediate threat of serious injury and death and indicates preventive measures that can be taken.



### **WARNING!**

This warning must be heeded! It warns of a hazardous situation that could lead to serious injury and death and indicates preventive measures that can be taken.



### **CAUTION!**

This refers to a hazard that can lead to a less serious or minor injury plus material damage, and also provides information on preventive measures that can be taken.



### **NOTICE**

This describes a situation in which the product or devices could be damaged and also provides information on preventive measures that can be taken. It also highlights areas within the text that are of particular importance.



**INFORMATION**

This gives advice on applications and provides information on special features.

## 2 Overview

### 2.1 Module structure

A module consists of

- ▶ Electronic module and
- ▶ Base module with
  - Screw terminals or
  - Cage clamp terminals

The base modules are the carrier units for the electronic modules and are used to connect the field wiring. The electronic modules are inserted on to the base modules and determine the module's function.

Details of the base modules that can be used are available in the chapter entitled “Intended Use”.

### 2.2 Module features

The product has the following features:

- ▶ Primary side of power supply
  - The external supply is fed to the base module terminals.
  - Voltage: 24 V
- ▶ Secondary side of power supply
  - The module supplies the output voltage to the base module terminals.
  - No buffer when the supply voltage is interrupted
  - Voltage: 5 V
  - Max. continuous output: 10 W
  - Max. current at 5 V: 2 A
- ▶ LED for:
  - External voltage

## 2.3 Front view

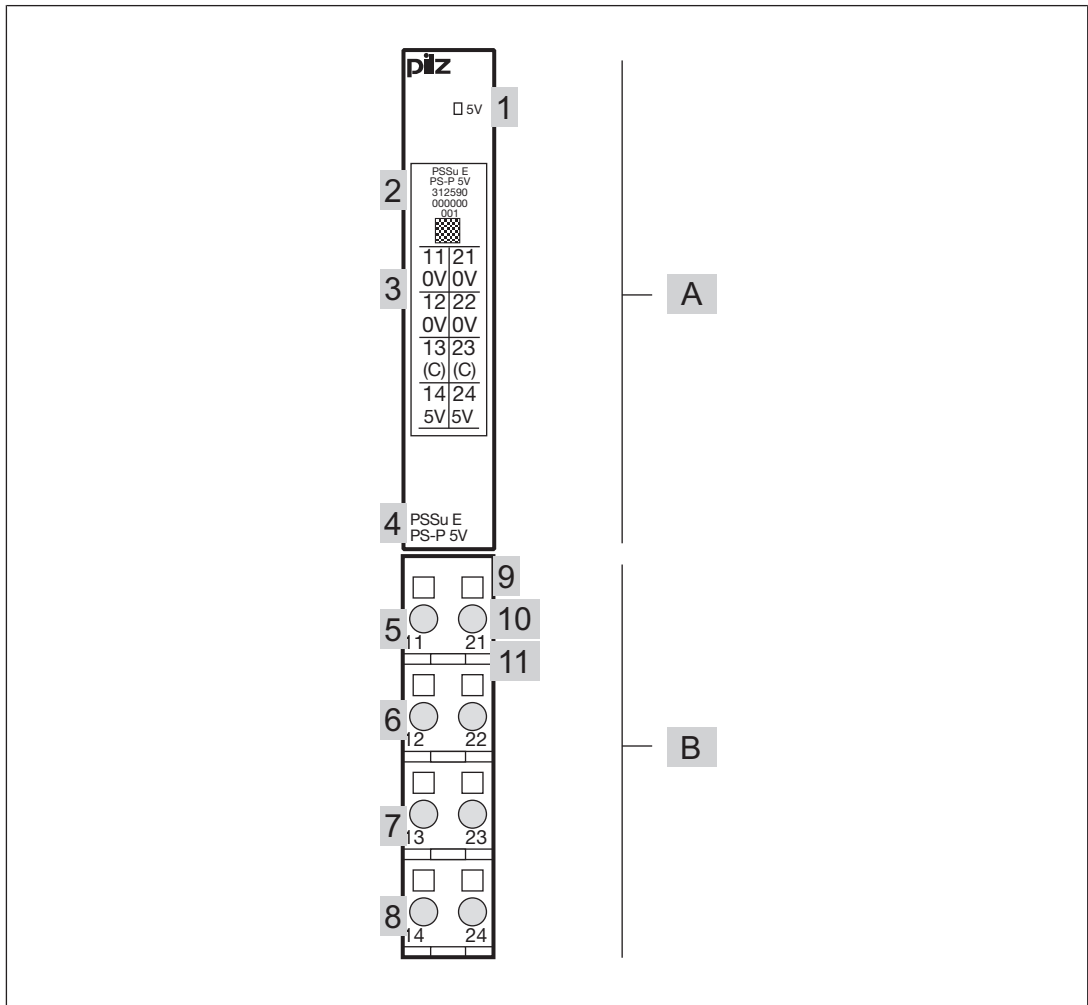

**Key:**

- ▶ A: Electronic module
- ▶ B: Base module
- ▶ 1: LED for module diagnostics
- ▶ 2: Labelling strip with:
  - Name of electronic module
  - Order number
  - Serial number
  - Hardware version number
  - 2D code
- ▶ 3: Labelling strip for the terminal configuration on the base module
- ▶ 4: Name of electronic module
- ▶ 5: Connection level 1
- ▶ 6: Connection level 2
- ▶ 7: Connection level 3
- ▶ 8: Connection level 4

- ▶ 9: Square mounting holes (connection levels 1, 2, 3 and 4)
  - With screw to loosen/tighten the screw terminal on base modules with screw terminals
  - With mechanism to operate the cage clamp on base modules with cage clamp terminals
- ▶ 10: Round connection holes (connection levels 1, 2, 3 and 4) for connecting the signal lines
- ▶ 11: Mounting slot for colour marker to label the connection level (connection levels 1, 2, 3 and 4)



## 3 Safety

### 3.1 Intended use

The module may be used to convert a 24 V protective extra low voltage, in order to supply sensors and actuators connected to the PSSuniversal system.

Intended use includes making the electrical installation EMC-compliant. Please refer to the guidelines stated in the "PSSuniversal Installation Manual". The module is designed for use in an industrial environment. It is not suitable for use in a domestic environment, as this can lead to interference.

The following is deemed improper use in particular:

- ▶ Any component, technical or electrical modification to the module
- ▶ Use of the module outside the areas described in this manual
- ▶ Any use of the module that is not in accordance with the technical details.



#### INFORMATION

The module is supported by

- ▶ PSSuniversal Configurator and PSSuniversal Assistant from Version 1.5.0
- ▶ PAS4000 from Version 1.1.1
  - We recommend that you always use the latest version (download from [www.pilz.de](http://www.pilz.de)).

The PSSu E PS-P 5V module may be used in conjunction with the following base modules:

- ▶ PSSu BP 1/8 S
- ▶ PSSu BP 1/8 C
- ▶ PSSu BP 1/12 S
- ▶ PSSu BP 1/12 C
- ▶ PSSu BP-C1 1/12 S
- ▶ PSSu BP-C1 1/12 C

## **3.2 Safety regulations**

### **3.2.1 Use of qualified personnel**

The products may only be assembled, installed, programmed, commissioned, operated, maintained and decommissioned by persons who are competent to do so.

A competent person is a qualified and knowledgeable person who, because of their training, experience and current professional activity, has the specialist knowledge required. To be able to inspect, assess and operate devices, systems and machines, the person has to be informed of the state of the art and the applicable national, European and international laws, directives and standards.

It is the company's responsibility only to employ personnel who

- ▶ Are familiar with the basic regulations concerning health and safety / accident prevention,
- ▶ Have read and understood the information provided in the section entitled Safety
- ▶ Have a good knowledge of the generic and specialist standards applicable to the specific application.

### **3.2.2 Warranty and liability**

All claims to warranty and liability will be rendered invalid if

- ▶ The product was used contrary to the purpose for which it is intended,
- ▶ Damage can be attributed to not having followed the guidelines in the manual,
- ▶ Operating personnel are not suitably qualified,
- ▶ Any type of modification has been made (e.g. exchanging components on the PCB boards, soldering work etc.).

### **3.2.3 Disposal**

- ▶ In safety-related applications, please comply with the mission time  $T_M$  in the safety-related characteristic data.
- ▶ When decommissioning, please comply with local regulations regarding the disposal of electronic devices (e.g. Electrical and Electronic Equipment Act).

## 4 Function description

### 4.1 Block diagram

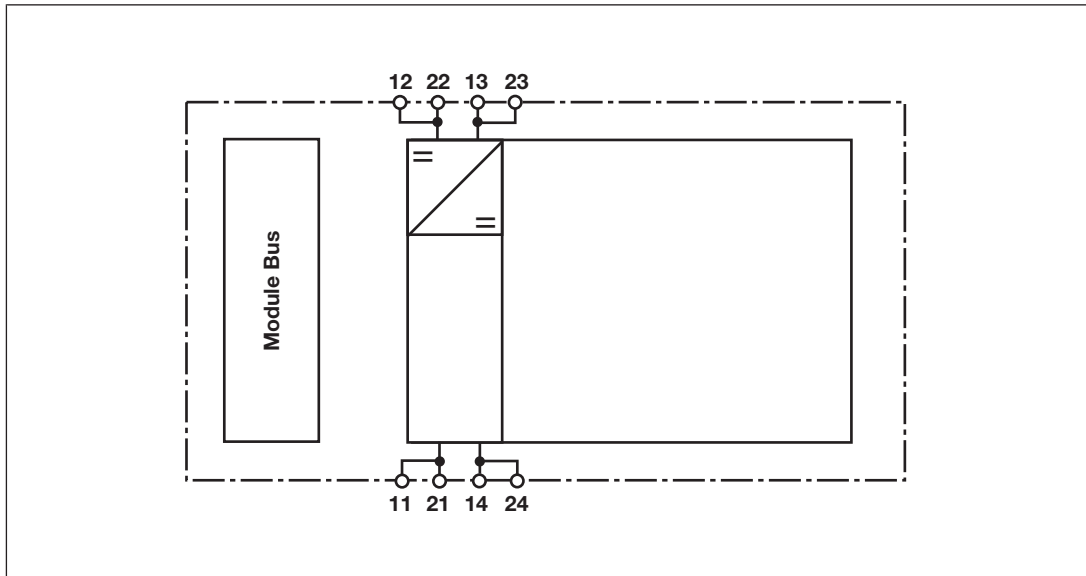

### 4.2 Module features

#### 4.2.1 Integrated protection mechanisms

The module has the following protection mechanisms:

- ▶ Short circuit-proof
- ▶ Temperature monitoring
  - Shutdown in the case of overload
  - Restart when the module has cooled down.
- ▶ The external supply and the module bus supplies are galvanically isolated.

#### 4.2.2 Functions

The modules are typically used to supply periphery devices, such as:

- ▶ Encoder
- ▶ Pressure gauges
- ▶ Transducers
- ▶ Potentiometer

Module supply

- ▶ The module needs no supply from the module supply.
- ▶ The module distributes the module supply on the module bus.

Periphery supply

- ▶ The module needs no supply from the periphery supply.
- ▶ The periphery supply is not available on the module's connection terminals.

- ▶ The module distributes the periphery supply on the module bus.

#### External supplies

- ▶ The module provides connections for external supplies. The external supplies are fed to the base module terminals.
- ▶ Please refer to the derating diagram.
- ▶ Primary side of power supply
  - Voltage: 24 V
  - Max. power consumption: 12 W
- ▶ Secondary side of power supply
  - The module supplies the output voltage to the base module terminals.
  - No buffer when the supply voltage is interrupted
  - Voltage: 5 V
  - Max. continuous output: 10 W
  - Max. current at 5 V: 2 A

## 4.3 Configuration

The module does not have to be configured.

## 5 Installation

### 5.1 General installation guidelines

Please also refer to the PSSuniversal Installation Manual.



#### NOTICE

Damage due to electrostatic discharge!

Electrostatic discharge can damage components. Ensure against discharge before touching the product, e.g. by touching an earthed, conductive surface or by wearing an earthed armband.

#### 5.1.1 Dimensions

Base modules with four connection levels:

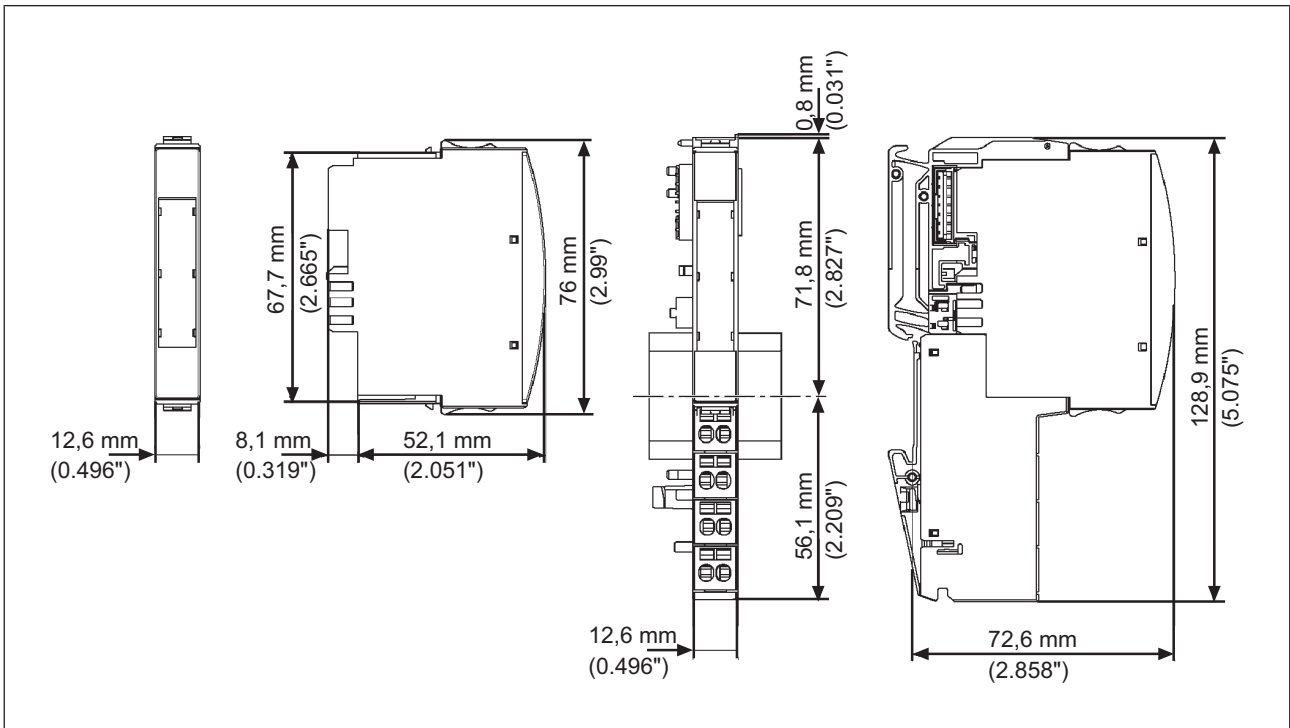

Base modules with six connection levels:

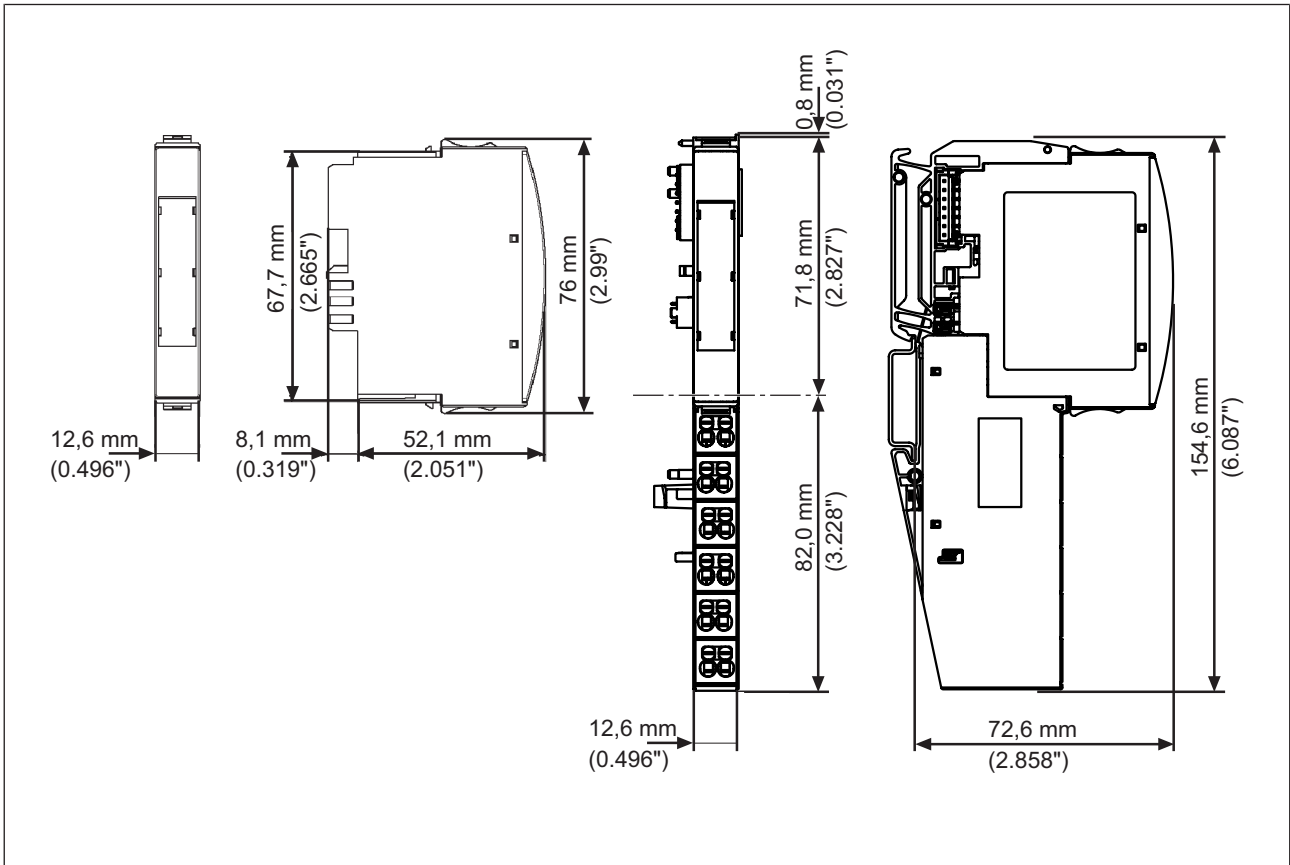

## 5.2 Installing the base module

Prerequisite:

- ▶ The head module must be installed.
- ▶ If the head module does not have an integrated power supply, a supply voltage module must be installed to the right of the head module.

Please note:

- ▶ For mechanical reasons it is not possible to mix base modules with screw terminals and base modules with cage clamp terminals.
- ▶ All contacts should be protected from contamination.
- ▶ The mechanics of the base modules are designed for 50 plug in/out cycles.

Procedure:

- ▶ We recommend that you wire up the base modules before inserting the electronic modules.
- ▶ Slot the groove on the base module on to the mounting rail from below [1].
- ▶ Push the base module back [2] until you hear it lock into position.
- ▶ On the mounting rail, slide the base module to the left until you hear the two lateral mounting hooks on the adjacent module lock into position [3].

Schematic representation:

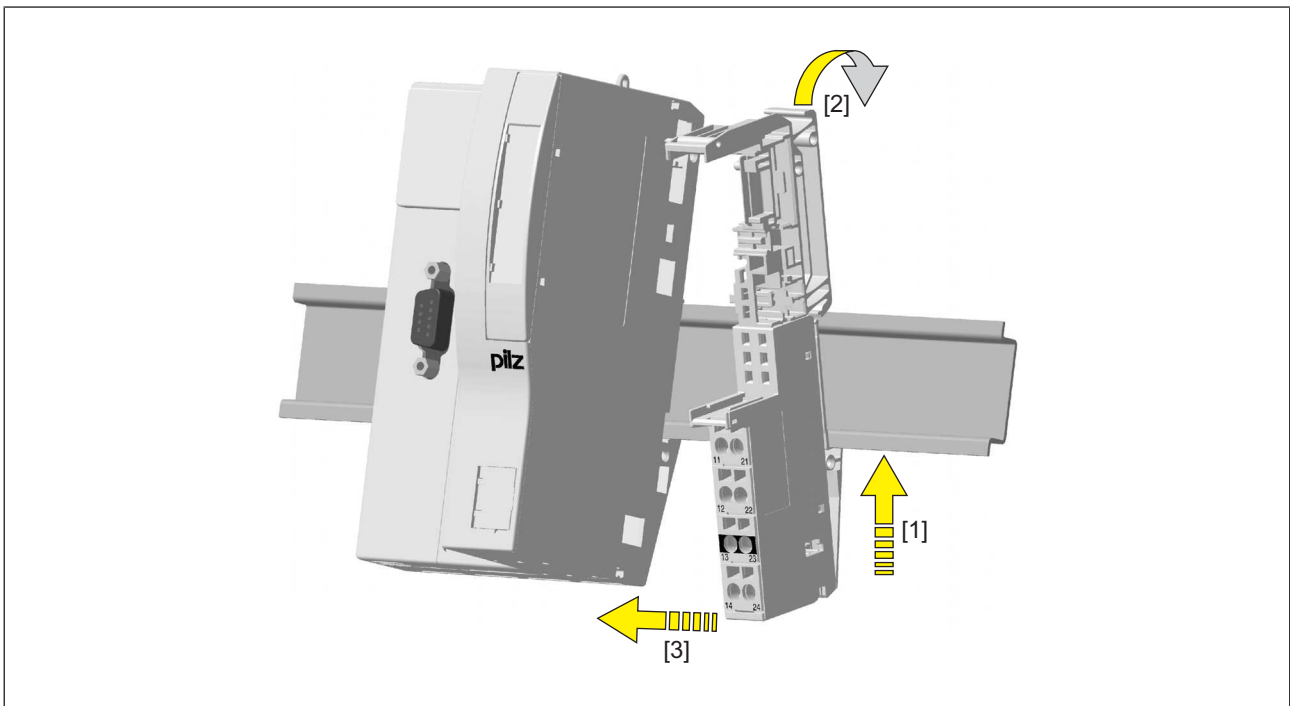

## 5.3 Inserting and removing an electronic module

Please note:

- ▶ Only insert on to base modules that are already installed.
- ▶ Preferably these base modules should be ready wired.
- ▶ Electronic modules with outputs may only be inserted and removed when the load is switched off. Unforeseeable error reactions may be triggered if modules are inserted and removed under load.
- ▶ When an electronic module is plugged into a base module for the first time, one part of the coding element remains on the electronic module, while its counterpart is fixed on to the base module. This is how the base module is coded.
- ▶ The mechanics of the electronic modules are designed for 50 plug in/out cycles.



### 5.3.1 Inserting an electronic module

Procedure:

- ▶ The electronic module must audibly lock into position [1].
- ▶ Mark the electronic module using the labelling strips [2].

Schematic representation:

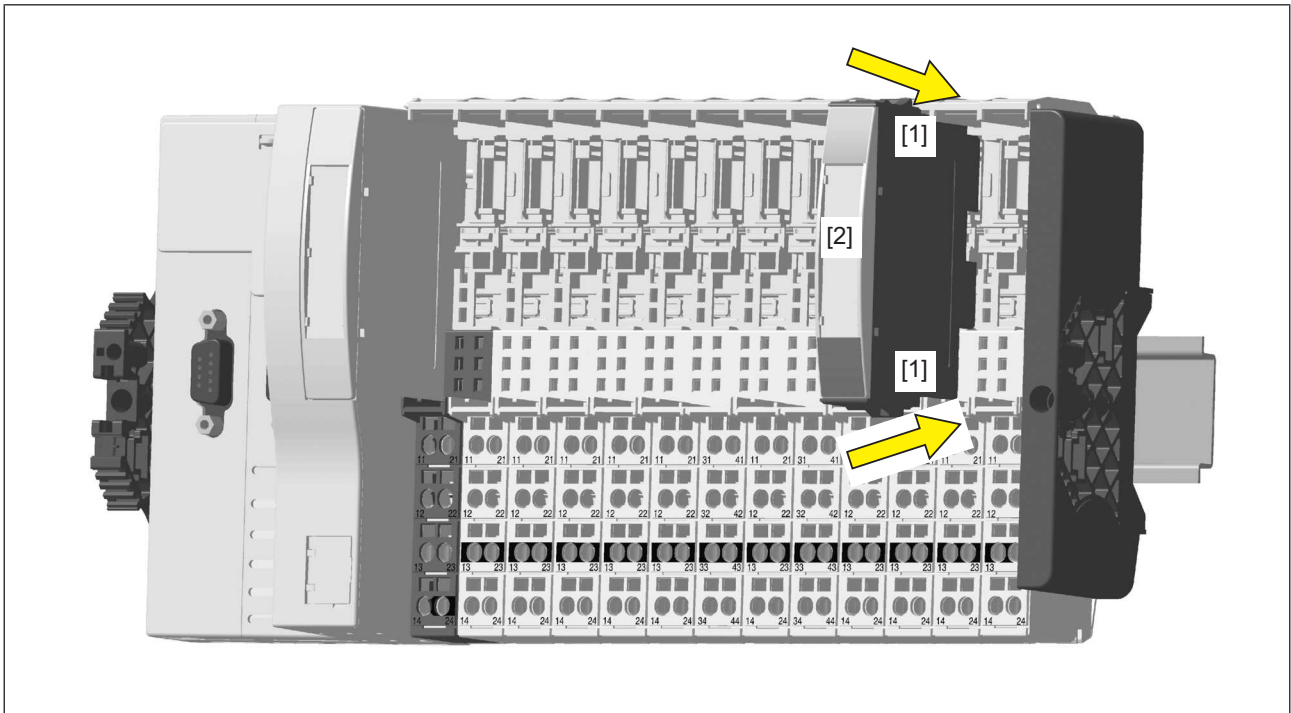

### 5.3.2 Removing an electronic module

Procedure:

- ▶ Press the locking mechanisms [1] together simultaneously.
- ▶ Pull out the electronic module [2].

Schematic representation:

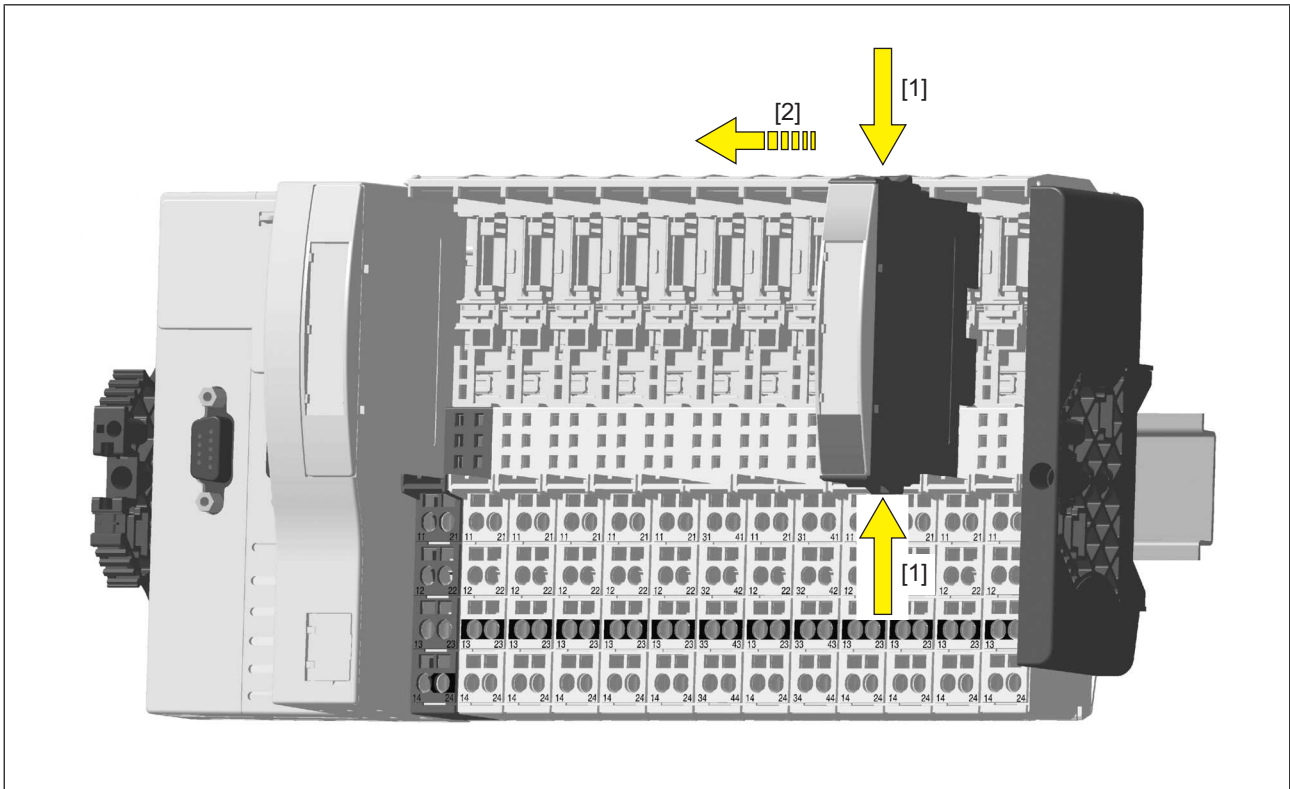

### 5.3.3 Changing an electronic module during operation

It is possible to change an electronic module during operation. The configuration data is retained when a module is changed.

Effects:

- ▶ System environment A:
  - In the event of a potential FS communication error, the FS section of the PSSu system and all relevant I/O-Groups (SafetyBUS p) switch to a STOP condition.
- ▶ System environment B:
  - All FS hardware outputs on the PSSu system switch to a safe condition.
  - The substitute values are used for the modules' FS outputs, with Valid Bits = FALSE.



#### CAUTION!

Sparking can cause interference and errors!

Only change the module when the load is switched off!

## 6 Wiring

### 6.1 General wiring guidelines

Please note:

- ▶ Safe electrical isolation must be ensured for the external supplies. Failure to do so could result in electric shock.
- ▶ Use copper wiring.
- ▶ The terminal configuration as stated on the front plate applies for base modules with C-rail. The terminal configuration as stated in the technical documentation applies for all other base modules.

#### 6.1.1 Mechanical connection of the base modules

Procedure:

- ▶ Use a flat blade screwdriver (DIN 5264-A)!

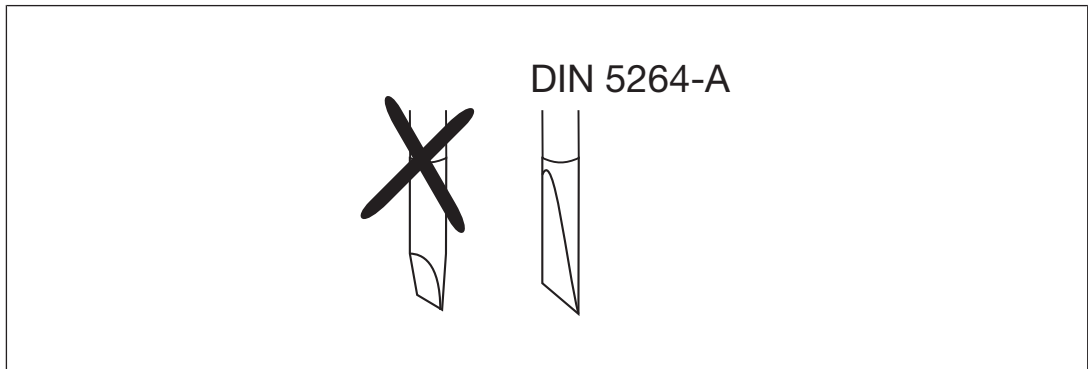

- ▶ Strip the wire back 8 mm.
- ▶ If necessary, label the connection level with a colour marker [3].
- ▶ Base module with screw terminals:
  - Use a screwdriver to loosen the screw on the screw terminal [1]
  - Insert the stripped cable into the round fixing hole [2], as far as it will go.
  - Tighten up the screw on the screw terminal.
  - Check that the cable is firmly seated.
- ▶ Base module with cage clamp terminals:
  - Insert the screwdriver [4] into the square hole [1].
  - Insert the stripped cable into the round fixing hole [2], as far as it will go [5].
  - Pull out the screwdriver [6].
  - Check that the cable is firmly seated.

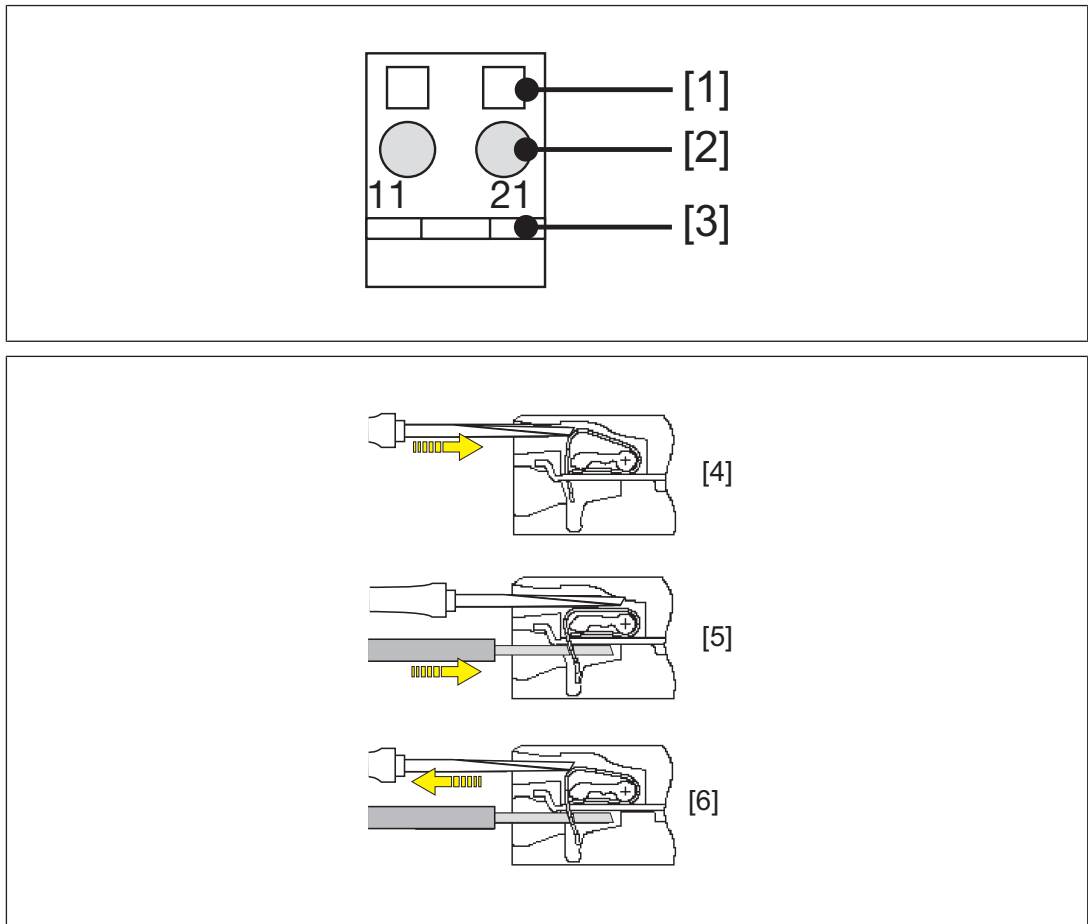

Please note:

- ▶ The minimum cable cross section for field connection terminals on the base modules is 0.14 mm<sup>2</sup> (AWG26).
- ▶ The maximum cable cross section for field connection terminals is:
  - Digital inputs: 1.5 mm<sup>2</sup> (AWG16)
  - Digital outputs: 2.0 mm<sup>2</sup> (AWG14)
  - Inputs/outputs on the counter modules: 1.5 mm<sup>2</sup> (AWG16)
  - Analogue inputs/outputs: 1.5 mm<sup>2</sup> (AWG16)
  - Communication cables: 1.5 mm<sup>2</sup> (AWG16)
  - Test pulse outputs: 1.5 mm<sup>2</sup> (AWG16)
  - Power supply: 2.5 mm<sup>2</sup> (AWG12)
  - Functional earth: 2.5 mm<sup>2</sup> (AWG12)
- ▶ On base modules with screw terminals:
  - If you use a multi-strand cable to connect the I/Os, it is recommended that you use ferrules conforming to Parts 1 and 2 of DIN 46228, 0.14 ... 1.5 mm<sup>2</sup>, Form A or C, although this is not essential. To crimp the ferrules you can use crimp pliers (crimp form A or C) conforming to EN 60947-1, such as the PZ 1.5 or PZ 6.5 from Weidmüller, for example.
  - Maximum torque setting: 0.8 Nm

► Use copper wiring.

## 6.2 Terminal configuration

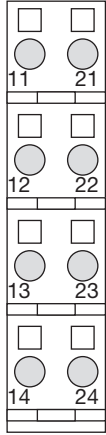
Base module	Terminal configuration	
<p>Screw terminals: PSSu BP 1/8 S PSSu BP 1/8 S-T</p> <p>Cage clamp terminals: PSSu BP 1/8 C PSSu BP 1/8 C-T</p>	<p>Without C-rail:</p> <p>11 -21: 0 V extraction (11-21 linked internally)</p> <p>12 -22: 0 V infeed (12-22 linked within the base module)</p> <p>13 -23: +24 V infeed (13-23 linked within the base module)</p> <p>14 -24: +5 V extraction (14-24 linked internally)</p>	

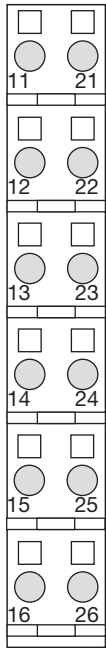
Base module	Terminal configuration	
<p>Screw terminals: PSSu BP 1/12 S PSSu BP 1/12 S-T</p> <p>Cage clamp terminals: PSSu BP 1/12 C PSSu BP 1/12 C-T</p>	<p>Without C-rail:</p> <p>11 -21: 0 V extraction (11-21 linked internally)</p> <p>12 -22: 0 V infeed (12-22-15-25 linked within the base module)</p> <p>13 -23: +24 V infeed (13-23-16-26 linked within the base module)</p> <p>14 -24: +5 V extraction (14-24 linked internally)</p> <p>15 -25: 0 V infeed (12-22-15-25 linked within the base module)</p> <p>16 -26: +24 V infeed (13-23-16-26 linked within the base module)</p>	

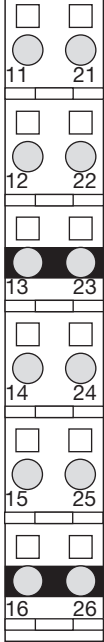
Base module	Terminal configuration	
<p>Screw terminals:  PSSu BP-C1 1/12 S  PSSu BP-C1 1/12 S-T</p> <p>Cage clamp terminals:  PSSu BP-C 1/12 C  PSSu BP-C 1/12 C-T</p>	<p>With C-rail:</p> <p>11 -21: 0 V extraction  (11-21 linked internally)</p> <p>12 -22: 0 V infeed  (12-22 linked within the base module)</p> <p>13 -23: C-rail supply  (13-23-16-26 linked within the base module)</p> <p>14-24: +5 V extraction  (14-24 linked internally)</p> <p>15-25: +24 V infeed  (15-25 linked within the base module)</p> <p>16-26: C-rail supply  (13-23-16-26 linked within the base module)</p>	



## 7 Operation

### 7.1 Messages

The module provides no diagnostic data.



### 7.2 Display elements

#### Legend

-  LED on
-  LED off

#### 7.2.1 Display elements for module diagnostics

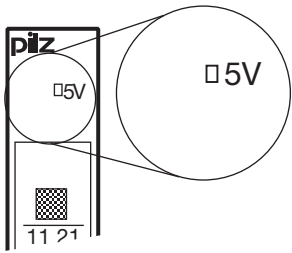
A status LED is assigned to the power supply's output voltage ("5 V" LED).

	LED			Key
	Description	Colour	Status	
	5 V	---		No output voltage or error in the output voltage
	green		Output voltage is error-free	



## 8 Technical details

<b>General</b>	
Certifications	<b>BG, CE, TÜV, UKCA, cULus Listed</b>
Application range	<b>Standard</b>
Application in system environment A	
From FS firmware version, other head modules	<b>1</b>
From ST firmware version, other head modules	<b>1</b>
From FS firmware version PSSu H F PN	<b>1</b>
From ST firmware version PSSu H S PN	<b>1</b>
From ST firmware version PSSu WR S IDN	<b>1</b>
Application in system environment B	
From FS firmware version, head modules	<b>1.0.0</b>
From ST firmware version, head modules	<b>1.0.0</b>
<b>Electrical data</b>	
Supply voltage	
for	<b>Input</b>
Voltage	<b>24 V</b>
Kind	<b>DC</b>
Voltage tolerance	<b>-30 %/+25 %</b>
Output of external power supply (DC)	<b>12 W</b>
Secondary side (output voltage)	
Voltage tolerance	<b>-2 %/+2 %</b>
Output voltage	<b>5 V</b>
Max. current	<b>2 A</b>
Output power	<b>10 W</b>
Max. power dissipation of module	<b>1,5 W</b>
<b>Environmental data</b>	
Climatic suitability	<b>EN 60068-2-1, EN 60068-2-14, EN 60068-2-2, EN 60068-2-30, EN 60068-2-78</b>
Ambient temperature	
In accordance with the standard	<b>EN 60068-2-14</b>
Temperature range	<b>0 - 60 °C</b>
Storage temperature	
In accordance with the standard	<b>EN 60068-2-1/-2</b>
Temperature range	<b>-25 - 70 °C</b>
Climatic suitability	
In accordance with the standard	<b>EN 60068-2-30, EN 60068-2-78</b>
Humidity	<b>93 % r. h. at 40 °C</b>
Condensation during operation	<b>Not permitted</b>
Max. operating height above sea level	<b>2000 m</b>
EMC	<b>EN 61000-4-2, EN 61000-4-3, EN 61000-4-4, EN 61000-4-5, EN 61000-4-6, EN 61000-6-2, EN 61000-6-4</b>

### Environmental data

#### Vibration

In accordance with the standard	<b>EN 60068-2-6</b>
Frequency	<b>10 - 55 Hz</b>
Amplitude	<b>0,35 mm</b>
Acceleration	<b>1g</b>

#### Shock stress

In accordance with the standard	<b>EN 60068-2-27</b>
Number of shocks	<b>6</b>
Acceleration	<b>15g</b>
Duration	<b>11 ms</b>
In accordance with the standard	<b>EN 60068-2-27</b>
Number of shocks	<b>1000</b>
Acceleration	<b>10g</b>
Duration	<b>16 ms</b>

#### Airgap creepage

Overvoltage category	<b>II</b>
Pollution degree	<b>2</b>

#### Protection type

In accordance with the standard	<b>EN 60529</b>
Mounting area (e.g. control cabinet)	<b>IP54</b>
Housing	<b>IP20</b>
Terminals	<b>IP20</b>

### Mechanical data

#### Material

Bottom	<b>PC</b>
Front	<b>PC</b>
Coding	<b>PA</b>

#### Mounting type

**plug-in**

#### Dimensions

Height	<b>76 mm</b>
Width	<b>12,6 mm</b>
Depth	<b>60,2 mm</b>

#### Weight

**34 g**

#### Mechanical coding

Type	<b>B</b>
Colour	<b>Light grey</b>

Where standards are undated, the 2015-03 latest editions shall apply.

## 9 Order reference

### 9.1 Product

Product type	Features	Order No.
PSSu E PS-P 5V	Electronic module, base type	312 590

### 9.2 Accessories

#### Base modules

Product type	Features	Order No.
PSSu BP 1/8 S	Base module without C-rail with screw terminals	312 600
PSSu BP 1/8 C	Base module without C-rail with cage clamp terminals	312 601
PSSu BP 1/12 S	Base module without C-rail with screw terminals	312 618
PSSu BP 1/12 C	Base module without C-rail with cage clamp terminals	312 619
PSSu BP-C1 1/12 S	Base module with C-rail and screw terminals	312 622
PSSu BP-C1 1/12 C	Base module with C-rail and cage clamp terminals	312 623

